

UNITED STATES
SECURITIES AND EXCHANGE COMMISSION
Washington, D.C. 20549

FORM 10-K

ANNUAL REPORT PURSUANT TO SECTION 13 OR 15(d) OF THE SECURITIES
EXCHANGE ACT OF 1934

For the fiscal year ended December 31, 2014

OR

TRANSITION REPORT PURSUANT TO SECTION 13 OR 15(d) OF THE EXCHANGE ACT

Commission file number: 000-53704

AMP HOLDING INC.

(Name of registrant as specified in its charter)

Nevada

(State or other jurisdiction of incorporation or organization)

26-1394771

(I.R.S. Employer Identification No.)

100 Commerce Drive

Loveland, Ohio 45140

(Address of principal executive offices)

513-360-4704

(Registrant's telephone number)

SECURITIES REGISTERED PURSUANT TO SECTION 12(b) OF THE EXCHANGE ACT:

None

SECURITIES REGISTERED PURSUANT TO SECTION 12(g) OF THE EXCHANGE ACT:

Common Stock, \$0.001 par value per share

Indicate by check mark if the Registrant is a well-known seasoned issuer, as defined in Rule 405 of the Securities Act. Yes No

Indicate by check mark if the Registrant is not required to file reports pursuant to Section 13 or Section 15(d) of the Act. Yes No

Indicate by check mark whether the Registrant (1) has filed all reports required to be filed by Section 13 or 15(d) of the Securities Exchange Act of 1934 during the preceding 12 months (or for such shorter period that the Registrant was required to file such reports), and (2) has been subject to such filing requirements for the past 90 days. Yes No

Indicate by check mark whether the registrant has submitted electronically and posted on its corporate Web site, if any, every Interactive Data File required to be submitted and posted pursuant to Rule 405 of Regulation S-T during the preceding 12 months (or for such shorter period that the registrant was required to submit and post such files). Yes No

Indicate by check mark if disclosure of delinquent filers pursuant to Item 405 of Regulation S-K (§229.405 of this chapter) is not contained herein, and will not be contained, to the best of Registrant's knowledge, in definitive proxy or information statements incorporated by reference in Part III of this Form 10-K or any amendment to this Form 10-K.

Indicate by check mark whether the registrant is a large accelerated filer, an accelerated filer, a non-accelerated filer, or a smaller reporting company. See the definitions of "large accelerated filer", "accelerated filer" and "smaller reporting company" in Rule 12b-2 of the Exchange Act.

Large accelerated filer

Non-accelerated filer

Accelerated filer

Smaller reporting company

Indicate by check mark whether the registrant is a shell company (as defined in Rule 12b-2 of the Exchange Act). Yes No

As of June 30, 2014, the last business day of the Registrant's most recently completed second fiscal quarter, the market value of our common stock held by non-affiliates was \$8,211,540.

The number of shares of the Registrant's common stock, \$0.001 par value per share, outstanding as of March 27, 2015, was 150,242,334.

TABLE OF CONTENTS

PART I

Item 1.	Business	4
Item 1A.	Risk Factors	11
Item 1B.	Unresolved Staff Comments	17
Item 2.	Properties	18
Item 3.	Legal Proceedings	18
Item 4.	Mine Safety Disclosures	18

PART II

Item 5.	Market for Registrant's Common Equity, Related Stockholder Matters and Issuer Purchases of Equity Securities	18
Item 6.	Selected Financial Data	24
Item 7.	Management's Discussion and Analysis of Financial Condition and Results of Operations	24
Item 7A.	Quantitative and Qualitative Disclosures About Market Risk	28
Item 8.	Financial Statements and Supplementary Data	F-1
Item 9.	Changes in and Disagreements with Accountants on Accounting and Financial Disclosure	29
Item 9A.	Controls and Procedures	29
Item 9B.	Other Information	29

PART III

Item 10.	Directors, Executive Officers and Corporate Governance	30
Item 11.	Executive Compensation	32
Item 12.	Security Ownership of Certain Beneficial Owners and Management and Related Stockholder Matters	35
Item 13.	Certain Relationships and Related Transactions, and Director Independence	36
Item 14.	Principal Accounting Fees and Services	36

PART IV

Item 15.	Exhibits, Financial Statement Schedules	37
	Signatures	39

Forward-Looking Statements

The discussions in this Annual Report contain forward-looking statements reflecting our current expectations that involve risks and uncertainties. When used in this Report, the words “anticipate”, “expect”, “plan”, “believe”, “seek”, “estimate” and similar expressions are intended to identify forward-looking statements. These are statements that relate to future periods and include, but are not limited to, statements about the features, benefits and performance of our products, our ability to introduce new product offerings and increase revenue from existing products, expected expenses including those related to selling and marketing, product development and general and administrative, our beliefs regarding the health and growth of the market for our products, anticipated increase in our customer base, expansion of our products functionalities, expected revenue levels and sources of revenue, expected impact, if any, of legal proceedings, the adequacy of liquidity and capital resource, and expected growth in business. Forward-looking statements are subject to risks and uncertainties that could cause actual results to differ materially from those projected. These risks and uncertainties include, but are not limited to, market acceptance for our products, our ability to attract and retain customers for existing and new products, our ability to control our expenses, our ability to recruit and retain employees, legislation and government regulation, shifts in technology, global and local business conditions, our ability to effectively maintain and update our product and service portfolio, the strength of competitive offerings, the prices being charged by those competitors and the risks discussed elsewhere herein. These forward-looking statements speak only as of the date hereof. We expressly disclaim any obligation or undertaking to release publicly any updates or revisions to any forward-looking statements contained herein to reflect any change in our expectations with regard thereto or any change in events, conditions or circumstances on which any such statement is based.

All references in this Form 10-K that refer to the “Company”, “AMP Holding”, “AMP”, “we,” “us” or “our” are to AMP Holding Inc. and unless otherwise differentiated, its wholly-owned subsidiaries, AMP Electric Vehicles Inc. and AMP Trucks Inc.

PART I

ITEM 1. BUSINESS

Overview

We design, develop, manufacture, and sell high-performance, medium-duty trucks with advanced powertrain components under the Workhorse proven chassis brand. We believe that our vehicles, engineering expertise, innovation, and operational structure differentiate us from traditional truck manufacturers.

We recently announced that we filed a provisional patent for a new system that extends the range of electric vehicles while reducing the overall cost of the typical battery-electric power train. The new system, E-GEN Drive(TM), is designed specifically for the package delivery vehicle market, in which the diesel and/or gasoline-powered vehicles in use now, stop and restart hundreds of times a day. We believe that battery-electric technology is an ideal fit for urban and suburban delivery routes and we understand fleet owner's concerns about range anxiety and cost. Our E-GEN Drive system will enable them to keep the batteries recharged to a consistent state of charge throughout the day and, since we are able to use smaller battery packs, we can reduce the cost of the entire system. Our E-GEN Drive trucks, offer a three-year payback making them price competitive with gasoline-powered trucks.

Our association with Power Solutions International (PSIX:NASDAQ) provides us with multi-fuel engines that function as generators. When the ignition is shut off, the engine automatically turns on and recharges the battery pack. When the ignition is turned back on, the engine turns off and the vehicle reverts to all-electric power. The engine and the battery-powered motor are never in use at the same time. It's not a traditional hybrid, but an extended-range electric vehicle.

As a result, we believe our new design has many benefits, including:

- Fleet management flexibility: Depending on our customer's driving patterns and fuel cost goals, our E-GEN drive train can be remotely adjusted to use more electric power or internal combustion engine (ICE) power at their choice.
- Energy efficiency and cost of ownership: We believe our trucks offer our customers an attractive cost of ownership profile when compared to similar products. Using a single electric powertrain with a small ICE enables us to create a lighter, more energy efficient vehicle that is mechanically simple. Since we are able to use smaller battery packs, we can reduce the cost of the entire system. Additionally, government incentives can reduce the cost of ownership even further.
- High performance: We believe our trucks deliver an unparalleled driving experience with powerful acceleration for the most demanding applications with the added benefit of a very quiet operation.

We also announced the second generation, full-electric truck "E-100" which is a significant improvement to our first generation vehicle. The second-generation vehicle includes a single powerful electric motor with no transmission and new lighter, high-density Lithium Ion batteries giving the vehicle a range of up to 100 miles.

In March of 2013, we purchased the former Workhorse Custom Chassis assembly plant in Union City, Indiana from Navistar International (NAV:NYSE). With this acquisition, we became an Original Equipment Manufacturer (OEM) of Class 3-6 commercial-grade, medium-duty truck chassis to be marketed under the Workhorse® brand.

Ownership and operation of this plant enables us to build new chassis with gross vehicle weight capacities of between 10,000 and 26,000 pounds and offer them in four different fuel variants—electric, gas, propane, and compressed natural gas (CNG). We plan to offer commonly known Workhorse chassis like the W22, W42, W62, as well as a new, 88" track, W88 truck chassis that will be offered to fleet purchasing managers at price points that are both attractive and cost competitive.

At the same time, AMP intends to partner with engine suppliers and body fabricators to offer fleet-specific, custom, purpose-built chassis that provide total cost of ownership solutions that are superior to the competition.

In addition to having the ability to build our own chassis, we design and produce battery-electric power trains that can be installed in new Workhorse chassis or installed as repower packages to convert used Class 3-6 medium-duty vehicles from diesel or gasoline power to electric power. Our approach is to provide battery-electric power trains utilizing proven, automotive-grade, mass-produced parts in its architecture coupled with in-house control software that we have developed over the last five years.

The Workhorse Custom Chassis acquisition includes other important assets including the Workhorse brand and logo, intellectual property, schematics, logistical support from Up-Time Parts (a Navistar subsidiary) and, perhaps most importantly, a network of 400-plus sales and service outlets across North America. We believe combination of AMP's chassis assembly capability, coupled with its ability to offer an array of fuel choices, gives AMP/Workhorse a unique opportunity in the marketplace.

AMP is also engineering the future of parcel delivery aviation: HorseFly™, an Unmanned Aerial Vehicle (UAV) that is designed for the package delivery market as well as other commercial applications. Our UAV works in tandem with our electric truck to bring a practical low cost solution make the last mile more efficient and cost effective for our parcel customers.

Our Products

Trucks:

Powertrain:

E-GEN

In January of 2014, AMP Holdings Inc. submitted a patent application for a new drive system. This revolutionary design is an extended range electric drive system that we call the E-GEN. This system is an electric drive that has a gasoline/propane or CNG engine that functions as an auxiliary generator that only runs when the battery reaches a certain level of depletion, the vehicle is in PARK and the key is out. This system combines battery-electric propulsion with a low-horsepower, fossil fuel generator to produce a vehicle that gets two to four times the miles per gallon of its conventional counterpart, thus providing the fleet operator with a solution that has a three-year payback without any government incentives. We believe that this is the ideal solution for the domestic package delivery fleet operators as well as other specialized markets (i.e. shuttle, school, public transportation buses, and specialty-use vehicles). We are currently working with the California Air Resource Board (CARB) and the Environmental Protection Agency (EPA) to get approval for this design so it can qualify for governmental incentives.

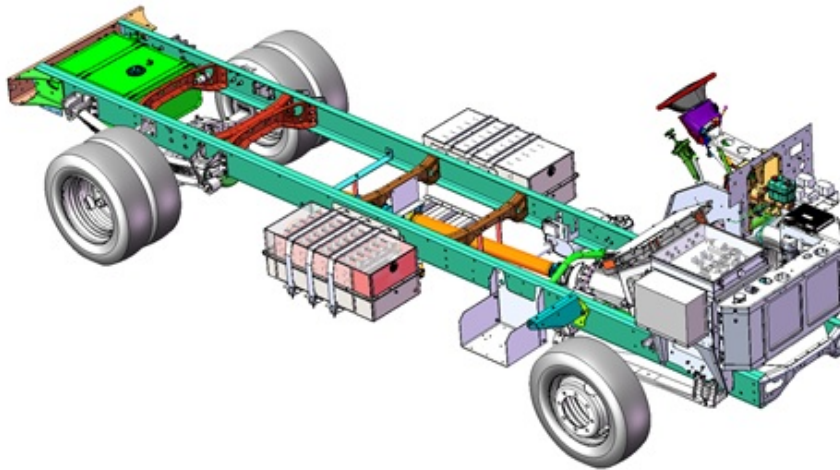

Our approach to the commercial market is to provide alternative-fueled chassis at competitive prices that are as reliable and consistent, in all aspects, as the Navistar chassis that last rolled off the line in the last quarter of 2012. Our sales strategy targets the Top Fleet Buyers. We have restored purchasing arrangements with key parts suppliers, forged an arrangement for logistics support with UpTime Parts, Inc. and structured an engine supply agreement with Power Solutions International (NASDAQ:PSIX).

We are focused on the extended range electric E-GEN solution since it offers the customer a solution that provides answers to their key concerns with electric vehicles (i.e. range issues in cold weather, peak season requirements, infrastructure costs, and “what are my options if there is a power outage?”).

E-100

Our AMP E-100 all-electric, medium-duty truck is the second generation full electric power-train that is a significant improvement to our first generation. It includes a single electric motor with no transmission and new lighter, high-density Lithium Ion batteries giving it a range of up to 100 miles. This application has received California Air Resources Board approval for sale in California and is now on the California HVIP list and eligible for incentive purchase. Additionally, we are also approved in New York under the NYSERDA Program and approved for both new trucks and repowers under the Drive Clean Chicago incentive program.

Chassis:

W88

The new W88 chassis is designed to meet the needs of a wide range of customers. At the same time, it is a universal chassis from an operations perspective. We believe that this chassis will be the workhorse of our product offerings. We expect to offer this chassis with gross vehicle weight GVW ratings of 10,000 to 26,000 pounds. It will also be offered with drive train and fuel systems ranging from all-electric, extended range electric EREV utilizing gasoline, propane or CNG, PSI gasoline 6-liter engine, propane, and CNG.

W22

The W22 chassis is designed to meet the needs of the recreational vehicle market for weight ratings up to 26,000 GVW. It has been in the marketplace for over 10 years and is well-proven for this application. We will offer this chassis with the PSI 8.8 Liter engine.

W42

The W42 chassis is designed for the 12,000 to 14,500 GVW vehicle market. Like the W22 it has been in the marketplace for over 10 years

and is well-regarded.

W62

The W42 chassis is designed for the 19,500 to 23,500 GVW vehicle market. Like the W22 and W42 it has been in the marketplace for over 10 years and is also well-proven.

Applications:

Commercial Step Vans

Package Delivery Industry: Approximately 80% of the vehicles in this segment operate on a fixed route and travel fewer than 100 miles per day, stop more than 100 times within an average duty cycle of eight to ten hours, and return to an indoor distribution center. The best examples include: UPS, FEDEX, FEDEX Ground, DHL, and Purolator.

Product Delivery Industry: Approximately 70% of the vehicles in this segment operate on a fixed route and travel fewer than 100 miles per day, stop between 50 and 100 times within an average duty cycle of eight to ten hours, and return to a distribution center that is either indoors, or the vehicles are stored at the dock, or in an outdoor lot adjacent to the distribution facility. Examples are: Frito-Lay, Pepsi, Coke, Aramark, Bimbo Bakeries, Peapod, and other grocery delivery services.

Laundry and Uniform Service Industry: Approximately 60% of the vehicles in this segment operate on a fixed route and travel approximately 100 miles per day, stop between 30 and 50 times within an average duty cycle of eight to ten hours, and return to a laundry facility where the vehicles are stored outside the facility. Cintas, Aramark, UniFirst, and Diaper Service are examples.

Food Service Industry: Approximately 80% of the vehicles in this segment operate on a fixed route and travel approximately 100 miles per day stopping between 10 and 30 times within an average duty cycle of eight to ten hours. They return to a commissary facility where the vehicles are stored outside the facility and serviced at this common facility. Food trucks fall into this category.

Utility Industry: The route that these vehicles follow is dependent on the utility and the energy company's territory. Some utilities, for example, are captive to a county or surrounding counties of one large metro area. This model is ideal for a segment of the fleet to be all electric utility vehicles. For the utilities that cover the entire state or even multiple states, CNG, or Hybrid CNG/Electric vehicles are required.

Special Use Industry: This segment basically consists of what is not already mentioned. SWAT, Warehouse on Wheels i.e. Snap-on-Tools, HVAC, Plumbers, and other service applications that require a large cube storage vehicle fit into this category.

The current number of commercial step vans in use in the US is approximately 300,000 units. Today between 3% and 4% are replaced with new vehicles every year. A number of the larger fleets that effectively utilize this type of vehicle replace vehicles at a rate closer to 7% per year. We believe that with the proper mix of alternative fuel options combined with purpose-built chassis for specific use in this segment will result in a replacement rate of as much as 10% in the initial transition period and then a 5% to 7% overall rate long term.

Medium Duty Buses

The next segment that we believe will have significant volume potential for us is the medium duty bus (108"H x 95.5 W x 247" to 286" L) Para-Transit, Shuttle and School Buses are part of this segment. We are able to offer alternative fuel solutions, as well as innovative E-GEN EREV solutions combined with the AMP/Workhorse chassis we believe that this market segment has tremendous potential.

Special Use Vehicles

The special use vehicle segment includes emergency vehicles, wreckers, construction equipment, communications equipment and military base application. This segment is similar to Medium-duty buses in terms of volume potential.

Recreational Vehicles

The final segment that we believe will have significant volume potential for us is the Class 5 and 6 RV chassis market. We believe that the right combination of drive system and Workhorse chassis has the potential to capture a significant portion of the market. Currently, RV manufacturers only have one option if they want to purchase a class 5 or 6 gasoline chassis for an RV application.

Unmanned Aerial Vehicles:

HorseFly™ Unmanned Aerial Vehicle (UAV) is designed for the package delivery market as well as other commercial applications



- Designed to meet the anticipated FAA guidelines expected in 2015
- Differentiated from other UAVs as it's designed to work in tandem with a Workhorse electric truck (patent pending)
- Expected to deliver packages, loaded in route by the driver, to remote locations while the driver continues on the main delivery route, saving the fleet operator much of the fuel cost of the most expensive miles
- HorseFly rejoins the truck at its new location once its delivery is completed
- HorseFly can recharge from atop the Workhorse truck
- Superior to other delivery UAV's operating plans, where the package is loaded at the warehouse and must return to the warehouse once the delivery is completed

Partnered with The University of Cincinnati's Department of Aerospace Engineering and Engineering Mechanics to develop HorseFly Our unique HorseFly line of drones is designed to be the 'last mile' solution in delivery logistics. We worked with the University of Cincinnati to develop the HorseFly to meet the rigors of package delivery and to have eight rotors and redundant systems to ensure safety in the air. Today, we estimate that it costs approximately \$1 to move a 20,000-pound diesel-powered truck one mile. While we believe our Workhorse trucks can reduce the standard delivery costs from \$1 to less than \$0.30 cents per mile based on current costs of fuel, we expect that having drones handle the last leg of delivery could further potentially reduce the cost to about \$0.03 for the last mile. The all-weather HorseFly battery-powered drone will carry up to 10 pounds of cargo with a 15-mile range. It is designed to meet the anticipated FAA drone guidelines expected in 2015, of which there is no guarantee, and is differentiated from other drones as it is designed to work in tandem with a Workhorse electric truck. HorseFly will deliver packages, loaded on-route by the truck's driver, to remote locations while the driver continues on the main delivery route. HorseFly will then rejoin the truck at its new location after its delivery is completed, saving the fleet operator much of the time and fuel cost of the last, most expensive, mile. Also while the HorseFly is atop the Workhorse truck, it can quickly charge its batteries from the truck's large battery pack. We believe this implementation is superior to the proposed deployment of other delivery drones wherein the package is loaded at a distant warehouse and the drone must make a round trip flight to the delivery address and back to the warehouse. Other applications for the HorseFly include transmission line inspections and agricultural surveys.

Technology

Batteries Are Key

The battery pack is key to the design, development, and manufacture of advanced electric-vehicle power trains. Where some other EV manufacturers purchase their batteries in a plug-and-play pack, we build our own battery packs. This keeps the intellectual property related to the design and production of the pack in-house and avoids the issues that occur when a battery supplier fails. And it also enables us to pay less for our batteries and pack than do our competitors thus our all-electric truck is less expensive than competitive vehicles. We use the Panasonic or LG Chem 18650 cells and, like Tesla, design the pack around these commodity cells.

In-House Software Development is Essential

Our power trains encompass the complete motor assemblies, computers, and software required for vehicle electrification. We use off-the-shelf, proven components and combine them with our proprietary software.

Innovation is the Future

Additionally, we have developed a cloud-based, remote management system to manage and track the performance of all of the vehicles that we deploy in order to provide a 21st Century solution for fleet managers.

Locations and Facilities

Our company headquarters and R & D facility is located at 100 Commerce Drive, Loveland, Ohio, a Cincinnati suburb. We occupy a 30,000 sq. ft. facility that allows for the manufacture of 1,000 electric power train kits per year. Power trains will be delivered to the Workhorse facility in Indiana or shipped to our dealer network for onsite installation in conversion vehicles.



Workhorse/AMP Trucks, Inc. Location

Our truck assembly facility is located in Union City, Indiana. This facility consists of three buildings with 270,000 square feet of manufacturing and office space on 46 acres.

Workhorse Facility

In March of 2013, we purchased the former Workhorse Custom Chassis assembly plant in Union City, Indiana. With this acquisition, we became an Original Equipment Manufacturer (OEM) of Class 3-6 commercial-grade, medium-duty truck chassis to be marketed under the Workhorse® brand.



Ownership and operation of this plant enables us to build new chassis with gross vehicle weight capacity of between 10,000 and 26,000 pounds and offer them in four different fuel variants—electric, gas, propane, and CNG. We plan to offer well-known Workhorse chassis like the W22, W42, W62, as well as a new, 88” track W88 truck chassis that will be offered to fleet purchasing managers at price points that are both attractive and cost competitive.

At the same time, AMP intends to partner with engine suppliers and body fabricators to offer fleet-specific, custom, purpose-built chassis that provide total cost of ownership solutions that are superior to the competition.

In addition to building our own chassis, we design and produce battery-electric power trains that can be installed in new Workhorse chassis or installed as repower packages to convert used Class 3-6 medium-duty vehicles from diesel or gasoline power to electric power. Our approach is to provide battery-electric power trains utilizes proven, automotive-grade, mass-produced parts in its architecture coupled with in-house control software that it has developed over the last five years.

The Workhorse Custom Chassis acquisition includes other important assets including the Workhorse brand and logo, intellectual property, schematics, logistical support from UpTime Parts (a Navistar subsidiary) and, perhaps most importantly, a network of 400 plus sales and service outlets across North America. We believe the combination of AMP's chassis assembly capability, coupled with its ability to offer an array of fuel choices, gives AMP/Workhorse a unique opportunity in the marketplace.

Marketing

Our sales team is focused on a targeted list of high profile, former purchasers, and current buyers of the Workhorse chassis with the goal of securing purchase orders from these companies. These purchase orders will give us the first look at next year's chassis demand related to electric and extended range electric vehicles.

Our priority is to establish the commercial step van as our core business. We intend to be the best choice for a vehicle in this segment regardless of the fuel type that the customer chooses. Additionally, our sales plan is to meet with the top potential customers and obtain purchase orders for new electric, extended range electric, gasoline, propane, or CNG vehicles for their production vehicle requirements.

The second segment that we are focused on is medium-duty buses. This is based on fact that we completed two 15-passenger para-transit buses for BARTA (Berks County Regional Transit Authority) in Pennsylvania. These buses are equipped with wireless charging and represent a unique solution for a number of applications (i.e. airport hotels, rental car companies and municipal transit authorities). Once we have completed all of the relevant testing on these buses we will work with bus body builders to develop pricing and plan to offer a Workhorse/AMP chassis for sales in late 2016.

Finally, since our competitive advantage in the marketplace is our ability to provide purpose-built solutions to customers that have unique requirements at relatively low-volume, we have submitted proposals to companies for purpose-built vehicle applications.

AMP Trucks will promote the Workhorse brand at select trade shows, conferences and briefings.

Strategic Relationships

Power Solutions International (PSIX:NASDAQ): PSI supplies engines that are certified and calibrated for on-road use by companies such as AMP/Workhorse utilizing gasoline, propane or CNG as a fuel. They have the ability and the resources to provide engines that meet fleet requirements in volumes that are significantly below the volume requirements of companies like Ford or Freightliner for similar specialized powertrain systems.

Morgan Olsen, Utilimaster, TransTech Bus, ECO, and other up-fitters or body fabricators: All of these companies build bodies customized for the needs of their customers and mated to chassis that are available to them from the short list of chassis suppliers. The functionality and configuration the end-user receives in the finished product is limited by the available chassis/powertrain. AMP/Workhorse will work with these organizations to provide chassis that not only best fit the needs of the end user customer but also provide the customer with a competitive advantage in their specific industry or application.

Research and Development

The majority of our research and development is conducted in-house at our facilities near Cincinnati, Ohio. Additionally, we contract with engineering firms to assist with validation and certification requirements as well as specific vehicle integration tasks.

Competitive Companies

The medium-duty commercial vehicle market is highly competitive and we expect it to become even more so in the future as additional companies launch competing vehicle offerings. The medium-duty commercial alternatively fueled vehicle market, however, is less developed and competitive. There are two primary competitors in the medium-duty vehicle segment in the US market: Ford and Freightliner. Neither has disclosed any plans to offer 100% EV or EREV vehicles in this segment. Ford is vertically integrated building a complete vehicle or chassis including Ford engine and transmission. They provide a chassis as a strip-chassis (which is similar to the Workhorse product) or they provide it with a cab. Freightliner provides a chassis as a strip-chassis, which is similar to the Workhorse/AMP Truck chassis.

We believe the most dramatic difference between AMP and the other competitors in the medium duty truck market is our ability to offer customers purpose-built solutions that meet the needs of their unique requirements at a competitive price. While there are many electric car companies from abroad, there are only a few foreign companies that have vehicles in the category of medium-duty trucks.

We believe that the primary competitive factors within the medium-duty commercial vehicle market are:

- the difference in the initial purchase prices of electric vehicles and comparable vehicles powered by internal combustion engines, both including and excluding the impact of government and other subsidies and incentives designed to promote the purchase of electric vehicles;
- the total cost of vehicle ownership over the vehicle's expected life, which includes the initial purchase price and ongoing operational and maintenance costs;
- vehicle quality, performance and safety;
- government regulations and economic incentives promoting fuel efficiency and alternate forms of energy;
- the quality and availability of service for the vehicle, including the availability of replacement parts; and

GOVERNMENT REGULATION

Our electric vehicles are designed to comply with a significant number of governmental regulations and industry standards, some of which are evolving as new technologies are deployed. Government regulations regarding the manufacture, sale and implementation of products and systems similar to our electric vehicles are subject to future change. We cannot predict what impact, if any, such changes may have upon our business. We believe that our vehicles are in conformity with all applicable laws in all relevant jurisdictions.

Emission and fuel economy standards

Government regulation related to climate change is under consideration at the U.S. federal and state levels. The EPA and the National Highway Traffic Safety Administration, or NHTSA, issued a final rule for greenhouse gas emissions and fuel economy requirements for trucks and heavy-duty engines on August 9, 2011, which will have an initial phase in starting with model year 2014 and a final phase in occurring in model year 2017. NHTSA standards for model year 2014 and 2015 will be voluntary, while mandatory standards will first come into effect in 2016.

The rule provides emission standards for CO₂ and fuel consumption standards for three main categories of vehicles: (i) combination tractors, (ii) heavy-duty pickup trucks and vans and (iii) vocational vehicles. We believe that the Workhorse chassis would be considered "vocational vehicles" under the rule. According to the EPA and NHTSA, vocational vehicles consist of a wide variety of truck and bus types, including delivery, refuse, utility, dump, cement, transit bus, shuttle bus, school bus, emergency vehicles, motor homes and tow trucks, and are characterized by a complex build process, with an incomplete chassis often built with an engine and transmission purchased from other manufacturers, then sold to a body manufacturer.

The EPA and NHTSA rule also establishes multiple flexibility and incentive programs for manufacturers of alternatively fueled vehicles, such as the Workhorse E-100 full electric and the E-Gen Electric, including an engine averaging, banking and trading, or ABT, program, a vehicle ABT program and additional credit programs for early adoption of standards or deployment of advanced or innovative technologies. The ABT programs will allow for emission and/or fuel consumption credits to be averaged, banked or traded within defined groupings of the regulatory subcategories. The additional credit programs will allow manufacturers of engines and vehicles to be eligible to generate credits if they demonstrate improvements in excess of the standards established in the rule prior to the model year the standards become effective or if they introduce advanced or innovative technology engines or vehicles.

The Clean Air Act requires that we obtain a Certificate of Conformity issued by the EPA and a California Executive Order issued by CARB with respect to emissions for our vehicles. The Certificate of Conformity is required for vehicles sold in states covered by the Clean Air Act's standards and the Executive Order is required for vehicles sold in states that have sought and received a waiver from the EPA to utilize California standards. The California standards for emissions control for certain regulated pollutants for new vehicles and engines sold in California are set by CARB. States that have adopted the California standards as approved by EPA also recognize the Executive Order for sales of vehicles.

Manufacturers who sell vehicles in states covered by federal requirements under the Clean Air Act without a Certificate of Conformity may be subject to penalties of up to \$37,500 per violation and be required to recall and remedy any vehicles sold with emissions in excess of Clean Air Act standards. In 2013, we received approval from CARB to sell the E-100 in California based on our own emissions tests.

Vehicle safety and testing

The National Traffic and Motor Vehicle Safety Act of 1966, or the Safety Act, regulates motor vehicles and motor vehicle equipment in the United States in two primary ways. First, the Safety Act prohibits the sale in the United States of any new vehicle or equipment that does not conform to applicable motor vehicle safety standards established by NHTSA. Meeting or exceeding many safety standards is costly, in part because the standards tend to conflict with the need to reduce vehicle weight in order to meet emissions and fuel economy standards. Second, the Safety Act requires that defects related to motor vehicle safety be remedied through safety recall campaigns. A manufacturer is obligated to recall vehicles if it determines that the vehicles do not comply with a safety standard. Should we or NHTSA determine that either a safety defect or noncompliance exists with respect to any of our vehicles, the cost of such recall campaigns could be substantial.

Battery safety and testing

Our battery packs conform to mandatory regulations that govern transport of "dangerous goods," which includes lithium-ion batteries, which may present a risk in transportation. The governing regulations, which are issued by PHMSA, are based on the UN Recommendations on the Safe Transport of Dangerous Goods Model Regulations, and related UN Manual of Tests and Criteria. The requirements for shipments of these goods vary by mode of transportation, such as ocean vessel, rail, truck and air.

Our battery module suppliers have completed the applicable transportation tests for our prototype and production battery packs demonstrating our compliance with the UN Manual of Tests and Criteria, including:

- altitude simulation, which involves simulating air transport;
- thermal cycling, which involves assessing cell and battery seal integrity;
- vibration, which involves simulating vibration during transport;
- shock, which involves simulating possible impacts during transport;
- external short circuit, which involves simulating an external short circuit; and
- overcharge, which involves evaluating the ability of a rechargeable battery to withstand overcharging.

Vehicle dealer and distribution regulation

Certain states' laws require motor vehicle manufacturers and dealers to be licensed in such states in order to conduct manufacturing and sales activities. To date, we are registered as both a motor vehicle manufacturer and dealer in Indiana and Ohio as well as a dealer in California and Chicago. We have not yet sought formal clarification of our ability to manufacture or sell our vehicles in any other states.

Intellectual Property

We have five pending trademark applications and two issued trademark registrations in the U.S. with intent to pursue foreign trademark registration as well. We have one pending U.S. patent application, six existing patents and also plan to pursue appropriate foreign patent protection on those inventions. The following is a summary of our patents:

Country	Status	Serial Number	Application Date	Patent Number	Issue /Grant Date	Title	Expiration Date
Canada	Granted	2523653	10/17/2005	2523653	12/22/2009	Vehicle Chassis Assembly	10/17/2025
United States	Granted	11/252,220	10/17/2005	7,717,464	5/18/2010	Vehicle Chassis Assembly	9/6/2026
United States	Granted	11/252,219	10/17/2005	7,559,578	7/14/2009	Vehicle Chassis Assembly	9/6/2026
United States	Granted	29/243,074	11/18/2005	D561,078	2/5/2008	Vehicle Header	2/5/2022
United States	Granted	29/243,129	11/18/2005	D561,079	2/5/2008	Vehicle Header	2/5/2022
United States	Granted	13/283,663	10/28/2011	8,541,915	9/24/2013	Drive Module And Manifold For Electric Motor Drive Assembly	12/16/2031
United States	Filed	61/933,350	1/30/2014	NA	NA	Onboard Generator Drive System For Electric Vehicles That Share An Electric Motor For Both Propulsion And Generation	1/30/2015

Agreements

Momentum Dynamics and BARTA (Berks County Regional Transportation Authority)

On December 29, 2012, the Company entered into an Agreement with Momentum Dynamics to engineer, develop, and produce two development vehicles for BARTA in Reading, Pennsylvania. We are seeking to have this project generate the following: promote the use of AMP products for other similar applications i.e. rental car shuttle buses, motel and hotel shuttle buses, school buses, and other hospitality shuttle bus applications, network the AMP products through the Momentum Dynamic sales channel, and promote the sale of AMP products to the Departments of Transportation throughout the US.

Navistar International Truck

In April of 2012 we signed a development agreement with Navistar International Truck. The scope of work for this project was to repower two 2004 vintage W1652 vehicles, which were originally produced by Navistar. Their customer, a large package delivery company, has an interest in repowering these vehicles with something other than the current diesel engine that is in this vehicle. Navistar was interested in working with them to repower these vehicles with either electric or some other fuel system. With electric being the most desirable if the customer's price point could be met, AMP was subcontracted by Navistar to perform the electric repower, and in August of 2012 AMP delivered the first vehicle to Navistar. The vehicle passed their initial performance requirements which were based on their end customer's specifications. In October 2012 Navistar turned the project over to AMP to work directly with them to provide a 100% electric repowered vehicle. Since that time, AMP has been working through the customer requirements and completed all stages of testing and durability.

Employees

We currently have 13 full-time and two part-time employees located in Loveland, Ohio and two full-time and one part-time employees located in Union City, Indiana. We also contract for hire with approximately 17 outside consultants and contractors. Three of our employees are engaged in administrative aspects of our business and 15 are involved in research and development. Ten of our contractors are involved in research and development and seven are involved in administration.

ITEM 1A. RISK FACTORS

Our results of operations have not resulted in profitability and we may not be able to achieve profitability going forward.

We have incurred net losses amounting to \$34.1 million for the period from inception (February 20, 2007) through December 31, 2014. In addition, as of December 31, 2014, we had a working capital deficiency of \$2.3 million. We have had net losses in each quarter since our inception. We expect that we will continue to incur net losses for the foreseeable future. We may incur significant losses in the future for a number of reasons, including the other risks described in this prospectus, and we may encounter unforeseen expenses, difficulties, complications, delays and other unknown events. Accordingly, we may not be able to achieve or maintain profitability. Our management is developing plans to alleviate the negative trends and conditions described above and there is no guarantee that such plans will be successfully implemented. Our business plan has changed from concentrating on the electric passenger vehicle market to the electric medium duty trucks, but is still unproven. There is no assurance that even if we successfully implement our business plan, that we will be able to curtail our losses. Further, as we are a development stage enterprise, we expect that net losses and the working capital deficiency will continue. If we incur additional significant operating losses, our stock price may decline, perhaps significantly.

We have yet to achieve positive cash flow and, given our projected funding needs, our ability to generate positive cash flow is uncertain.

We have had negative cash flow from operating activities of \$4.5 million and \$2.7 million for the years ended December 31, 2014 and 2013. We anticipate that we will continue to have negative cash flow from operating and investing activities for the foreseeable future as we expect to incur increased research and development, sales and marketing, and general and administrative expenses and make significant capital expenditures in our efforts to increase sales and commence operations at our Union City facility. Our business also will at times require significant amounts of working capital to support our growth, particularly as we acquire inventory to support our anticipated increase in production. An inability to generate positive cash flow for the foreseeable future may adversely affect our ability to raise needed capital for our business on reasonable terms, diminish supplier or customer willingness to enter into transactions with us, and have other adverse effects that may decrease our long-term viability. There can be no assurance we will achieve positive cash flow in the foreseeable future.

We need access to additional financing, which may not be available to us on acceptable terms or at all. For the year ended December 31, 2014, our independent registered public accounting firm issued a report on our 2014 financial statements that contains an explanatory paragraph stating that the lack of sales, negative working capital and stockholders' deficit, raise substantial doubt about our ability to continue as a going concern. If we cannot access additional financing when we need it and on acceptable terms, our business, prospects, financial condition, operating results and ability to continue as a going concern could be adversely affected.

Our growth-oriented business plan to design, produce, sell and service commercial electric vehicles through our Union City facility will require continued capital investment. Our research and development activities will require continued investment. For the year ended December 31, 2014, our independent registered public accounting firm issued a report on our 2014 financial statements that contains an explanatory paragraph stating that the lack of sales, negative working capital and stockholders' deficit, raise substantial doubt about our ability to continue as a going concern. In order to implement our operations through June 30, 2015, we will need to raise approximately \$10 million and to fully implement our business plan through December 31, 2016 we will need to raise approximately \$20 million. This capital will be necessary to fund our ongoing operations, continue research, development and design efforts, open our sales, service and assembly facilities, improve infrastructure and introduce new or improve existing vehicle models. We cannot be certain that additional financing will be available to us on favorable terms when required, or at all, particularly given that we do not now have a committed credit facility with any government or financial institution. If we cannot obtain additional financing when we need it and on terms acceptable to us, our business, prospects, financial condition, operating results and ability to continue as a going concern could be adversely affected.

Our limited operating history makes it difficult for us to evaluate our future business prospects and make decisions based on those estimates of our future performance.

We have basically been a research and development company since beginning operations in February 2007. We have a limited operating history and have generated limited revenue. As we move more toward a manufacturing environment it is difficult, if not impossible, to forecast our future results based upon our historical data. Because of the uncertainties related to our lack of historical operations, we may be hindered in our ability to anticipate and timely adapt to increases or decreases in revenues or expenses. If we make poor budgetary decisions as a result of unreliable historical data, we could be less profitable or incur losses, which may result in a decline in our stock price.

Failure to successfully integrate the Workhorse ® brand, logo, intellectual property, patents and assembly plant in Union City, Indiana into our operations could adversely affect our business and results of operations.

As part of our strategy to become an OEM, in March 2013, we acquired Workhorse and the Workhorse Assets including the Workhorse ® brand, logo, intellectual property, patents and assembly plant in Union City, Indiana. The Workhorse acquisition may expose us to operational challenges and risks, including the diversion of management's attention from our existing business, the failure to retain key Workhorse dealers and our ability to commence operations at the plant in Union City, Indiana. Our ability to sustain our growth and maintain our competitive position may be affected by our ability to successfully integrate the Workhorse Assets.

Our business, prospects, financial condition and operating results will be adversely affected if we cannot reduce and adequately control the costs and expenses associated with operating our business, including our material and production costs.

We incur significant costs and expenses related to procuring the materials, components and services required to develop and produce our electric vehicles. We have secured supply agreements for our critical components including our batteries. However, these are dependent on volume to ensure that they are available at a competitive price. As a result, our current cost projections are considerably higher than the projected revenue stream that such vehicles will produce. As a result we are continually working on initiatives to reduce our cost structure so that we may effectively compete. If we do not properly manage our costs and expenses our net losses will continue which will negatively impact our stock price.

If we are unable to pay off the outstanding amount owed under the debenture in the principal amount of \$2,250,000 that is secured against all of the assets of AMP Trucks including the Workhorse brand and the Union City facility and such lien holder were to take possession of such assets, our operations would be severely negatively impacted if not curtailed.

On March 4, 2013, AMP Trucks entered into an Asset Purchase Agreement with Workhorse Custom Chassis, LLC (“WCC”), an Illinois limited liability company and a wholly-owned affiliate of Navistar International Corporation, to purchase certain assets including the Workhorse® brand, logo, intellectual property, patents and approximately 250,000 sq. ft. of facilities on 48 acres of land in Union City, Indiana (the “Assets”). On March 13, 2013, AMP Trucks closed the acquisition of the Assets from WCC for a purchase price of \$5,000,000 of which \$2,750,000 was paid in cash and the delivery of a Secured Debenture (the “Debenture”) in the principal amount of \$2,250,000. The Debenture is secured pursuant to a Security Agreement (the “Security Agreement”) and a Mortgage, Security Agreement, Assignment of Rents and Fixture Filing (the “Mortgage”) entered between AMP Trucks and WCC. Pursuant to the Security Agreement, AMP Trucks granted WCC a security interest in all of the assets of AMP Trucks in order to secure the prompt payment, performance and discharge in full of all of obligations of AMP Trucks under the Debenture. Pursuant to the Mortgage, the Debenture is secured by the real estate and related assets of the plant located in Union City, Indiana. The Debenture matures three years from its effective date of March 13, 2013 (the “Maturity Date”) and interest associated with the Debenture is 10% per annum, which is payable on the Maturity Date. AMP Trucks may prepay outstanding principal and interest of the Debenture in full at any time. In the event AMP Trucks prepays outstanding principal and interest, it shall pay an amount equal to all outstanding principal and interest multiplied by 105%. AMP Holding and AMP guaranteed the payment of the Debenture.

Our future growth is dependent upon the willingness of operators of commercial vehicle fleets to adopt electric vehicles and on our ability to produce, sell and service vehicles that meet their needs. If the market for commercial electric vehicles does not develop as we expect or develops more slowly than we expect, our business, prospects, financial condition and operating results will be adversely affected.

Our growth is dependent upon the adoption of electric vehicles by operators of commercial vehicle fleets and on our ability to produce, sell and service vehicles that meet their needs. The entry of commercial electric vehicles into the medium-duty commercial vehicle market is a relatively new development, particularly in the United States, and is characterized by rapidly changing technologies and evolving government regulation, industry standards and customer views of the merits of using electric vehicles in their businesses. This process has been slow as without including the impact of government or other subsidies and incentives, the purchase prices for our commercial electric vehicles currently is higher than the purchase prices for diesel-fueled vehicles. As part of our sales efforts, we must educate fleet managers as to the economical savings during the life of the vehicle. As such, we believe that operators of commercial vehicle fleets consider a number of factors when deciding whether to purchase our commercial electric vehicles (or commercial electric vehicles generally) or vehicles powered by internal combustion engines, particularly diesel-fueled or natural gas-fueled vehicles. We believe these factors include:

- the difference in the initial purchase prices of commercial electric vehicles and vehicles with comparable GVWs powered by internal combustion engines, both including and excluding the impact of government and other subsidies and incentives designed to promote the purchase of electric vehicles;
- the total cost of ownership of the vehicle over its expected life, which includes the initial purchase price and ongoing operating and maintenance costs;
- the availability and terms of financing options for purchases of vehicles and, for commercial electric vehicles, financing options for battery systems;
- the availability of tax and other governmental incentives to purchase and operate electric vehicles and future regulations requiring increased use of nonpolluting vehicles;
- government regulations and economic incentives promoting fuel efficiency and alternate forms of energy;
- fuel prices, including volatility in the cost of diesel;
- the cost and availability of other alternatives to diesel fueled vehicles, such as vehicles powered by natural gas;
- corporate sustainability initiatives;
- commercial electric vehicle quality, performance and safety (particularly with respect to lithium-ion battery packs);
- the quality and availability of service for the vehicle, including the availability of replacement parts;
- the limited range over which commercial electric vehicles may be driven on a single battery charge;
- access to charging stations and related infrastructure costs, and standardization of electric vehicle charging systems;
- electric grid capacity and reliability; and
- macroeconomic factors.

If, in weighing these factors, operators of commercial vehicle fleets determine that there is not a compelling business justification for purchasing commercial electric vehicles, particularly those that we produce and sell, then the market for commercial electric vehicles may not develop as we expect or may develop more slowly than we expect, which would adversely affect our business, prospects, financial

condition and operating results.

If our customers are unable to efficiently and effectively integrate our electric vehicles into their existing commercial fleets our sales may suffer and our business, prospects, financial condition and operating results may be adversely affected.

Our sales strategy involves a comprehensive plan for the pilot and roll-out of our electric vehicles, as well as the ongoing replacement of existing commercial vehicles with our electric vehicles, that is tailored to the individual needs of our customers. If we are unable to develop and execute fleet integration strategies or fleet management support services that meet our customers' unique circumstances with minimal disruption to their businesses, our customers may not realize the economic benefits they expect from our electric vehicles. If this were to occur, our customers may not order additional vehicles from us, which could adversely affect our business, prospects, financial condition and operating results.

We currently do not have long-term supply contracts with guaranteed pricing which exposes us to fluctuations in component, materials and equipment prices. Substantial increases in these prices would increase our operating costs and could adversely affect our business, prospects, financial condition and operating results.

Because we currently do not have long-term supply contracts with guaranteed pricing, we are subject to fluctuations in the prices of the raw materials, parts and components and equipment we use in the production of our vehicles. Substantial increases in the prices for such raw materials, components and equipment would increase our operating costs and could reduce our margins if we cannot recoup the increased costs through increased vehicle prices. Any attempts to increase the announced or expected prices of our vehicles in response to increased costs could be viewed negatively by our customers and could adversely affect our business, prospects, financial condition and operating results.

If we are unable to scale our operations at our Union City facility in an expedited manner from our limited low volume production to high volume production, our business, prospects, financial condition and operating results could be adversely affected.

We are currently assembling our orders at our Union City facility which is acceptable for our existing orders. In order to satisfy increased demand, we will need to quickly scale operations in our Union City facility as well as scale our supply chain including access to batteries. Our business, prospects, financial condition and operating results could be adversely affected if we experience disruptions in our supply chain, if we cannot obtain materials of sufficient quality at reasonable prices or if we are unable to scale our Union City facility.

We depend upon key personnel and need additional personnel.

Our success depends on the continuing services of Stephen Burns, CEO, and Martin J. Rucidlo, President. On December 8, 2010, we entered into an employment agreement with Mr. Burns for a term of two years which automatically renews for one year periods unless either of the parties elects to not renew for such period. Mr. Rucidlo is not engaged under a long-term employment agreement. The loss of any of these individuals could have a material and adverse effect on our business operations. Additionally, the success of our operations will largely depend upon its ability to successfully attract and maintain competent and qualified key management personnel. As with any company with limited resources, there can be no guarantee that we will be able to attract such individuals or that the presence of such individuals will necessarily translate into profitability for our company. Our inability to attract and retain key personnel may materially and adversely affect our business operations. Any failure by our management to effectively anticipate, implement, and manage the changes required to sustain our growth would have a material adverse effect on our business, financial condition, and results of operations.

We face competition. A few of our competitors have greater financial or other resources, longer operating histories and greater name recognition than we do and one or more of these competitors could use their greater resources and/or name recognition to gain market share at our expense or could make it very difficult for us to establish market share.

Companies currently competing in the fleet logistics market offering alternative fuel medium duty trucks include Ford Motor Company and Freightliner. In the electric medium duty truck market in the United States, we compete with a few other manufacturers, including Electric Vehicles International and Smith Electric Vehicles. Ford and Freightliner have more significant financial resources, established market positions, long-standing relationships with customers and dealers, and who have more significant name recognition, technical, marketing, sales, financial and other resources than we do. Ford and Freightliner are currently selling alternative fuel fleet vehicles including hybrids. The resources available to our competitors to develop new products and introduce them into the marketplace exceed the resources currently available to us. As a result, our competitors may be able to compete more aggressively and sustain that competition over a longer period of time that we can. This intense competitive environment may require us to make changes in our products, pricing, licensing, services, distribution, or marketing to develop a market position. Each of these competitors has the potential to capture market share in our target markets which could have an adverse effect on our position in our industry and on our business and operating results.

If we are unable to keep up with advances in electric vehicle technology, we may suffer a decline in our competitive position.

There are companies in the electric vehicle industry that have developed or are developing vehicles and technologies that compete or will compete with our vehicles. We cannot assure that our competitors will not be able to duplicate our technology or provide products and services similar to ours more efficiently. If for any reason we are unable to keep pace with changes in electric vehicle technology, particularly battery technology, our competitive position may be adversely affected. We plan to upgrade or adapt our vehicles and introduce new models in order to continue to provide electric vehicles that incorporate the latest technology. However, there is no assurance that our research and development efforts will keep pace with those of our competitors.

Our electric vehicles compete for market share with vehicles powered by other vehicle technologies that may prove to be more attractive than ours.

Our target market currently is serviced by manufacturers with existing customers and suppliers using proven and widely accepted fuel technologies. Additionally, our competitors are working on developing technologies that may be introduced in our target market. If any of these alternative technology vehicles can provide lower fuel costs, greater efficiencies, greater reliability or otherwise benefit from other factors resulting in an overall lower total cost of ownership, this may negatively affect the commercial success of our vehicles or make our vehicles uncompetitive or obsolete.

We currently have a limited number of customers, with whom we do not have long-term agreements, and expect that a significant portion of our future sales will be from a limited number of customers and the loss of any of these high volume customers could materially harm our business.

A significant portion of our projected future revenue, if any, is generated from a limited number of vehicle customers. Additionally, much of our business model is focused on building relationships with large customers. Currently we have no contracts with customers that include long-term commitments or minimum volumes that ensure future sales of vehicles. As such, a customer may take actions that affect us for reasons that we cannot anticipate or control, such as reasons related to the customer's financial condition, changes in the customer's business strategy or operations or as the result of the perceived performance or cost-effectiveness of our vehicles. The loss of or a reduction in sales or anticipated sales to our most significant customers could have an adverse effect on our business, prospects, financial condition and operating results.

Changes in the market for electric vehicles could cause our products to become obsolete or lose popularity.

The modern electric vehicle industry is in its infancy and has experienced substantial change in the last few years. To date, demand for and interest in electric vehicles has been slower than forecasted by industry experts. As a result, growth in the electric vehicle industry depends on many factors, including, but not limited to:

- continued development of product technology, especially batteries
- the environmental consciousness of customers
- the ability of electric vehicles to successfully compete with vehicles powered by internal combustion engines
- limitation of widespread electricity shortages; and
- whether future regulation and legislation requiring increased use of non-polluting vehicles is enacted

We cannot assume that growth in the electric vehicle industry will continue. Our business may suffer if the electric vehicle industry does not grow or grows more slowly than it has in recent years or if we are unable to maintain the pace of industry demands.

The unavailability, reduction, elimination or adverse application of government subsidies, incentives and regulations could have an adverse effect on our business, prospects, financial condition and operating results.

We believe that, currently, the availability of government subsidies and incentives including those available in New York, California and Chicago is an important factor considered by our customers when purchasing our vehicles, and that our growth depends in part on the availability and amounts of these subsidies and incentives. Any reduction, elimination or discriminatory application of government subsidies and incentives because of budgetary challenges, policy changes, the reduced need for such subsidies and incentives due to the perceived success of electric vehicles or other reasons may result in the diminished price competitiveness of the alternative fuel vehicle industry.

We may be unable to keep up with changes in electric vehicle technology and, as a result, may suffer a decline in our competitive position.

Our current products are designed for use with, and are dependent upon, existing electric vehicle technology. As technologies change, we plan to upgrade or adapt our products in order to continue to provide products with the latest technology. However, our products may become obsolete or our research and development efforts may not be sufficient to adapt to changes in or to create the necessary technology. As a result, our potential inability to adapt and develop the necessary technology may harm our competitive position.

The failure of certain key suppliers to provide us with components could have a severe and negative impact upon our business.

We have secured supply agreements for our critical components including our batteries. However, these are dependent on volume to ensure that they are available at a competitive price. Further, we rely on a small group of suppliers to provide us with components for our products. If these suppliers become unwilling or unable to provide components or if we are unable to meet certain volume requirements in our existing supply agreements, there are a limited number of alternative suppliers who could provide them. Changes in business conditions, wars, governmental changes, and other factors beyond our control or which we do not presently anticipate could affect our ability to receive components from our suppliers. Further, it could be difficult to find replacement components if our current suppliers fail to provide the parts needed for these products. A failure by our major suppliers to provide these components could severely restrict our ability to manufacture our products and prevent us from fulfilling customer orders in a timely fashion.

Product liability or other claims could have a material adverse effect on our business.

The risk of product liability claims, product recalls, and associated adverse publicity is inherent in the manufacturing, marketing, and sale of electrical vehicles. Although we have product liability insurance for our consumer and commercial products, that insurance may be inadequate to cover all potential product claims. We also carry liability insurance on our products. Any product recall or lawsuit seeking significant monetary damages either in excess of our coverage, or outside of our coverage, may have a material adverse effect on our business and financial condition. We may not be able to secure additional product liability insurance coverage on acceptable terms or at reasonable costs when needed. A successful product liability claim against us could require us to pay a substantial monetary award. Moreover, a product recall could generate substantial negative publicity about our products and business and inhibit or prevent commercialization of other future product candidates. We cannot provide assurance that such claims and/or recalls will not be made in the

We may have to devote substantial resources to implementing a retail product distribution network.

Dealers are often hesitant to provide their own financing to contribute to our product distribution network. As a result, we anticipate that we may have to provide financing or other consignment sale arrangements for dealers. A capital investment such as this presents many risks, foremost among them being that we may not realize a significant return on our investment if the network is not profitable. Our inability to collect receivables from dealers could cause us to suffer losses. Lastly, the amount of time that our management will need to devote to this project may divert them from performing other functions necessary to assure the success of our business.

Regulatory requirements may have a negative impact upon our business.

While our vehicles are subject to substantial regulation under federal, state, and local laws, we believe that our vehicles are or will be materially in compliance with all applicable laws. However, to the extent the laws change, or if we introduce new vehicles in the future, some or all of our vehicles may not comply with applicable federal, state, or local laws. Further, certain federal, state, and local laws and industrial standards currently regulate electrical and electronics equipment. Although standards for electric vehicles are not yet generally available or accepted as industry standards, our products may become subject to federal, state, and local regulation in the future. Compliance with these regulations could be burdensome, time consuming, and expensive.

Our products are subject to environmental and safety compliance with various federal and state regulations, including regulations promulgated by the EPA, NHTSA, and various state boards, and compliance certification is required for each new model year. The cost of these compliance activities and the delays and risks associated with obtaining approval can be substantial. The risks, delays, and expenses incurred in connection with such compliance could be substantial.

Our success may be dependent on protecting our intellectual property rights.

We rely on trade secret protections to protect our proprietary technology as well as several registered patents and one patent application. Our patents relate to the vehicle chassis assembly, vehicle header and drive module and manifold for electric motor drive assembly. Our existing patent application relates to the onboard generator drive system for electric vehicles. Our success will, in part, depend on our ability to obtain additional trademarks and patents. We are working on obtaining patents and trademarks registered with the United States Patent and Trademark Office but have not finalized any as of this date. Although we have entered into confidentiality agreements with our employees and consultants, we cannot be certain that others will not gain access to these trade secrets. Others may independently develop substantially equivalent proprietary information and techniques or otherwise gain access to our trade secrets.

We may be exposed to liability for infringing upon the intellectual property rights of other companies.

Our success will, in part, depend on our ability to operate without infringing on the proprietary rights of others. Although we have conducted searches and are not aware of any patents and trademarks which our products or their use might infringe, we cannot be certain that infringement has not or will not occur. We could incur substantial costs, in addition to the great amount of time lost, in defending any patent or trademark infringement suits or in asserting any patent or trademark rights, in a suit with another party.

Our electric vehicles make use of lithium-ion battery cells, which, if not appropriately managed and controlled, on rare occasions have been observed to catch fire or vent smoke and flames. If such events occur in our electric vehicles, we could face liability for damage or injury, adverse publicity and a potential safety recall, any of which could adversely affect our business, prospects, financial condition and operating results.

The battery packs in our electric vehicles use lithium-ion cells, which have been used for years in laptop computers and cell phones. On rare occasions, if not appropriately managed and controlled, lithium-ion cells can rapidly release the energy they contain by venting smoke and flames in a manner that can ignite nearby materials.

Our facilities could be damaged or adversely affected as a result of disasters or other unpredictable events. Any prolonged disruption in the operations of our facility would adversely affect our business, prospects, financial condition and operating results.

We engineer and assemble our electric vehicles in a facility in Loveland, Ohio and we intend to locate the assembly function to our facility in Union City. Any prolonged disruption in the operations of our facility, whether due to technical, information systems, communication networks, accidents, weather conditions or other natural disaster, or otherwise, whether short or long-term, would adversely affect our business, prospects, financial condition and operating results .

We have never paid cash dividends on our common stock and do not anticipate paying cash dividends in the foreseeable future. The payment of dividends on our common stock will depend on earnings, financial condition and other business and economic factors affecting the company at such time as the board of directors may consider relevant. If we do not pay dividends, our common stock may be less valuable because a return on investment will only occur due to stock price appreciation.

Our stock price and trading volume may be volatile, which could result in substantial losses for our stockholders.

The equity trading markets may experience periods of volatility, which could result in highly variable and unpredictable pricing of equity securities. The market price of our common stock could change in ways that may or may not be related to our business, our industry or our operating performance and financial condition. In addition, the trading volume in our common stock may fluctuate and cause significant price variations to occur. We have experienced significant volatility in the price of our stock. We cannot assure that the market price of our common stock will not fluctuate or decline significantly in the future. In addition, the stock markets in general can experience considerable price and volume fluctuations.

We have not voluntarily implemented various corporate governance measures, in the absence of which, shareholders may have more limited protections against interested director transactions, conflict of interest and similar matters.

Recent Federal legislation, including the Sarbanes-Oxley Act of 2002, has resulted in the adoption of various corporate governance measures designed to promote the integrity of the corporate management and the securities markets. Some of these measures have been adopted in response to legal requirements. Others have been adopted by companies in response to the requirements of national securities exchanges, such as the NYSE or the NASDAQ, on which their securities are listed. Prospective investors should bear in mind our current lack of Sarbanes Oxley measures in formulating their investment decisions.

We may be exposed to potential risks relating to our internal controls over financial reporting and our ability to have those controls attested to by our independent auditors.

As directed by Section 404 of the Sarbanes-Oxley Act of 2002 ("SOX 404"), the Securities and Exchange Commission adopted rules requiring smaller reporting companies, such as our company, to include a report of management on the company's internal controls over financial reporting in their annual reports for fiscal years ending on or after December 15, 2007. We were required to include the management report in annual reports starting with the year ending December 31, 2009. Previous SEC rules required a non-accelerated filer to include an attestation report in its annual report for years ending on or after June 15, 2010. Section 989G of the Dodd-Frank Act added SOX Section 404(c) to exempt from the attestation requirement smaller issuers that are neither accelerated filers nor large accelerated filers under Rule 12b-2. Under Rule 12b-2, subject to periodic and annual reporting criteria, an "accelerated filer" is an issuer with market value of \$75 million, but less than \$700 million; a "large accelerated filer" is an issuer with market value of \$700 million or greater. As a result, the exemption effectively applies to companies with less than \$75 million in market capitalization.

The trading of our common stock is limited under the SEC's penny stock regulations, which will adversely affect the liquidity of our common stock.

The trading price of our common stock is currently less than \$5.00 per share and, as a result, our common stock is considered a "penny stock", and trading in our common stock would be subject to the requirements of Rule 15c-9 under the Exchange Act. Under this rule, broker/dealers who recommend low-priced securities to persons other than established customers and accredited investors must satisfy special sales practice requirements. Generally, the broker/dealer must make an individualized written suitability determination for the purchaser and receive the purchaser's written consent prior to the transaction.

SEC regulations also require additional disclosure in connection with any trades involving a "penny stock," including the delivery, prior to any penny stock transaction, of a disclosure schedule explaining the penny stock market and its associated risks. These requirements severely limit the liquidity of securities in the secondary market because few broker or dealers are likely to undertake these compliance activities. In addition to the applicability of the penny stock rules, other risks associated with trading in penny stocks could also be price fluctuations and the lack of a liquid market. An active and liquid market in our common stock may never develop due to these factors.

ITEM 1B. UNRESOLVED STAFF COMMENTS

None.

ITEM 2. PROPERTIES

Our principal offices are located at 100 Commerce Drive, Loveland, Ohio 45247, which include 7,500 square feet in office space and 22,500 square feet in manufacturing/development space. We pay \$12,231 per month in rent and our current lease expires in September 2018. At December 31, 2014 approximately \$5.3 thousand is included in accounts payable for amounts due to the lessor. On March 13, 2013 the Company acquired the operating assets of Workhorse Custom Chassis, LLC, an unrelated company located in Union City, Indiana. The following summarizes the consideration paid, and the components of the purchase price and the related allocation of assets acquired and liabilities assumed:

<u>Consideration</u>	
Cash at closing	2,750,000
Secured debenture	2,250,000
	<u>5,000,000</u>
<u>Assets acquired</u>	
Inventory	400,000
Equipment	500,000
Land	300,000
Buildings	3,800,000
	<u>5,000,000</u>

The following table sets forth the location, approximate size and primary use of our principal owned, leased and licensed facilities:

Location	Approximate Size (Building) in Square Feet	Primary Use	Owned, Leased or Licensed	Lease/ License Expiration Date (if applicable)
Loveland, Ohio	30,000	Administration, research and development and manufacturing	Leased	Sep-18
Union City, Indiana	270,000	Manufacturing	N/A	N/A

ITEM 3. LEGAL PROCEEDINGS

We are currently not a party to any legal or administrative proceedings and are not aware of any pending or threatened legal or administrative proceedings against us in all material aspects. We may from time to time become a party to various legal or administrative proceedings arising in the ordinary course of our business.

ITEM 4. MINE SAFETY DISCLOSURES

Not applicable.

PART II

ITEM 5. MARKET FOR REGISTRANT'S COMMON EQUITY, RELATED STOCKHOLDER MATTERS AND ISSUER PURCHASES OF EQUITY SECURITIES

Market Information

Our common stock was quoted on the OTCBB and OTCQB under the symbol "TTSO" from July 14, 2009 through May 24, 2010 and then under the symbol "AMPD" from May 24, 2010 to present. The following table sets forth the range of high and low prices per share of our common stock for each period indicated.

Quarter Ended		2014	2013
March 31	High	\$ 0.17	\$ 0.37
	Low	\$ 0.10	\$ 0.12
June 30	High	\$ 0.14	\$ 0.53
	Low	\$ 0.10	\$ 0.23
September 30	High	\$ 0.34	\$ 0.51
	Low	\$ 0.08	\$ 0.23
December 31	High	\$ 0.23	\$ 0.30
	Low	\$ 0.12	\$ 0.10

Holders of our Common Stock

As of March 27, 2015, there were approximately 92 stockholders of record of our common stock. This number does not include shares held by brokerage clearing houses, depositories or others in unregistered form. The stock transfer agent for our securities is Empire Stock Transfer, Inc., 1859 Whitney Mesa Drive, Henderson, Nevada 89014.

Dividends

The Company has never declared or paid any cash dividends on its common stock. The Company currently intends to retain future earnings, if any, to finance the expansion of its business. As a result, the Company does not anticipate paying any cash dividends in the foreseeable future.

Securities Authorized for Issuance Under Equity Compensation Plans

The following table sets forth the aggregate information of our equity compensation plans in effect as of December 31, 2014:

Plan	Number of securities to be issued upon exercise of outstanding options and rights	Weighted-average exercise price of outstanding options and rights	Number of securities remaining available for future issuance under equity compensation plans (excluding securities reflected in first column)
Equity compensation plans approved by security holders – 2010 Stock Incentive Plan	1,582,000	\$ 0.42	388,250
Equity compensation plans approved by security holders – 2011 Incentive Stock Plan	225,000	\$ 0.70	775,000
Equity compensation plans or arrangements not approved by security holders - 2012 Incentive Stock Plan	21,753,565	\$ 0.77	1,441,500
Equity compensation plans or arrangements not approved by security holders - 2013 Incentive Stock Plan	5,000,000	\$ 0.28	0
Equity compensation plans or arrangements not approved by security holders - 2014 Incentive Stock Plan	37,000,000	\$ 0.25	0
Total	65,560,565	\$ 0.75	2,604,750

Penny Stock Rules

The Securities and Exchange Commission has adopted rules that regulate broker-dealer practices in connection with transactions in penny stocks. Penny stocks are generally equity securities with a price of less than \$5.00 (other than securities registered on certain national securities exchanges or quoted on the NASDAQ system, provided that current price and volume information with respect to transactions in such securities is provided by the exchange or system).

Our shares constitute penny stock under the Securities and Exchange Act. The shares will remain penny stocks for the foreseeable future. The classification of penny stock makes it more difficult for a broker-dealer to sell the stock into a secondary market, which makes it more difficult for a stockholder to liquidate his or her shares. Any broker-dealer engaged by the purchaser for the purpose of selling his or her shares in the Company will be subject to Rules 15g-1 through 15g-10 of the Securities and Exchange Act. Rather than creating a need to comply with those rules, some broker-dealers will refuse to attempt to sell penny stock.

The penny stock rules require a broker-dealer, prior to a transaction in a penny stock not otherwise exempt from those rules, to deliver a standardized risk disclosure document, which:

- contains a description of the nature and level of risk in the market for penny stock in both public offerings and secondary trading
- contains a description of the broker's or dealer's duties to the customer and of the rights and remedies available to the customer with respect to a violation of such duties or other requirements of the Securities Act of 1934, as amended
- contains a brief, clear, narrative description of a dealer market, including "bid" and "ask" price for the penny stock and the significance of the spread between the bid and ask price
- contains a toll-free telephone number for inquiries on disciplinary actions
- defines significant terms in the disclosure document or in the conduct of trading penny stocks
- contains such other information and is in such form (including language, type, size and format) as the Securities and Exchange Commission shall require by rule or regulation

The broker-dealer also must provide, prior to effecting any transaction in a penny stock, to the customer:

- the bid and offer quotations for the penny stock
- the compensation of the broker-dealer and its salesperson in the transaction
- the number of shares to which such bid and ask prices apply, or other comparable information relating to the depth and liquidity of the market for such stock
- monthly account statements showing the market value of each penny stock held in the customer's account

In addition, the penny stock rules require that prior to a transaction in a penny stock not otherwise exempt from those rules; the broker-dealer must make a special written determination that the penny stock is a suitable investment for the purchaser and receive the purchaser's written acknowledgment of the receipt of a risk disclosure statement, a written agreement to transactions involving penny stocks, and a signed and dated copy of a written suitability statement. These disclosure requirements will have the effect of reducing the trading activity in the secondary market for our stock because it will be subject to these penny stock rules. Therefore, stockholders may have difficulty selling their securities.

Unregistered Sales of Equity Securities

From January 6, 2012 through August 3, 2012, the Company entered into Securities Purchase Agreements and Security Agreements with several accredited investors (the "2012 Investors") providing for the sale by the Company to the 2012 Investors of Secured Convertible Debentures in the aggregate amount of \$1,939,250 (the "2012 Notes"). In addition to the 2012 Notes, the 2012 Investors also received common stock purchase warrants (the "2012 Warrants") to acquire 1,939,250 shares of common stock of the Company. The 2012 Warrants were exercisable for three years at an exercise price of \$0.50. The Company received the proceeds in connection with these financings between January 6, 2012 and August 3, 2012. Further, a shareholder, director and officer, converted secured and unsecured loans provided to the Company from December 31, 2011 to June 5, 2012 in the aggregate amount of \$389,250 into the 2012 Notes and 2012 Warrants. In November 2012, the Company entered into a Note and Warrant Amendment and Conversion Agreement whereby the holders and the 2012 Investors converted all principal and interest under the 2012 Notes into 10,227,070 shares of common stock. Further, the exercise price of the 2012 Warrants was reduced to \$0.25 per share.

In March 2012 the Company settled outstanding invoices for consulting services totaling \$60,000 by issuing 177,515 shares of common stock.

On August 10, 2012, Company granted James Taylor options to purchase 300,000 shares of the Company's common stock at an exercise price of \$0.15 per share. The options expire after five years with 100,000 options vesting immediately and 100,000 options vesting each of the following two years on the anniversary date.

On August 20, 2012, the Company entered into an Investment Agreement ("Investment Agreement") with Kodiak Capital Group, LLC ("Kodiak"). Pursuant to the Investment Agreement, Kodiak has committed to purchase up to \$7,500,000 of the Company's common stock during the period commencing upon the effective date of a registration statement registering the shares of common stock underlying the equity line (the "Equity Line") and continuing for 24 months. The aggregate number of shares issuable by the Company and purchasable by Kodiak under the Investment Agreement will be determined by the purchase prices for the common stock, as determined under the terms of the Investment Agreement. Upon execution of the Investment Agreement, the Company issued to Kodiak 1,875,000 commitment shares of newly-issued common stock.

Contemporaneously with the execution and delivery of the Investment Agreement, the Company and Kodiak executed and delivered a Registration Rights Agreement ("Registration Rights Agreement") pursuant to which the Company has agreed to provide certain registration rights under the 1933 Act, and the rules and regulations promulgated thereunder, and applicable state securities laws.

The Company may draw on the facility from time to time, as and when it determines appropriate in accordance with the terms and conditions of the Investment Agreement. The amount that the Company is entitled to put in any one notice shall be up to \$75,000, at the Company's election. Kodiak's purchase price for each put is set at ninety percent (90%) of the lowest posted closing bid price of the Company's common stock during the five (5) trading days after the date of the put notice. The Company will not be entitled to put shares to Kodiak unless (a) there is an effective registration statement under the Securities Act to cover the sale of the shares to Kodiak, (b) the Company's common stock continues to be quoted on the OTC Bulletin Board, or becomes listed on a national securities exchange, and (c) the issuance of the shares would not cause Kodiak's beneficial ownership to exceed 9.99% of the outstanding shares.

Pursuant to the terms of the Registration Rights Agreement, the Company has agreed to use its best efforts to file a registration statement with the SEC to register the sale to Kodiak of shares of common stock issued or issuable under the Investment Agreement.

On August 24, 2012, Martin J. Rucidlo was engaged by the Company to serve as the President of the Company. Mr. Rucidlo replaced Stephen S. Burns who resigned as President. Mr. Burns continues to serve as a director as well as Chief Executive Officer, Secretary and Treasurer of the Company. On August 24, 2012, Mr. Rucidlo entered into a letter agreement with the Company pursuant to which he was appointed as the President of the Company in consideration of an annual salary of \$125,000. As additional compensation, the Company granted Mr. Rucidlo options to purchase 300,000 shares of the Company's common stock at an exercise price of \$0.21 per share. The options will expire three years from the vesting period with 90,000 options vesting upon the signing of the Agreement and 105,000 options vesting each of the following two years on the anniversary date of the Agreement for a total of 300,000 shares.

In September 2012, the Company settled outstanding invoices for legal services totaling \$40,000 by issuing 400,000 shares of common stock.

In October 2012, the Company settled outstanding invoices for consulting services totaling \$55,000 by issuing 500,000 shares of common stock.

Between October 16, 2012 and December 19, 2012, shareholders and related parties advanced \$500,000 to the Company for working capital needs. In consideration of such advances, the Company issued promissory notes with interest at 10% per annum due October 16, 2013. The notes are unsecured and require the Company to designate part of the proceeds of financing in excess of \$2,000,000 to be used for repayment of these notes. The Company is in violation of this covenant in 2013 as financing in excess of \$2,000,000 has occurred and repayment of these notes has not occurred.

In November 2012, the Company settled outstanding invoices for legal services totaling \$15,000 by issuing 157,895 shares of common stock.

In December 2012, the Company settled outstanding invoices for consulting services totaling \$175,000 by issuing 3,500,000 shares of common stock.

In December 2012, the Company entered into placement agent agreements with Northeast Securities Inc. and Midtown Partners & Company, LLC. The Company issued 25,000 shares of common stock to Northeast Securities Inc. and 150,000 shares of common stock to Midtown Partners & Co., LLC, with a cost basis of \$0.16 per share, as up-front compensation under the agreements.

On December 4, 2012, the Company granted stock options to acquire 1,575,000 shares of common stock to officers, employees and consultants under the 2012 Incentive Stock Plan at an exercise price of \$0.11 per share for a period of three years vesting 34% on December 31, 2014 8.35% at the end of each quarter thereafter for eight quarters, ending December 31, 2014.

In December 2012, the Company settled outstanding invoices for legal services totaling \$25,000 by issuing 208,333 shares of common stock.

On January 29, 2013, the Company entered into a subscription agreement with an accredited investor pursuant to which the investor purchased 500,000 shares of the Company's common stock at a cost basis of \$0.20 per share, for a purchase price of \$100,000, together with a common stock purchase warrant to acquire 250,000 shares of common stock at \$0.40 per share for a period of three years.

In addition, on January 29, 2013, an accredited investor loaned the Company \$100,000. In consideration of such loan, the Company issued a Promissory Note which bears interest at 10% per annum and matures on January 29, 2014. The Note can be prepaid in whole or in part at any time without the consent of the holder provided that the Company shall pay all accrued interest on the principal so prepaid to date of such prepayment. On February 21, 2013, the Company and the holder entered into a Conversion Agreement pursuant to which the parties converted the Note of January 29, 2013 into 500,000 shares of common stock of the Company at a cost basis of \$0.20 per share and a common stock purchase warrant to acquire 250,000 shares of common stock of the Company. The warrant is exercisable for three years at an exercise price of \$0.40.

On March 13, 2013, the Company entered into a subscription agreement with various accredited investors pursuant to which the Investors purchased 17,925,000 shares of the Company's common stock at a cost basis of \$0.20 per share, for a purchase price of \$3,585,000, together with common stock purchase warrants to acquire 8,962,500 shares of common stock at \$0.40 per share for a period of three years.

On March 13, 2013 the Company agreed to compensate a business development consultant for work performed relating to the Workhorse Custom Chassis purchase by issuing 1,125,000 shares of common stock at a cost basis of \$0.20 per share and a cash payment of \$25,000. Additionally, on March 13, 2013 the Company agreed to compensate a consultant that performed due diligence work related to the Workhorse Custom Chassis purchase by issuing 50,000 shares of common stock at a cost basis of \$0.23 per share.

On March 15, 2013 the Company established the 2013 Incentive Stock Plan to retain directors, executives and selected employees and consultants and reward them for making major contributions to the success of the Company. The total number of shares of common stock that may be purchased by Options, Stock Awards, or Restricted Stock Purchase Offers may not exceed 5,000,000. The exercise price of the options shall be no less than 100% of the Fair Market Value of the stock as of the date of grant, unless the holder owns more than 10% of the Company Stock in which case the Fair Market Value shall be no less than 110%. The exercise period shall be no more than five years. No shares shall become exercisable until the first anniversary date. Shares exercisable on the first anniversary date shall be 20% or more. On March 15, 2013 the Company granted 1,100,000 common stock options, from the 2013 Incentive Stock Plan, to certain executives and employees of the Company for work on the Workhorse Custom Chassis purchase. The options are exercisable at \$0.29 per share for a period of five years and vest 20% on March 15, 2014, 20% on March 15, 2015, 20% on March 15, 2016 and 40% on March 15, 2017.

On March 19, 2013 the Company agreed to compensate a new Advisory Board Member by issuing 300,000 shares of common stock at a cost basis of \$0.25 per share and a common stock option to acquire 50,000 shares at an exercise price of \$0.25 per share for a period of five years, with 16,666 vesting on the first anniversary date and 16,667 vesting on each of the next two anniversary dates.

On March 21, 2013, the Company settled outstanding invoices for legal services totaling \$40,000 by issuing 266,667 shares of common stock at a cost basis of \$0.15 per share.

On April 15, 2013 the Company agreed to compensate a sales and marketing consultant for services performed by issuing 25,000 shares of common stock per month. The agreement is for a term of six months and may be terminated by either party with 30 days written notice. The Company also agreed to compensate the consultant based on performance in securing sales for the Company by issuing up to 500,000 shares of restricted common stock in the form of shares or options at the discretion of the consultant. On June 30, 2013, as payment for services performed from April 15 to June 30, 2013, 62,500 shares were issued at a cost basis of \$0.3724 per share. Additionally, on July 31, 25,000 shares were issued at a cost basis of \$0.4005 per share for payment of July services.

On May 10, 2013, the Company entered into a subscription agreement with various accredited investors pursuant to which the investors purchased 2,575,000 shares of the Company's common stock at a cost basis of \$0.20 per share, for a purchase price of \$515,000, together with common stock purchase warrants to acquire 1,287,500 shares of common stock at \$0.40 per share for a period of three years.

On May 30, 2013, the Company entered into a subscription agreement with various accredited investors pursuant to which the investors purchased 250,000 shares of the Company's common stock at a cost basis of \$0.20 per share, for a purchase price of \$50,000, together with common stock purchase warrants to acquire 125,000 shares of common stock at \$0.40 per share for a period of three years.

On May 10, 2013, 18,764 shares of the Company's common stock were issued upon the exercise of 21,126 stock options and proceeds of \$1,161.

On May 10, 2013 the Company settled outstanding invoices for consulting services totaling \$126,000 by issuing 500,000 shares of common stock.

On June 5, 2013, 200,000 shares of common stock were issued for consulting services valued at \$54,800 related to introducing the Company to prospective investors. Additionally, on June 20, 2013, 100,000 shares of common stock were issued for consulting services valued at \$41,000 related to introducing the Company to investors.

On June 28, 2013, the Company settled outstanding invoices for legal services totaling \$15,000 by issuing 40,594 shares of common stock at a cost basis of \$0.3695 per share.

On June 28, 2013, the Company entered into a subscription agreement with various accredited investors pursuant to which the investors purchased 158,125 shares of the Company's common stock at a cost basis of \$0.32 per share, for a purchase price of \$50,600, together with common stock purchase warrants to acquire 79,063 shares of common stock at \$0.64 per share for a period of three years.

On July 1, 2013, the Company settled outstanding invoices for legal services totaling \$10,000 by issuing 27,062 shares of common stock at a cost basis of \$0.3695 per share.

On August 15, 2013, Julio C. Rodriguez was named the Chief Financial Officer of the Company, replacing Richard J. Calme, who resigned as Interim Chief Financial Officer and was appointed Director of Finance of the Company. Pursuant to the terms of the Employment Agreement, Mr. Rodriguez shall receive an annual salary of \$150,000. As additional compensation Mr. Rodriguez was granted options to acquire 300,000 shares of common stock at an exercise price of \$0.40 per share for a period of five years. Mr. Rodriguez is a finance executive with over 30 years experience in financial and operational leadership roles within various industries including the automotive industry.

On October 24, 2013 Raymond J. Chess was appointed as a director of AMP Holding Inc. Mr. Chess entered into a letter of agreement with the Company to receive an annual fee of \$40,000 and options to purchase 500,000 shares of the Company at \$0.26 per share over a five year period, vesting at 100,000 immediately and 40,000 every six months thereafter for a total of 500,000 shares. Mr. Chess has past experience with General Motors Co. (GM) where he had responsibility for global management of GM's crossover market segment and commercial truck segment.

On December 11, 2013, the Company entered into a Promissory Note with JMJ Financial in the principal amount up to \$335,000 of which only \$80,000 was funded. On March 7, 2014, the Company paid the outstanding balance owed under the Note and, as a result, has no further obligations to JMJ under the Note.

On January 17, 2014 the Company entered an Incentive Stock Options plan to be granted to officers or directors, provided they are also employees of the Company.

On March 18, 2014, the Company entered into a Subscription Agreement with Joseph T. Lukens ("Lukens"), an existing shareholder and an accredited investor, whereby Lukens agreed to acquire 30,000,000 shares of common stock and Common Stock Purchase Warrants to acquire 15,000,000 shares of common stock in consideration of \$3,000,000.

On April 22, 2014, Company Common Stock of 564,814 shares at a cost basis of \$0.108 was issued to 13 contractors for accounting, IT, sales and engineering work.

As of May 2014, the Company entered into subscription agreement with accredited investors ("May 2014 Investors") pursuant to which the May 2014 Investors purchased 14,280,000 shares of common stock for a purchase price of \$1,428,000, together with a common stock purchase warrants to acquire 7,140,000 shares of common stock at \$0.15 per share for a period of three years.

On May 16, 2014, the Company made a final settlement payment of \$140,000 to EASi (Parent Company Aerotek) for past engineering services that cancelled a note payable with varying monthly payments due through December, 2014, totaling \$169,753.

As of May 2014, the Company entered into conversion agreements with debt holders of the Company that were accredited investors ("May 2014 Conversion Investors") pursuant to which the May 2014 Conversion Investors converted \$1,169,300 into 11,693,000 shares of common stock together with a common stock purchase warrants to acquire 5,846,500 shares of common stock at \$0.15 per share for a period of three years.

In July 2014, the Company issued options to consultants to acquire 401,967 shares of common stock for a period of five years at an exercise price of \$0.01 per share. The options were issued in lieu of accrued compensation in the aggregate amount of \$36,568.

In July 2014, the Company issued options to executive officers and directors of the Company to acquire 4,180,674 shares of common stock for a period of five years at an exercise price of \$0.01 per share. The options were issued in lieu of accrued compensation in the aggregate amount of \$380,328.

In July 15, 2014, the Company issued an option to a consultant to acquire 238,975 shares of common stock for a period of five years at an exercise price of \$0.01 per share. The options were issued in lieu of accrued compensation in the aggregate amount of \$26,287.

In November 2014, the Company issued an option to a law firm to acquire 276,785 shares of common stock for a period of five years at an exercise price of \$0.01 per share. The options were issued in consideration of legal services.

In December 2014, the Company issued options to consultants to acquire 2,350,000 shares of common stock for a period of five years at an exercise price of \$0.14 per share as an incentive for continued employment with the Company.

The Company entered into Subscription Agreements with accredited investors (the "December 2014 Investors") providing for the sale by the Company to the December 2014 Investors of 14% Unsecured Convertible Promissory Notes in the aggregate amount of \$900,000 (the "December 2014 Notes"). Upon the increase of the authorized shares of common stock to 500,000,000, the December 2014 Notes automatically convert into shares of common stock. On February 11, 2015, the Company amended its certificate of incorporation to increase its authorized shares of common stock to 500,000,000. The Company is in the process of delivering the 11,678,571 shares of common stock deliverable upon automatic conversion of the December 2014 Notes. In addition to the December 2014 Notes, the December 2014 Investors also received common stock purchase warrants (the "December 2014 Warrants") to acquire 3,214,286 shares of common stock of the Company. The December 2014 Warrants are exercisable for five years at an exercise price of \$0.14. The initial closing of \$200,000 was on November 24, 2014 and the second closing of \$700,000 was on December 8, 2014. The December 2014 Notes mature one year from their respective effective dates (the "Maturity Dates") and interest associated with the December 2014 Notes is 14% per annum, which is payable on the Maturity Dates. The December 2014 Notes and the December 2014 Warrants carry standard anti-dilution provisions. Further, for a period of six months from issuance, upon the issuance of common stock or common stock equivalents at a price lower than the conversion price or the exercise price, the conversion price in the December 2014 Notes and the exercise price in the December 2014 Warrants will be reduced to such lower price.

On February 13, 2015, the Company entered into an agreement with Mr. Taylor whereby Mr. Taylor agreed to waive his right to \$187,850 in accrued fees in consideration for \$50,000 in cash upon the Company raising capital and an option, issued under the 2104 Stock Compensation Plan, to acquire 774,356 shares of common stock at an exercise price of \$0.01 per share.

On February 13, 2015, Marshall S. Cogan was engaged by AMP to serve as the Chief Investment Officer and Chairman of the Board of Directors of the Company. On February 13, 2015, the Company and Mr. Cogan entered into an Executive Employment Agreement pursuant to which he was appointed as the Chief Investment Officer in consideration of an annual salary of \$135,000. Additionally, Mr. Cogan will be eligible for annual bonuses, which shall be half of the Chief Executive Officer's bonus. As additional compensation, the Company granted Mr. Cogan options to acquire 7,500,000 shares of common stock at an exercise price of \$0.15 per share for a period of three years, which vest over a three year period in equal tranches of 2,500,000 shares on the one year, two year and three year anniversary of Mr. Cogan's employment.

Between February 26, 2015 and March 20, 2015, the Company entered into subscription agreements with seven accredited investors (the "2015 Accredited Investors") pursuant to which the 2015 Accredited Investors purchased an aggregate of 2,168,978 shares of the Company's common stock for an aggregate purchase price of \$629,003.

The offers, sales, and issuances of the securities described above were deemed to be exempt from registration under the Securities Act in reliance on Section 4(a)(2) of the Securities Act or Regulation D promulgated thereunder as transactions by an issuer not involving a public offering. The recipients of securities in each of these transactions acquired the securities for investment only and not with a view to or for sale in connection with any distribution thereof and appropriate legends were affixed to the securities issued in these transactions. Each of the recipients of securities in these transactions was an accredited or sophisticated person and had adequate access, through employment, business or other relationships, to information about us.

ITEM 6. SELECTED FINANCIAL DATA

YEARS ENDED DECEMBER 31,	2014	2013	2012
OPERATING SUMMARY			
Sales	177,500	177,500	272,098
Net loss during the development stage	(6,608,680)	(6,110,553)	(4,272,489)
Basic and diluted loss per share	(0.05)	(0.08)	(0.10)
Shares used in per share calculation	136,028,839	75,710,613	44,915,220
FINANCIAL POSITION SUMMARY			
Total assets	4,951,989	4,850,997	220,693
Cash and cash equivalents	442,257	7,019	39,819
Total current assets	909,630	443,736	93,846
Total current liabilities	3,267,235	4,464,578	2,438,540
Net working capital	(2,357,605)	(4,020,842)	(2,344,694)
Stockholders' equity (deficit)	(809,387)	(1,906,471)	(2,580,033)
Common stock outstanding	149,944,982	82,711,524	55,955,463
CASH FLOW SUMMARY			
Net cash provided (used) by operations	(4,466,588)	(2,732,628)	(2,201,281)
Net cash provided (used) by investing activities	(23,104)	(2,750,063)	(22,753)
Net cash provided (used) by financing activities	4,924,930	5,449,892	2,174,365
Net increase (decrease) in cash and equivalents	435,238	(32,799)	(49,669)

ITEM 7. MANAGEMENT'S DISCUSSION AND ANALYSIS OF FINANCIAL CONDITION AND RESULTS OF OPERATIONS

The following discussion and analysis should be read in conjunction with our consolidated financial statements and the related notes that appear elsewhere in this Annual Report on Form 10-K

Overview and 2014 Highlights

We design, develop, manufacture, and sell high-performance, medium-duty trucks with advanced powertrain components under the proven Workhorse chassis brand. We believe that our vehicles, engineering expertise, innovation, and operational structure differentiate us from traditional truck manufacturers.

AMP has entered into a purchase agreement with a major transportation company to supply 18 all-electric Workhorse E-100 Walk In Vans to be deployed in the Houston-Galveston, Texas area. The U.S. Department Of Energy (DOE) selected this project to improve local air quality in the Houston-Galveston area, which is currently designated as a National Ambient Air Quality Non-Attainment Area.

AMP's Workhorse E-100 truck is purpose-built to transform the package delivery vehicle market. Built on our new, narrow track W88 chassis, the trucks come with a 100 kWh Lithium battery pack featuring Panasonic 18650 cells that provide power to a 2200 nm (268 bhp) permanent magnet motor powerful enough to eliminate the need for a transmission.

The Workhorse E-100 is designed and built to meet the transportation company's daily duty cycle while delivering a zero-emission driving experience and eliminating the consumption of more than 650,000 gallons of diesel fuel over the vehicle's projected life. In addition, AMP's proprietary onboard telematics capture thousands of data points to measure vehicle performance and efficiency.

AMP also received orders for 2 E-Gen vehicles for the same company for testing. The first one was delivered on March 24, 2015 and the second will be delivered on March 30, 2015.

The Company responded on March 6 to a Request for Information and Prequalification (RFI) from the United States Postal Service (USPS) for its Next Generation Delivery Vehicle (NGDV) Acquisition Program. The USPS anticipates making a single award in 2017 to a supplier for up to 180,000 NGDVs to replace its current fleet of mail delivery vehicles. Delivery of the NGDVs to the USPS is expected to begin no later than January 2018. The USPS has stated that it expects to evaluate the submitted RFIs and announce a short list of OEMs in April, who will then submit detailed specifications and build several prototypes for testing. There is no guarantee that the Company will be invited to submit detailed specifications or, if it is invited, that the Company will be awarded as the supplier. The Company expects that it is competing against larger, better financed competitors.

We recently announced that we filed a provisional patent for a new system that extends the range of electric vehicles while reducing the overall cost of the typical battery-electric power train. The new system, E-GEN Drive(TM), is designed specifically for the package delivery vehicle market, in which the diesel and/or gasoline-powered vehicles in use now, stop and restart hundreds of times a day. We believe that battery-electric technology is an ideal fit for urban and suburban delivery routes and we understand fleet owner's concerns about range anxiety and cost. Our E-GEN Drive system will enable them to complete the typical route on all electric power using smaller battery packs, thus reducing the cost of the entire system. Our E-GEN Drive trucks, offer a three-year payback making them price competitive with gasoline-powered trucks.

Our E-GEN has recently been approved by the Environmental Protection Agency for on-road use. We believe this is a very significant step

towards adoption of this power train by fleet operators.

Our association with Power Solutions International (PSIX:NASDAQ) provides us with multi-fuel engines that function as generators. When the ignition is shut off, the engine automatically turns on and recharges the battery pack. When the ignition is turned back on, the engine turns off and the vehicle reverts to all-electric power. The engine and the battery-powered motor are never in use at the same time. It's not a traditional hybrid, but an emergency-range electric vehicle.

As a result, we believe our new design has many benefits, including:

- Fleet management flexibility: Depending on our customer's driving patterns and fuel cost goals, our E-GEN drive train can be remotely adjusted to use more electric power or internal combustion engine (ICE) power at their choice.
- Energy efficiency and cost of ownership: We believe our trucks offer our customers an attractive cost of ownership profile when compared to similar products. Using a single electric powertrain with a small ICE enables us to create a lighter, more energy efficient vehicle that is mechanically simple. Since we are able to use smaller battery packs, we can reduce the cost of the entire system. Additionally, government incentives can reduce the cost of ownership even further.
- High performance: We believe our trucks deliver an unparalleled driving experience with powerful acceleration for the most demanding applications with the added benefit of a very quiet operation.

We also announced the second generation, full-electric truck "E-100" which is a significant improvement to our first generation vehicle. The second-generation vehicle includes a single powerful electric motor with no transmission and new lighter, high-density Lithium Ion batteries giving the vehicle a range of up to 100 miles.

In March of 2013, we purchased the former Workhorse Custom Chassis assembly plant in Union City, Indiana from a subsidiary of Navistar International (NAV:NYSE). With this acquisition, we intend to become an Original Equipment Manufacturer (OEM) of Class 3-6 commercial-grade, medium-duty truck chassis to be marketed under the Workhorse® brand. We will need to raise significant capital in order to commence manufacturing at the Union City facility.

Ownership and operation of this plant enables us to build new chassis with gross vehicle weight capacities of between 10,000 and 26,000 pounds and offer them in four different fuel variants—electric, gas, propane, and compressed natural gas (CNG). We plan to offer commonly known Workhorse chassis like the W22, W42, W62, as well as a new, 88" track, W88 truck chassis that will be offered to fleet purchasing managers at price points that are both attractive and cost competitive.

At the same time, AMP intends to partner with engine suppliers and body fabricators to offer fleet-specific, custom, purpose-built chassis that provide total cost of ownership solutions that are superior to the competition.

In addition to having the ability to build our own chassis, we design and produce battery-electric power trains that can be installed in new Workhorse chassis for Class 3-6 medium-duty vehicles from diesel or gasoline power to electric power. Our approach is to provide battery-electric power trains utilizing proven, automotive-grade, mass-produced parts in its architecture coupled with in-house control software that we have developed over the last five years.

The Workhorse Custom Chassis acquisition includes other important assets including the Workhorse brand and logo, intellectual property, schematics, logistical support from Up-Time Parts (a Navistar subsidiary) and, perhaps most importantly, a network of 400-plus sales and service outlets across North America. We believe combination of AMP's chassis assembly capability, coupled with its ability to offer an array of fuel choices, gives AMP/Workhorse a unique opportunity in the marketplace.

Our unique HorseFly line of drones is designed to be the 'last mile' solution in delivery logistics. We worked with the University of Cincinnati to develop the HorseFly to meet the rigors of package delivery and to have eight rotors and redundant systems to ensure safety in the air. Today, we estimate that it costs approximately \$1 to move a 20,000-pound diesel-powered truck one mile. While we believe our Workhorse trucks can reduce the standard delivery costs from \$1 to less than \$0.30 cents per mile based on current costs of fuel, we expect that having drones handle the last leg of delivery could further potentially reduce the cost to about \$.03 cents for the last mile. The all weather HorseFly battery-powered drone will carry up to 10 pounds of cargo with a 15-mile range. It is designed to meet the anticipated FAA drone guidelines expected in 2015, of which there is no guarantee, and is differentiated from other drones as it is designed to work in tandem with a Workhorse electric truck. HorseFly will deliver packages, loaded on-route by the truck's driver, to remote locations while the driver continues on the main delivery route. HorseFly will then rejoin the truck at its new location after its delivery is completed, saving the fleet operator much of the time and fuel cost of the last, most expensive, mile. Also while the HorseFly is atop the Workhorse truck, it can quickly charge its batteries from the truck's large battery pack. We believe this implementation is superior to the proposed deployment of other delivery drones wherein the package is loaded at a distant warehouse and the drone must make a round trip flight to the delivery address and back to the warehouse. Other applications for the HorseFly include transmission line inspections and agricultural surveys.

Results of Operations

Our condensed consolidated statement of operations data for the period presented follows:

	<u>2014</u>	<u>2013</u>
Sales	\$ 177,500	\$ 177,500
Operating Expenses		
Selling, general and administrative	2,950,467	3,137,288
Research and development	<u>3,436,751</u>	<u>2,892,505</u>
Total operating expenses	6,387,218	6,029,793
Interest expense, net	<u>398,963</u>	<u>258,261</u>
Net loss	<u>\$ (6,608,680)</u>	<u>\$ (6,110,554)</u>

Revenue

We generated revenue of \$177 thousand for year ended December 31, 2014 for the delivery of an all-electric Para-transit 12 passenger bus to BARTA (Berks County Regional Transit Authority) of Pennsylvania. We generated revenue of \$177 thousand for the year ended December 31, 2013 for half of the order to BARTA delivered during 2013. Direct Costs charged to operations were \$177 thousand for the years ended December 31, 2014 and 2013.

We have received several orders from fleets which we are in the process of filling and that we expect to deliver in the next 12 months.

Selling, General and Administrative Expenses

Selling, general and administrative expenses consist primarily of personnel and facilities costs related to our development including, marketing, sales, executive, finance, human resources, information technology and professional, legal and contract services.

Selling, general and administrative expenses during the years ended December 31, 2014 and 2013 were \$2.9 million and \$3.1 million, respectively. The \$186 thousand decrease is mainly due to a reduction in stock based compensation.

Research and Development Expenses

Research and development expenses consist primarily of personnel costs for our teams in engineering and research, prototyping expense, and contract and professional services. Union City plant expenses prior to the start of production are also included in research and development expenses.

Research and development expenses during the years ended in December 31, 2014 and 2013 were approximately \$3.4 million and \$2.9 million respectively. The \$544 thousand increase is the result of higher engineering consulting expense as well as increments in motors and batteries for E-Gen prototypes.

Interest Expenses

Our interest expense is incurred primarily from our long term loan with Navistar in connection to the purchase of the Union City plant mentioned before in the Property, Plant and Equipment and Long Term Loan notes to the financial statements.

Interest expenses during the year ended in December 31, 2014 and 2013 were approximately \$399 thousand and \$258 thousand, respectively, an increase of \$141 thousand mainly due to higher principal on the Navistar loan after capitalization of the first year interests and commissions on the notes payable mentioned on Note 4 of the financial statements.

Liquidity and Capital Resources

Summary of Cash Flows

	<u>2014</u>	<u>2013</u>
Net cash used in operating activities	(4,466,588)	(2,732,628)
Net cash used in investing activities	(23,104)	(2,750,063)
Net cash provided by financing activities	4,924,930	5,449,892

Cash Flows from Operating Activities

Our cash flows from operating activities are affected by our cash investments to support the business in research and development, manufacturing, selling, general and administrative. Our operating cash flows are also affected by our working capital needs to support fluctuations in inventory, personnel expenses, accounts payable and other current assets and liabilities.

Net cash used in operating activities was \$4.5 million during the year ended December 31, 2014. The largest component of our cash used during this was to our net loss of \$6.6 million, which included non-cash charges such as depreciation of \$388 thousand, stock based compensation of \$400 thousand, consulting services paid in stock of \$932 thousand, interest paid in kind of \$225 thousand on the Navistar long term loan. Operating cash outflows for the year ended December 31, 2014 were primarily related to research and development expenses of \$3.4 million and operating expenses of \$3.2 million.

Net cash used in operating activities was \$2.7 million during the year ended December 31, 2013. The main component of our cash used during this periods related to our net loss of \$6.1 million, which included non-cash charges such as depreciation of \$319 thousand, stock based compensation of \$1.4 million and consulting services paid in stock of \$1.1 million. Operating cash outflows for the year ended December 31, 2013 were primarily related to research and development expenses of \$2.2 million and operating expenses of \$2.5 million, partially offset by \$142 thousand increase in customer deposits and \$156 thousand in accounts payable.

Cash Flows from Investing Activities

Cash flow from investing activities primarily relates to capital expenditures to support our future growth in operations including the investments made in the Union City plant.

There was \$23 thousand of cash used in investing activities during the year ended December 31, 2014. The \$2.7 million used during the year ended in December 31, 2013 were mainly invested in the Union City Plant purchase.

Cash Flows from Financing Activities

Net cash provided by financing activities was \$4.9 million during the year ended December 31, 2014 and was comprised primarily of \$5.9 million issuance of stock offset by the capitalization of shareholders' advances of \$1.6 million for a net of \$4.3 million and proceeds from notes payable of \$1.2 million, offset by payments of \$326 thousand for long term debt, and repayment of shareholders' advances of \$285 thousand.

Net cash provided by financing activities was \$5.4 million during the year ended December 31, 2013 and was comprised primarily of \$4.3 million of issuance of common stock and the receipt of shareholder advances of \$1.4 million.

Credit Facility

Presently we have no revolving Credit Facility established. There is no guarantee that we will be able to enter into an agreement to establish a line of credit or that if we do enter into such agreement that it will be on favorable terms.

Off-Balance Sheet Arrangements

The Company does not have any off-balance sheet arrangements that have or are reasonably likely to have a current or future effect on the Company's financial condition, changes in financial condition, revenues or expenses, results of operations, liquidity, capital expenditures or capital resources that are material to investors.

Federal Tax Credit Qualification by the IRS

The Company has been qualified by the IRS for a vehicle federal tax credit of up to \$7,500. The Company joins a list of plug-in electric drive motor vehicle manufacturers, including Ford Motor Company, General Motors Corporation, Tesla, Toyota, and 13 EV manufacturers in all, qualifying purchasers for up to a \$7,500 tax credit when purchasing an electric vehicle.

Additionally, many states offer additional sales tax exemptions and zero emission tax credits of up to \$5,000 that can also be applied to the purchase.

California Air Resources Board Approval

On February 20, 2013 the California Air Resource Board (CARB) approved the medium to heavy duty AMP commercial truck for sale in the state of California. Most other states use this approval for sale of vehicles in their state.

Critical Accounting Policies and Estimates

The following accounting principles and practices of AMP are set forth to facilitate the understanding of data presented in the consolidated financial statements:

Nature of operations

A development stage company, AMP is a technology-driven business that plans to deliver a full-performance, all electric, powertrain for medium duty commercial vehicles. Operating with three specific approaches, AMP converts existing internal combustion engine based vehicles to all electric powertrains, provides original equipment manufacturers (OEM's) with AMP designed and integrated modular electric components, and provides electric powertrain engineering to end-users. AMP has not recorded significant revenue since inception in February 2007, and is developing its operations through a sale, design and manufacturing facility located near Cincinnati, Ohio.

Use of estimates

The preparation of financial statements in conformity with accounting principles generally accepted in the United States of America requires management to make estimates and assumptions that affect certain reported amounts and disclosures. Accordingly, actual results could differ from those estimates.

Property and depreciation

Property and equipment is recorded at cost. Depreciation is provided on the straight-line and accelerated methods over the estimated useful lives of the respective assets.

Income taxes

With the consent of its shareholders, at the date of inception, AMP elected under the Internal Revenue Code to be taxed as an S corporation. Since shareholders of an S corporation are taxed on their proportionate share of the Company's taxable income, an S corporation is generally not subject to either federal or state income taxes at the corporate level. On December 28, 2009 pursuant to the merger transaction the company revoked its election to be taxed as an S-corporation.

As no taxable income has occurred from the date of this merger to December 31, 2014 cumulative deferred tax assets of approximately \$8.5 million are fully reserved, and no provision or liability for federal or state income taxes has been included in the financial statements. Carryover amounts are:

Approximate net operating loss (\$ millions)	Carryover to be used against taxable income generated through year
3.6	2030
6.7	2031
3.9	2032
4.7	2033
6.1	2034

Research and development costs

Research and development costs are expensed as they are incurred. Research and development expense incurred was approximately \$3.4 million and \$2.9 million for the years ended December 31, 2014 and 2013, respectively, and \$16.4 million for the period from inception to December 31, 2014 consisting of consulting, payroll and payroll taxes, engineering temporaries, purchased supplies, legal fees, parts and small tools.

ITEM 7A. QUANTITATIVE AND QUALITATIVE DISCLOSURES ABOUT MARKET RISK

As a smaller reporting company, we are not required to include disclosure under this item.

ITEM 8. FINANCIAL STATEMENTS AND SUPPLEMENTARY DATA

TABLE OF CONTENTS

Report of Independent Registered Public Accounting Firm	F-2
Financial Statements:	
Balance Sheets	F-3
Statements of Operations	F-4
Statements of Stockholders' Equity	F-5
Statements of Cash Flows	F-6
Notes to Financial Statement	F-7

REPORT OF INDEPENDENT REGISTERED PUBLIC ACCOUNTING FIRM

Board of Directors and Stockholders
AMP Holding Inc. (A Developing Stage Company)
Cincinnati, Ohio

We have audited the accompanying balance sheets of AMP Holding Inc. (A Development Stage Company) as of December 31, 2014 and 2013 and the related statements of operations, stockholders' equity (deficit), and cash flows for the years then ended and for the period from inception, February 20, 2007, to December 31, 2014. These financial statements are the responsibility of the company's management. Our responsibility is to express an opinion on these financial statements based on our audits.

We conducted our audits in accordance with the standards of the Public Company Accounting Oversight Board (United States). Those standards require that we plan and perform the audit to obtain reasonable assurance about whether the financial statements are free of material misstatement. The company is not required to have, nor were we engaged to perform, an audit of its internal control over financial reporting. Our audit included consideration of internal control over financial reporting as a basis for designing audit procedures that are appropriate in the circumstances, but not for the purpose of expressing an opinion on the effectiveness of the company's internal control over financial reporting. Accordingly, we express no such opinion. An audit also includes examining, on a test basis, evidence supporting the amounts and disclosures in the financial statements, assessing the accounting principles used and significant estimates made by management, as well as evaluating the overall financial statement presentation. We believe that our audits provide a reasonable basis for our opinion.

In our opinion, the financial statements referred to above present fairly, in all material respects, the financial position of AMP Holding Inc. as of December 31, 2014 and 2013, and the results of its operations and its cash flows for the years then ended and for the period from inception, February 20, 2007, to December 31, 2014 in conformity with accounting principles generally accepted in the United States of America.

The accompanying financial statements have been prepared assuming the Company will continue as a going concern. As described in Note 1, the Company has not had significant sales and has negative working capital and stockholders' deficits, which raise substantial doubt about its ability to continue as a going concern. Management's plan in regard to this matter is also discussed in Note 1. The financial statements do not include any adjustments that might result from the outcome of these uncertainties.

Clark, Schaefer, Hackett & Co.

Cincinnati, Ohio
March 27, 2015

1 east fourth street, suite 1200
cincinnati, ohio 45202

www.cshco.com
p. 513.241.3111
f. 513.241.1212

cincinnati | columbus | cleveland | miami valley | springfield | toledo

AMP Holding Inc.
(A Development Stage Company)
Consolidated Balance Sheets
December, 31 2014 and 2013

	December 31, 2014	December 31, 2013
Assets		
Current assets:		
Cash and cash equivalents	\$ 442,257	\$ 7,019
Inventory	392,750	392,750
Prepaid expenses and deposits	74,623	43,967
	909,630	443,736
Property, plant and equipment, net	4,042,359	4,407,261
	\$ 4,951,989	\$ 4,850,997
Liabilities and Stockholders' Equity (Deficit)		
Current liabilities:		
Accounts payable	\$ 1,603,555	\$ 1,546,388
Accounts payable, related parties	384,776	468,165
Customer deposits	-	177,500
Notes payable	1,243,000	
Shareholder advances	-	1,934,300
Current portion of long-term debt	35,904	338,225
	\$ 3,267,235	\$ 4,464,578
Long-term debt	2,494,141	2,292,890
Stockholders' equity (deficit):		
Series A preferred stock, par value of \$.001 per share 75,000,000 shares shares authorized, 0 shares issued and outstanding at December 31, 2014 and December 31, 2013		-
Common stock, par value of \$.001 per share 250,000,000 shares authorized, 149,944,892 shares issued and outstanding at December 31, 2014 and 82,711,524 shares issued and outstanding at December 31, 2013	149,937	82,712
Additional paid-in capital	27,128,582	20,321,536
Stock based compensation	6,002,586	5,171,093
Accumulated deficit during the development stage	(34,090,492)	(27,481,812)
	(809,387)	(1,906,471)
	\$ 4,951,989	\$ 4,850,997

See accompanying notes to financial statements.

AMP Holding Inc.
(A Development Stage Company)
Consolidated Statements of Operations
For the Years Ended December 31, 2014 and 2013
and for the Period From Inception
February 20, 2007 to December 31, 2014
(Unaudited)

	2014	2013	Since Date of Inception, February 20, 2007 to December 31, 2014
Sales	\$ 177,500	\$ 177,500	\$ 957,840
Operating Expenses			
Selling, general and administrative	2,950,467	3,137,288	17,696,441
Research and development	3,436,751	2,892,505	16,437,341
Total operating expenses	<u>6,387,218</u>	<u>6,029,793</u>	<u>34,133,782</u>
Interest expense, net	<u>398,963</u>	<u>258,261</u>	<u>914,551</u>
Net loss during the development stage	<u>\$ (6,608,680)</u>	<u>\$ (6,110,554)</u>	<u>\$ (34,090,492)</u>
Basic and diluted loss per share	<u>\$ (0.05)</u>	<u>\$ (0.08)</u>	
Weighted average number of common shares outstanding	<u>136,028,839</u>	<u>75,710,613</u>	

See accompanying notes to financial statements.

receivable	168,210	753,511	-	-	49,989	-	-	803,500
Share based compensation to								
December 28, 2009	-	7,983	-	-	-	-	-	7,983
Shares issued out of stock option plan on								
December 31, 2009	3,220	-	-	-	-	-	-	-
Net effect of purchase accounting adjustments	17,508,759	(2,528,479)	-	-	2,528,479	-	-	-
Conversion of convertible notes	-	-	8,375	8	264,992	-	-	265,000
Net loss from operations for the year ended								
December 31, 2009	-	-	-	-	-	-	(1,524,923)	(1,524,923)
	<u>17,772,449</u>	<u>\$ 17,772</u>	<u>8,375</u>	<u>\$ 8</u>	<u>\$ 2,843,460</u>	<u>\$ -</u>	<u>\$ (3,364,952)</u>	<u>\$ (503,712)</u>

Conversion of convertible note	29,750	30	-	-	9,970	-	-	10,000
Issuance of preferred stock, and fulfillment of stock subscriptions receivable	-	-	625	1	24,999	-	-	25,000
Issuance of common stock, and fulfillment of stock subscriptions receivable	9,808,566	9,809	-	-	3,682,530	-	-	3,692,339
Conversion of account payable	101,636	102	-	-	86,898	-	-	87,000
Share based compensation for the year ended								
December 31, 2010	-	-	-	-	-	1,436,979	-	1,436,979
Net loss from operations for the year ended								
December 31, 2010	-	-	-	-	-	-	(5,028,106)	(5,028,106)
	<u>27,712,401</u>	<u>\$ 27,713</u>	<u>9,000</u>	<u>\$ 9</u>	<u>\$ 6,647,857</u>	<u>\$ 1,436,979</u>	<u>\$ (8,393,058)</u>	<u>\$ (280,500)</u>

Issuance of common stock, and fulfillment of stock subscriptions receivable	9,912,447	9,911	-	-	5,404,830	-	-	5,414,741
Stock options and warrants exercised	38,692	39	-	-	12,236	-	-	12,275
Conversion								

of preferred stock to common stock	1,071,110	1,072	(9,000)	(9)	(1,063)	-	-	-
Share based compensation for the year ended December 31, 2011	-	-	-	-	-	2,002,891	-	2,002,891
Net loss from operations for the year ended December 31, 2011	-	-	-	-	-	-	(8,705,711)	(8,705,711)
	<u>38,734,650</u>	<u>\$ 38,735</u>	<u>-</u>	<u>\$ -</u>	<u>\$ 12,063,860</u>	<u>\$ 3,439,870</u>	<u>\$ (17,098,769)</u>	<u>\$ (1,556,304)</u>
Issuance of detached warrants in connection with convertible debentures	-	-	-	-	91,493	-	-	91,493
Conversion of debentures and interest	10,227,070	10,227	-	-	2,035,187	-	-	2,045,414
Conversion of account payable	6,993,743	6,993	-	-	766,007	-	-	773,000
Share based compensation for the year ended December 31, 2012	-	-	-	-	-	338,853	-	338,853
Net loss from operations for the year ended December 31, 2012	-	-	-	-	-	-	(4,272,489)	(4,272,489)
	<u>55,955,463</u>	<u>\$ 55,955</u>	<u>-</u>	<u>\$ -</u>	<u>\$ 14,956,547</u>	<u>\$ 3,778,723</u>	<u>\$ (21,371,258)</u>	<u>\$ (2,580,033)</u>
Issuance of common stock, and fulfillment of stock subscriptions receivable	21,330,000	21,330	-	-	4,254,270	-	-	4,275,600
Stock options and warrants exercised	18,764	20	-	-	1,143	-	-	1,163
Conversion of convertible note	500,000	500	-	-	99,500	-	-	100,000
Conversion of account payable	4,907,297	4,907	-	-	1,010,076	-	-	1,014,983
Share based compensation for the year ended December 31, 2013	-	-	-	-	-	1,392,370	-	1,392,370
Net loss from operations for the year ended December 31, 2013	-	-	-	-	-	-	(6,110,554)	(6,110,554)

Issuance of common stock, and fulfillment of stock subscriptions receivable	82,711,524	\$ 82,712	-	\$ -	\$ 20,321,536	\$ 5,171,093	\$ (27,481,812)	\$ (1,906,471)
Stock options and warrants exercised	59,423,000	59,423	-	-	5,882,877	-	-	5,942,300
Conversion of account payable	7,810,458	7,802	-	-	924,169	-	-	931,973
Share based compensation for the year ended December 31, 2014	-	-	-	-	-	831,493	-	831,493
Net loss from operations for the year ended December 31, 2014	-	-	-	-	-	-	(6,608,680)	(6,608,680)
	<u>149,944,982</u>	<u>149,937</u>	<u>-</u>	<u>-</u>	<u>27,128,582</u>	<u>6,002,586</u>	<u>(34,090,492)</u>	<u>(809,387)</u>

See accompanying notes to financial statements

AMP Holding Inc.
(A Development Stage Company)
Consolidated Statements of Cash Flows
For the Years Ended December 31, 2014 and 2013
and for the Period From Inception
February 20, 2007 to December 31, 2014

	2014	2013	Since Date of Inception, February 20, 2007 to December 31, 2014
Cash flows from operating activities:			
Net loss during the development stage	\$ (6,608,680)	\$ (6,110,554)	\$(34,090,492)
Adjustments to reconcile net loss from operations to cash used by operations:			
Depreciation	388,006	319,649	1,000,662
Loss on sale of assets	-	-	27,544
Stock based compensation	414,597	1,392,370	5,603,403
Interest expense on convertible debentures	13,269	52,795	172,228
Amortized discount on convertible debentures	-	-	91,493
Legal, consulting and investment services	931,973	1,106,328	2,948,301
Interest paid in kind	225,000	-	225,000
Effects of changes in operating assets and liabilities:			
Inventory	-	48,252	7,250
Prepaid expenses and deposits	(30,656)	(30,942)	(74,624)
Accounts payable	460,794	293,160	2,520,818
Accounts payable, related parties	(83,389)	78,814	331,981
Customer deposits	(177,500)	117,500	-
Net cash used by operations	<u>(4,466,588)</u>	<u>(2,732,628)</u>	<u>(21,236,411)</u>
Cash flows from investing activities:			
Cash paid in acquisition of Workhorse Custom Chasis, LLC	-	(2,750,000)	(2,750,000)
Capital expenditures	(23,104)	(63)	(399,817)
Proceeds on sale of assets	-	-	38,900
Net cash used by investing activities	<u>(23,104)</u>	<u>(2,750,063)</u>	<u>(3,110,917)</u>
Cash flows from financing activities:			
Proceeds from debentures	-	-	1,939,250
Proceeds from notes payable	1,243,000	-	1,403,000
Payments on notes payable	-	-	(150,000)
Proceeds from long-term debt	-	-	50,000
Payments on long-term debt	(326,070)	(211,826)	(556,954)
Conversion of note payable	-	-	-
Shareholder advances, net of repayments	(285,000)	1,376,300	1,649,300
Issuance of common and preferred stock	4,293,000	4,285,418	20,454,989
Net cash provided by financing activities	<u>4,924,930</u>	<u>5,449,892</u>	<u>24,789,585</u>
Change in cash and cash equivalents	435,238	(32,799)	442,257
Cash at the beginning of the period	7,019	39,819	-
Cash at the end of the period	<u>442,257</u>	<u>7,020</u>	<u>442,257</u>

Supplemental disclosure of non-cash activities:

Vehicles valued at \$61,284 were contributed as consideration for issuance of common stock in February 2007.

Consulting services valued at \$50,000 were accepted as consideration for issuance of common stock in October 2008.

During March 2010 a note payable of \$10,000 was converted to 29,750 shares of common stock.

A vehicle valued at \$33,427 was acquired through bank financing in September 2010.

Consulting services valued at \$87,000 were accepted as consideration for issuance of common stock in December 2010.

Equipment valued at \$14,937 was acquired through debt financing in December 2011.

Consulting services valued at \$60,000, \$55,000, and \$203,000 were accepted as consideration for issuance of common stock in March, October, and December 2012, respectively.

Detachable warrants associated with convertible debentures valued at \$91,493 were recorded as increases to additional paid-in capital from January to August 2012.
Investment Agreement fees valued at \$375,000 were accepted as consideration for issuance of common stock in August 2012.
Legal services valued at \$40,000, \$15,000, and \$25,000 were accepted as consideration for issuance of common stock in September, November, and December 2012, respectively.
During November 2012 debentures for \$1,939,250 and interest of \$106,164 were converted to 10,227,070 shares of common stock.
During December 2012 accounts payable of \$513,636 were converted to notes payable.
During February 2013 a note payable of \$100,000 was converted to 500,000 shares of common stock.
During March 2013, the Company entered into a note payable in the amount of \$2,250,000 related to the acquisition of Workhorse Custom Chassis, LLC. See note 2 to the financial statements.
Consulting services valued at \$302,500, \$126,000, \$119,075, \$11,750, and \$155,000 were accepted as consideration for issuance of common stock in March, May, June, July, and September 2013, respectively.
Legal services valued at \$40,000, \$15,000, \$5,000, and \$5,000 were accepted as consideration for issuance of common stock in March, June, July, and August 2013, respectively.
Rent expense valued at \$80,190 was accepted as consideration for issuance of common stock in March, June, July, and August 2013, respectively.
Accounts payable source for the year ended December 2014 includes \$416,896 of payroll expenses paid with stock options.
Issuance of common and preferred stock for the year ended December 2014 includes the capitalization of shareholders' advances of \$1,649,300.

AMP Holding Inc.

Notes to Consolidated Financial Statements (Unaudited)

1. SUMMARY OF SIGNIFICANT ACCOUNTING PRINCIPLES

The following accounting principles and practices are set forth to facilitate the understanding of data presented in the financial statements:

Nature of operations and principles of consolidation

AMP Holding Inc. (AMP, we, us or our) designs, develops, manufacture, and sells high-performance, medium-duty trucks with advanced powertrain components under the Workhorse chassis brand.

AMP Holding Inc., formerly known as Title Starts Online, Inc. (the Company), incorporated in the State of Nevada in 2007 with \$3,100 of capital from the issuance of common shares to the founding shareholder. On August 11, 2008 the Company received a Notice of Effectiveness from the U.S. Securities and Exchange Commission, and on September 18, 2008, the Company closed a public offering in which it accepted subscriptions for an aggregate of 200,000 shares of its common stock, raising \$50,000 less offering costs of \$46,234. With this limited capital the Company did not commence operations and remained a “shell company” (as defined in Rule 12b-2 under the Securities Exchange Act of 1934, as amended).

On December 28, 2009, the Company entered into and closed a Share Exchange Agreement with the Shareholders of Advanced Mechanical Products, Inc. (n/k/a AMP Electric Vehicles, Inc.) (AMP) pursuant to which the Company acquired 100% of the outstanding securities of AMP in exchange for 14,890,904 shares of the Company's common stock. Considering that, following the merger, the AMP Shareholders control the majority of the outstanding voting common stock of the Company, and effectively succeeded the Company's otherwise minimal operations to those that are AMP. AMP is considered the accounting acquirer in this reverse-merger transaction. A reverse-merger transaction is considered and accounted for as a capital transaction in substance; it is equivalent to the issuance of AMP securities for net monetary assets of the Company, which are de minimis, accompanied by a recapitalization. Accordingly, goodwill or other intangible assets have not been recognized in connection with this reverse merger transaction. AMP is the surviving entity and the historical financials following the reverse merger transaction will be those of AMP. The Company was a shell company immediately prior to the acquisition of AMP pursuant to the terms of the Share Exchange Agreement. As a result of such acquisition, the Company operations are now focused on the design, marketing and sale of modified vehicles with an all-electric power train and battery systems. Consequently, we believe that acquisition has caused the Company to cease to be a shell company as it now has operations. The Company formally changed its name to AMP Holding Inc. on May 24, 2010.

Since the acquisition, the Company has devoted the majority of its resources to the development of an all-electric drive system capable of moving heavy large vehicles ranging from full size SUV's up to and including Medium Duty Commercial trucks. Additionally, in February 2013, AMP Holding Inc. formed a new wholly owned subsidiary, AMP Trucks Inc., an Indiana corporation. On March 13, 2013 AMP Trucks Inc. closed on the acquisition of an asset purchase of Workhorse Custom Chassis, LLC. The assets included in this transaction included: the Workhorse brand, access to the dealer network of 440 dealers nationwide, intellectual property, and all physical assets which included the approximately 250,000 sq. ft. of facilities on 48 acres of land in Union City, Indiana. This acquisition allows AMP Holding Inc. to position itself as a medium duty OEM capable of producing new chassis with electric, propane, compressed natural gas, and hybrid configurations, as well as gasoline drive systems. Revenues since the inception of the Company, February 20, 2007, through the date of these financial statements have not been significant and consist of customer vehicle conversions and sales of converted experimental vehicles.

Development-stage Company

Based on the Company's business plan, it is a development stage company since planned principal operations resulting in revenue have not fully commenced. Accordingly, the Company presents its financial statements in conformity with the accounting principles generally accepted in the United States of America that apply to developing enterprises. As a development stage enterprise, the Company discloses its retained earnings (or deficit accumulated) during the development stage and the cumulative statements of operations and cash flows from commencement of development stage to the current balance sheet date. The development stage began in 2007 when the Company was organized.

Basis of presentation

The financial statements have been prepared on a going concern basis, which contemplates the realization of assets and liquidation of liabilities in the normal course of business. However, the Company has limited revenues and has negative working capital and stockholders' deficits. These conditions raise substantial doubt about the ability of the Company to continue as a going concern.

In view of these matters, continuation as a going concern is dependent upon the continued operations of the Company, which in turn is dependent upon the Company's ability to meet its financial requirements, raise additional capital, and the success of its future operations. The financial statements do not include any adjustments to the amount and classification of assets and liabilities that may be necessary should the Company not continue as a going concern.

The Company has continued to raise capital. Management believes the proceeds from these offerings, future offerings, and the Company's anticipated revenue provides an opportunity to continue as a going concern. If additional funding is required, the Company plans to obtain working capital from either debt or equity financing from the sale of common, preferred stock, and/or convertible debentures. Obtaining such working capital is not assured.

The preparation of financial statements in conformity with generally accepted accounting principles requires management to make estimates and assumptions that affect the amounts reported in the financial statements and accompanying notes. Actual results could differ from these estimates.

Certain reclassifications were made to the prior year financial statements to conform to the current year presentation. These reclassifications had no effect on previously reported results of operation or stockholders' equity (deficit).

Financial instruments

The carrying amounts of financial instruments including cash, inventory, accounts payable and short-term debt approximate fair value because of the relatively short maturity of these instruments.

Inventory

Inventory is stated at the lower of cost or market.

Property and depreciation

Property and equipment is recorded at cost. Major renewals and improvements are capitalized while replacements, maintenance and repairs, which do not improve or extend the lives of the respective assets, are expensed. When property and equipment is retired or otherwise disposed of, a gain or loss is realized for the difference between the net book value of the asset and the proceeds realized thereon. Depreciation is calculated using the straight-line method, based upon the following estimated useful lives:

- Buildings: 15 - 30 years
- Leasehold improvements: 7 years
- Software: 3 - 6 years
- Equipment: 5 years
- Vehicles and prototypes: 3 - 5 years

Capital stock

On April 22, 2010, the directors of the Company approved a forward stock split of the common stock of the Company on a 14:1 basis. On May 12, 2010, the stockholders of the Company voted to approve the amendment of the certificate of incorporation resulting in a decrease of the number of shares of Common stock. The Company filed a 14c definitive information statement with the Securities and Exchange Commission and mailed the same to its shareholders. Management filed the certificate of amendment decreasing the authorized shares of common stock with the State of Nevada on September 8, 2010.

The capital stock of the Company is as follows:

Preferred Stock - The Company has authorized 75,000,000 shares of preferred stock with a par value of \$.001 per share. These shares may be issued in series with such rights and preferences as may be determined by the Board of Directors. The Series A Stock is convertible, at any time at the option of the holder, into common shares of the Company based on a conversion price of \$0.336 per share. The holders of the Series A Stock are not entitled to convert the Series A Stock and receive shares of common stock such that the number of shares of common stock held by them in the aggregate and their affiliates after such conversion or exercise does not exceed 4.99% of the then issued and outstanding shares of common stock. The Series A Stock has voting rights on an as converted basis, does not pay dividends, and does not provide any liquidation rights.

Common Stock - The Company has authorized 250,000,000 shares of common stock with a par value of \$.001 per share.

Revenue recognition / customer deposits

It is the Company's policy that revenues will be recognized in accordance with SEC Staff Bulletin (SAB) No. 104, "Revenue Recognition". Under SAB 104, product revenues (or service revenues) are recognized when persuasive evidence of an arrangement exists, delivery has occurred (or service has been performed), the sales price is fixed and determinable, and collectability is reasonably assured. Customer deposits include monies from customers to reserve a production slot for conversion of an OEM power train to the AMP all electric power train. The final retail price and delivery date are yet to be determined. Customer deposits are subject to a full refund at the request of the customer.

Income taxes

With the consent of its shareholders, at the date of inception, AMP elected under the Internal Revenue Code to be taxed as an S corporation. Since shareholders of an S corporation are taxed on their proportionate share of the Company's taxable income, an S corporation is generally not subject to either federal or state income taxes at the corporate level. On December 28, 2009 pursuant to the merger transaction the Company revoked its election to be taxed as an S-corporation.

As no taxable income has occurred from the date of this merger to December 31, 2014 cumulative deferred tax assets of approximately \$8.5 million are fully reserved, and no provision or liability for federal or state income taxes has been included in the financial statements. Carryover amounts are:

Approximate net operating loss (\$ millions)	Carryover to be used against taxable income generated through year
3.6	2030
6.7	2031
3.9	2032
4.7	2033
6.1	2034

Uncertain tax positions

The Company adopted the provisions of Accounting for Uncertainty in Income Taxes. Those provisions clarify the accounting and recognition for income tax positions taken or expected to be taken in the Company's income tax returns. The Company's income tax filings are subject to audit by various taxing authorities. The years of filings open to these authorities and available for audit are 2011 - 2013. The Company's policy with regard to interest and penalties is to recognize interest through interest expense and penalties through other expense. No interest or penalties with regard to income tax filings were incurred in any period, including 2014 or 2013, or since the period of inception, February 20, 2007. In evaluating the Company's tax provisions and accruals, future taxable income, and the reversal of temporary differences, interpretations and tax planning strategies are considered. The Company believes their estimates are appropriate based on current facts and circumstances.

Research and development costs

The Company expenses research and development costs as they are incurred. Research and Development costs were approximately \$3.4 million and \$2.9 million for the years ended December 31, 2014 and 2013, and \$16.4 million for the period of inception to December 31, 2014, consisting primarily of personnel costs for our teams in engineering and research, prototyping expense, and contract and professional services. Union City plant expenses prior to the start of production are also included in research and development expenses.

Basic and diluted loss per share

Basic loss per share is computed by dividing net loss available to common shareholders (numerator) by the weighted average number of shares outstanding (denominator) during the period. For all periods, all of the Company's common stock equivalents were excluded from the calculation of diluted loss per common share because they were anti-dilutive, due to the Company's net losses.

Stock based compensation

The Company accounts for its stock based compensation in accordance with "Share-Based Payments" (codified in FASB ASC Topic 718 and 505). The Company recognizes in its statement of operations the grant-date fair value of stock options and warrants issued to employees and non-employees. The fair value is estimated on the date of grant using a lattice-based valuation model that uses assumptions concerning expected volatility, expected term, and the expected risk-free rate of return. For the awards granted, the expected volatility was estimated by management as 50% based on a range of forecasted results. The expected term of the awards granted was assumed to be the contract life of the option or warrant (one, two, three, five or ten years as determined in the specific arrangement). The risk-free rate of return was based on market yields in effect on the date of each grant for United States Treasury debt securities with a maturity equal to the expected term of the award.

Related party transactions

Certain stockholders and stockholder family members have advanced funds or performed services for the Company. These services are believed to be at market rates for similar services from non-related parties. Related party accounts payable are segregated in the balance sheet.

Subsequent events

The Company evaluates events and transactions occurring subsequent to the date of the consolidated financial statements for matters requiring recognition or disclosure in the consolidated financial statements. The accompanying consolidated financial statements consider events through March 27, 2015, the date on which the consolidated financial statements were available to be issued.

2. PROPERTY, PLANT AND EQUIPMENT

As of December 31, 2014 and December 31, 2013, our property, plant and equipment, net, consisted of the following:

	December 31, 2014	December 31, 2013
Land	300,000	300,000
Buildings	3,800,000	3,800,000
Leasehold Improvements	19,225	19,225
Construction in progress	23,104	-
Software	27,721	27,721
Equipment	670,183	670,183
Vehicles and prototypes	164,959	164,959
	<u>5,005,192</u>	<u>4,982,088</u>
Less accumulated depreciation	<u>(962,833)</u>	<u>(574,827)</u>
	<u><u>4,042,359</u></u>	<u><u>4,407,261</u></u>

On March 13, 2013 the Company acquired the operating assets of Workhorse Custom Chassis, LLC, an unrelated company located in Union City, Indiana. The following summarizes the consideration paid, and the components of the purchase price and the related allocation of assets acquired and liabilities assumed.

<u>Consideration</u>	
Cash at closing	\$ 2,750,000
Secured debenture	<u>2,250,000</u>
	<u><u>\$ 5,000,000</u></u>
<u>Assets acquired</u>	
Inventory	\$ 400,000
Equipment	500,000
Land	300,000
Buildings	3,800,000
	<u><u>\$ 5,000,000</u></u>

Valuation methods used for the identifiable assets acquired in the acquisition make use of fair value measurements based on unobservable inputs and reliance on management's assumptions that similar market participants would use in pricing the assets. As such, the fair value measurements represent a Level 3 input.

3. LONG-TERM DEBT

Long-term debt consists of the following:

	December 31, 2014	December 31, 2013
Secured debenture payable to Workhorse Custom Chassis, LLC, due March 2016 plus interest at 10%. The debenture is secured by the real estate and related assets of the plant located in Union City, Indiana with a net book value of \$3,981,676 at December 31, 2014	2,475,000	2,250,000
Note payable, Bank due in monthly installments of \$635 including interest at 5.04% with the final payment due August 2015. The note is secured by equipment with a net book value of \$4,463 at December 31, 2014	4,711	11,928
Note payable, vendor due in monthly installments of \$439 including interest at 8.00% with the final payment due January 2015. The note is secured by equipment with a net book value of \$5,787 at December 31, 2014	334	5,051
Note payable to the City of Loveland, due in annual installments of \$10,241 including interest with the final payment due October 2016. Interest rate amended to 8.00%. The note is unsecured and contains restrictions on the use of proceeds.	50,000	50,000
Note payable, vendor due in monthly installments of \$5,000 for the first half of 2013. Note paid on March 2014.	-	123,736
Note payable, vendor due in monthly installments of \$2,000 plus interest at 4% for the first half of 2013, escalating to final payment of \$18,461 plus interest at 4% in December 2014. Note paid on May 2014.	-	190,400
	<u>2,530,045</u>	<u>2,631,115</u>
Less current portion	<u>35,904</u>	<u>338,225</u>
Long term debt	<u><u>2,494,141</u></u>	<u><u>2,292,890</u></u>

Aggregate maturities of long-term debt are as follows:

2015	35,904
2016	19,141
2017	2,475,000
	<u>2,530,045</u>

The note payable to the City of Loveland contains job creation incentives whereby each annual payment may be forgiven by the City upon the Company meeting minimum job creation benchmarks. This loan agreement amended the incentives to 30 full time employees within the City of Loveland with payroll totaling \$135,000 by October 31, 2013 and 40 employees with payroll totaling \$175,000 by July 31, 2014, continuing with an average of 40 employees with payroll totaling \$175,000 thereafter. The proceeds from this loan were to be used for qualified disbursements only, and the Company has been notified it did not meet the requirements for qualified disbursements and for forgiveness of the 2012 principal and interest payment, which is past due. In 2013 the Company made payments to an escrow account totaling \$22,900.

4. SUBSCRIPTION AGREEMENTS

AMP Holding Inc. (the "Company"), entered into Subscription Agreements with five accredited investors (the "December 2014 Investors") between November 24, 2014 and December 29, 2014 providing for the sale by the Company to the December 2014 Investors of 14% Unsecured Convertible Promissory Notes in the aggregate amount of \$1,242,900 (the "December 2014 Notes"). In addition to the December 2014 Notes, the December 2014 Investors also received common stock purchase warrants (the "December 2014 Warrants") to acquire 4,439,287 shares of common stock of the Company. The December 2014 Warrants are exercisable for five years at an exercise price of \$0.14. The initial closing of \$200,000 was on November 24, 2014, the second closing of \$700,000 was on December 8, 2014 and the third closing of \$343,000 was on December 30, 2014.

The December 2014 Notes mature one year from their respective effective dates (the "Maturity Dates") and interest associated with the December 2014 Notes is 14% per annum, which is payable on the Maturity Dates. The December 2014 Notes are convertible into shares of common stock of the Company automatically upon the Company increasing its authorized shares of common stock to allow for full conversion of the December 2014 Notes. The December 2014 Notes and the December 2014 Warrants carry standard anti-dilution provisions. Further, for a period of six months from issuance, upon the issuance of common stock or common stock equivalents at a price lower than the conversion price or the exercise price, the conversion price in the December 2014 Notes and the exercise price in the December 2014 Warrants will be reduced to such lower price. Dawson James Securities, Inc. acted as placement agent and received compensation of \$68,365 and a common stock purchase warrant exercisable at \$0.14 per share to acquire 1,198,607 shares of common stock for a period of five years.

The Company claims an exemption from the registration requirements of the Securities Act of 1933 (the "Securities Act") for the private placement of these securities pursuant to Section 4(2) of the Securities Act and/or Rule 506 of Regulation D promulgated under the Securities Act. The investors are accredited investors as defined in Rule 501 of Regulation D promulgated under the Securities Act. As of the date hereof, the Company is obligated on \$1,243,000 in face amount of December 2014 Notes issued to the December 2014 Investors.

5. SHAREHOLDER AND RELATED PARTY ADVANCES

Investor advances are as follows:

December 31, 2014	December 31, 2013	Rate	Date	Expire	Note
-	43,000	3%	11 /30/2009	3 /31/2012	1
-	15,000	10%	10 /5/2012	10 /5/2013	1
-	100,000	10%	10 /16/2012	10 /16/2013	1
-	100,000	10%	10 /16/2012	10 /16/2013	1
-	50,000	10%	10 /19/2012	10 /19/2013	1
-	50,000	10%	11 /2/2012	11 /2/2013	1
-	50,000	10%	11 /8/2012	11 /8/2013	1
-	100,000	10%	12 /6/2012	12 /6/2013	1
-	50,000	10%	12 /19/2012	12 /19/2013	1
-	3,200	10%	10 /10/2013	10 /10/2014	1
-	2,500	10%	11 /5/2013	11 /5/2014	1
-	200,000	10%	11 /12/2013	11 /12/2014	2
-	50,000	10%	12 /2/2013	12 /2/2014	1
-	50,000	10%	12 /30/2013	12 /30/2014	1
-	80,000		12 /11/2013		2
-	990,600		Various 2013/14		3
-	<u>1,934,300</u>				

1 Advances were converted into equity during the second quarter of 2014

2 Paid in full during 2014.

3 Various non-interest bearing shareholders' deposits converted into equity third quarter 2014.

6. LEASE OBLIGATIONS

On October 1, 2011 the Company began leasing operating facilities under an agreement expiring on December 31, 2018. Future minimum monthly lease payments under the agreement are currently \$12,598 and increase 3% in October of each year. Prepaid expenses and deposits include a security deposit equal to \$12,275. Aggregate maturities of lease obligations are as follows:

2015	156,881
2016	161,588
2017	166,435
2018	127,614
	<u>612,518</u>

Total rent expense under these operating type leases for the years ended December 31, 2014 and 2013 was \$152 thousand and \$147 thousand, respectively, and \$752 thousand for the period from inception to December 31, 2014.

7. STOCK BASED COMPENSATION

Options to directors, officers and employees

The Company maintains, as adopted by the board of directors, the Incentive Stock Plans providing for the issuance of up to 25 million options to employees, officers, directors or consultants of the Company. Incentive stock options granted under the plans may only be granted with an exercise price of not less than fair market value of the Company's common stock on the date of grant (110% of fair market value for incentive stock options granted to principal stockholders). Non-qualified stock options granted under the plans may only be granted with an exercise price of not less than 85% of the fair market value of the Company's common stock on the date of grant. Awards under the plans may be either vested or unvested options. The unvested options vest ratably over two years for options with a five or three year term and after one year for options with a two year term.

In addition to the plans, the Company has granted, on various dates, stock options to directors, officers and employees to purchase common stock of the Company. The terms, exercise prices and vesting of these awards vary.

The following table summarizes option activity for directors, officers and employees:

	Shares Available for Grant	Number of Shares	Outstanding Stock Options		
			Weighted Average Exercise Price per Share	Weighted Average Grant Date Fair Value per Share	Weighted Average Remaining Exercise Term in Months
Balance, December 31 2012	6,080,000	6,420,874	\$ 0.50	\$ 0.25	44
Additional stock reserved	-	-	\$ -	\$ -	-
Granted	(2,100,000)	2,100,000	\$ 0.29	\$ 0.12	47
Exercised	-	(21,126)	\$ -	\$ -	-
Forfeited	-	-	\$ -	\$ -	-
Expired	505,000	(505,000)	\$ 0.70	\$ 0.20	-
Balance, December 31, 2013	4,485,000	7,994,748	\$ 0.45	\$ 0.23	36
Additional stock reserved	5,000,000	-	\$ -	\$ -	-
Granted	(8,675,926)	8,675,926	\$ 0.05	\$ 0.08	58
Exercised	-	-	\$ -	\$ -	-
Forfeited	-	-	\$ -	\$ -	-
Expired	-	-	\$ -	\$ -	-
Balance, December 31, 2014	809,074	16,670,674	\$ 0.23	\$ 0.15	41

The Company recorded \$171,666, \$421,281 and \$ 2,363,295 compensation expense for stock options to directors, officers and employees for the years ended December 31, 2014, 2013 and the period from inception (February 20, 2007) to December 31, 2014, respectively. As of December 31, 2014, unrecognized compensation expense of \$575,369 is related to non-vested options granted to directors, officers and employees which is anticipated to be recognized over the next 40 months, commensurate with the vesting schedules.

Options to consultants

The Company has also granted, on various dates, stock options to purchase common stock of the Company to consultants for services previously provided to the Company. The terms, exercise prices and vesting of these awards vary.

The following table summarizes option activity for consultants:

	Outstanding Stock Options				
	Shares Available for Grant	Number of Shares	Weighted Average Exercise Price per Share	Weighted Average Grant Date Fair Value per Share	Weighted Average Remaining Exercise Term in Months
Balance, December 31 2012	561,000	1,825,000	\$ 0.57	\$ 0.23	21
Additional stock reserved	-	-	\$ -	\$ -	-
Granted	(400,000)	400,000	\$ 0.21	\$ 0.10	56
Exercised	-	-	\$ -	\$ -	-
Forfeited	-	-	\$ -	\$ -	-
Expired	810,000	(810,000)	\$ 0.67	\$ 0.23	-
Balance, December 31, 2013	971,000	1,415,000	\$ 0.41	\$ 0.20	34
Additional stock reserved	2,000,000	-	\$ -	\$ -	-
Granted	(2,967,727)	2,967,727	\$ 0.01	\$ 0.10	54
Exercised	-	-	\$ -	\$ -	-
Forfeited	200,000	(200,000)	\$ -	\$ -	-
Expired	190,000	(190,000)	\$ 0.50	\$ 0.17	-
Balance, December 31, 2014	393,273	3,992,727	\$ 0.13	\$ 0.13	50

The Company recorded \$154,199, \$68,747 and \$526,984 compensation expense for stock options to consultants for the years ended December 31, 2014, 2013 and for the period from inception (February 20, 2007) to December 31, 2014, respectively. As of December 31, 2014, unrecognized compensation expense of \$233,869 is related to non-vested options granted to consultants which is anticipated to be recognized over the next 40 months, commensurate with the vesting schedules.

Warrants to placement agent and consultants

Through December 2011, the Company compensated the placement agent for assisting in the sale of the Company's securities by paying the placement agent commissions and issuing the placement agent common stock purchase warrants to purchase shares of the Company's common stock. The warrants have a five year term and various exercise prices.

The Company has also granted, on various dates, stock warrants to purchase common stock of the Company to consultants for services previously provided to the Company. The terms, exercise prices and vesting of these awards vary.

The following table summarizes warrant activity for the placement agent and consultants:

	Shares Available for Grant	Number of Shares	Outstanding Warrants		
			Weighted Average Exercise Price per Share	Weighted Average Grant Date Fair Value per Share	Weighted Average Remaining Exercise Term in Months
Balance, December 31 2012	4,339,590	3,130,894	\$ 0.46	\$ 0.21	36
Additional stock reserved	-	-	\$ -	\$ -	-
Granted	-	-	\$ -	\$ -	-
Exercised	-	-	\$ -	\$ -	-
Forfeited	-	-	\$ -	\$ -	-
Expired	-	-	\$ -	\$ -	-
Balance, December 31, 2013	4,339,590	3,130,894	\$ 0.46	\$ 0.21	24
Additional stock reserved	-	-	\$ -	\$ -	-
Granted	(1,598,607)	1,598,607	\$ 0.17	\$ 0.06	34
Exercised	-	-	\$ -	\$ -	-
Forfeited	-	-	\$ -	\$ -	-
Expired	-	(628,013)	\$ 0.39	\$ 0.18	-
Balance, December 31, 2014	2,740,983	4,101,488	\$ 0.36	\$ 0.15	14

The Company recorded \$88,733, \$0 and \$697,651 compensation expense for stock warrants to the placement agent and consultants for the years ended December 31, 2014, 2013 and for the period from inception (February 20, 2007) to December 31, 2014, respectively. There is no unrecognized compensation expense for the placement agent warrants because they are fully vested at date of grant.

Warrants to directors and officers

In December 2010 and May 2011, the Company issued to certain directors and officers common stock purchase warrants to acquire shares of common stock at an exercise price of \$2.00 per share for a period of five years. In November 2011, under the terms of a Promissory Note issued to a director and officer, common stock purchase warrants were issued to acquire 100,000 shares of common stock at an exercise price of \$0.50 per share for a period of one year. In May 2012, a director and officer received 100,000 2012 Warrants to acquire common stock of the Company at an exercise price of \$0.50 for a period of three years. In June 2012, a director and officer converted secured and unsecured loans provided to the Company from September 2011 to June 2012 in the aggregate amount of \$389,250 into 2012 Notes and 2012 Warrants. In November 2012, the Company entered into a Note and Warrant Amendment and Conversion Agreement whereby the holders and 2012 Investors converted all principal and interest under the 2012 Notes into shares of common stock. Further, the exercise price of the 2012 Warrants was reduced to \$0.25 per share. The \$7,388 cost of the reduction in the exercise price is included in stock based compensation expense for the year ended December 31, 2012.

The following table summarizes warrant activity for directors and officers:

	Shares Available for Grant	Number of Shares	Outstanding Warrants		
			Weighted Average Exercise Price per Share	Weighted Average Grant Date Fair Value per Share	Weighted Average Remaining Exercise Term in Months
Balance, December 31 2012	3,389,250	3,489,250	\$ 1.75	\$ 0.09	29
Additional stock reserved	-	-	\$ -	\$ -	-
Granted	-	-	-	-	-
Exercised	-	-	-	-	-
Forfeited	-	-	-	-	-
Expired	100,000	(100,000)	0.50	0.10	-
Balance, December 31, 2013	3,489,250	3,389,250	\$ 1.78	\$ 0.09	22
Additional stock reserved	-	-	\$ -	\$ -	-
Granted	-	-	0.17	-	-
Exercised	-	-	-	-	-
Forfeited	-	-	-	-	-
Expired	-	-	-	-	-
Balance, December 31, 2014	3,489,250	3,389,250	\$ 1.78	\$ 0.09	9

The Company recorded \$0, \$0 and \$331,428 compensation expense for stock warrants to directors and officers for the years ended December 31, 2014, 2013 and for the period from inception (February 20, 2007) to December 31, 2014, respectively. There is no unrecognized compensation expense for these warrants because they are fully vested at date of grant.

8. RECENT PRONOUNCEMENTS

In June 2014, The FASB issued ASU No. 2014-12, Compensation – Stock Compensation (Topic 718): Accounting for Share-Based Payments When the Terms of an Award Provide That a Performance Target Could Be Achieved after the Requisite Service Period. The amendments in the ASU require that a performance target that affects vesting and that could be achieved after the requisite service period be treated as a performance condition. A reporting entity should apply existing guidance in Topic 718, Compensation – Stock Compensation, as it relates to awards with performance conditions that affect vesting to account for such awards. The amendments in this ASU are effective for annual periods and interim periods within those annual periods beginning after December 15, 2015. Earlier adoption is permitted. The effective date is the same for both public business entities and all other entities. We do not expect the adoption of these provisions to have a significant impact on the Company's consolidated financial statements.

In May 2014, The FASB issued ASU No. 2014-09, Revenue from Contracts with Customers: Topic 606. ASU 2014-09 affects any entity using U.S. GAAP that either enters into contracts with customers to transfer goods or services or enters into contracts for the transfer of nonfinancial assets unless those contracts are within the scope of other standards (e.g., insurance contracts or lease contracts). For a public entity, the amendments in this ASU are effective for annual reporting periods beginning after December 15, 2016, including interim periods within that reporting period. Early application is not permitted. We do not expect the adoption of these provisions to have a significant impact on the Company's consolidated financial statements.

9. SUBSEQUENT EVENTS

We have received orders from a national fleet for 18 full electric vehicles to be delivered during 2015. We also have orders for 2 E-Gen vehicles for the same company, we delivered the first truck on March 24, 2015 and the second one will be delivered on March 30, 2015.

ITEM 9. CHANGES IN AND DISAGREEMENTS WITH ACCOUNTANTS ON ACCOUNTING AND FINANCIAL DISCLOSURE

None

ITEM 9A. CONTROLS AND PROCEDURES

(a) Evaluation of Disclosure Controls and Procedures

Our principal executive and principal financial officers have evaluated the effectiveness of our disclosure controls and procedures, as defined in Rules 13a – 15(e) and 15d – 15(e) under the Securities Exchange Act of 1934, as amended (the “Exchange Act”), as of the end of the period covered by this annual report. They have concluded that, based on such evaluation, our disclosure controls and procedures were effective as of December 31, 2014.

(b) Management’s Annual Report on Internal Control Over Financial Reporting

Overview

Internal control over financial reporting as defined in Rules 13a-15(f) and 15d-15(f) refers to the process designed by, or under the supervision of, our principal executive officer and principal financial officer, and effected by our board of directors, management and other personnel, to provide reasonable assurance regarding the reliability of financial reporting and the preparation of financial statements for external purposes in accordance with generally accepted accounting principles in the United States of America. Management is responsible for establishing and maintaining adequate internal control over financial reporting for AMP.

Internal control over financial reporting cannot provide absolute assurance of achieving financial reporting objectives because of its inherent limitations. Internal control over financial reporting is a process that involves human diligence and compliance and is subject to lapses in judgment and breakdowns resulting from human failures. Internal control over financial reporting also can be circumvented by collusion or improper management override. Because of such limitations, there is a risk that material misstatements may not be prevented or detected on a timely basis by internal control over financial reporting. However, these inherent limitations are known features of the financial reporting process. Therefore, it is possible to design into the process safeguards to reduce, though not eliminate, this risk.

Management has used the framework set forth in the report entitled “Internal Control -- Integrated Framework (2009)” published by the Committee of Sponsoring Organizations (“COSO”) of the Treadway Commission to evaluate the effectiveness of AMP’s internal control over financial reporting. A material weakness is a deficiency, or a combination of deficiencies, in internal control over financial reporting such that there is a reasonable possibility that a material misstatement of our annual or interim financial statements will not be prevented or detected on a timely basis.

Management’s Assessment

As of December 31, 2014, our management has assessed the effectiveness of our internal control over financial reporting and has determined that our internal control over financial reporting was effective. We are a smaller reporting company and are therefore exempt from having to obtain an auditors’ report on management’s assertion of the effectiveness of our internal control over financial reporting. Based on the measures taken and implemented, management has found them to be effective and has concluded that the material weakness previously reported as been remediated as of December 31, 2014.

(c) Changes in Internal Control over Financial Reporting

There have been no changes in our internal control over financial reporting that occurred during the fourth fiscal quarter of the year ended December 31, 2014 that have materially affected, or are reasonably likely to materially affect, our internal control over financial reporting.

ITEM 9B. OTHER INFORMATION

Cash

The cash balance at the end of March 2015 is \$503 thousand.

Accounts Payable

The company has numerous delinquent current obligations to suppliers, and business contracts. As of December 31, 2014 the accounts payable balance is \$1.1 million. Obligations are being prioritized for payment as the timing of receipt of funds allows. Proactive communications to suppliers for delinquent current obligations have been ongoing. Additionally, several suppliers have been offered common stock of the Company in exchange of foregoing the balance due to them.

PART III

ITEM 10. DIRECTORS, EXECUTIVE OFFICERS AND CORPORATE GOVERNANCE

The officers and director of the Company are as follows:

Name	Age	Position
James E. Taylor	57	Director
Stephen S. Burns	54	Director, Chief Executive Officer, Secretary and Treasurer
Martin J. Rucidlo	56	President
Julio C. Rodriguez	56	Chief Financial Officer
Raymond J. Chess	57	Director
Marshall S. Cogan	77	Chairman of the Board of Directors and Chief Investment Officer

Officers are elected annually by the Board of Directors (subject to the terms of any employment agreement) to hold such office until an officer's successor has been duly appointed and qualified, unless an officer sooner dies, resigns or is removed by the Board.

Our officers and directors have not been the subject of any order, judgment, or decree of any court of competent jurisdiction, or any regulatory agency permanently or temporarily enjoining, barring, suspending or otherwise limiting them from acting as an investment advisor, underwriter, broker or dealer in the securities industry, or as an affiliated person, director or employee of an investment company, bank, savings and loan association, or insurance company or from engaging in or continuing any conduct or practice in connection with any such activity or in connection with the purchase or sale of any securities.

Our officers and directors have not been convicted in any criminal proceeding (excluding traffic violations) and are not the subject of any criminal proceedings which are currently pending.

Background of Executive Officers and Directors

James E. Taylor, Director

Mr. Taylor has three decades of automotive experience in three countries. Most recently, he served as CEO of Hummer during the divestiture. Prior to that, he was President of Cadillac, responsible for the product planning, marketing, promotional and sales activities that significantly contributed to Cadillac's global renaissance. Prior to that, Mr. Taylor was a vehicle line executive for Cadillac, directing the planning, engineering and manufacturing of the award-winning ground up Cadillac CTS, SRX and the STS models, which contributed significantly to the resurgence of Cadillac. Mr. Taylor holds a Bachelor of Science degree in Mechanical Engineering & Management from McMaster University, Ontario, Canada.

Stephen S. Burns, Director, Chief Executive Officer, Treasurer and Secretary

Mr. Burns is a Co-Founder in AMP and has served as AMP's CEO since inception. Mr. Burns was appointed as CEO, CFO, Treasurer and Secretary of the Company on December 28, 2009. Mr. Burns had founded several companies, most recently iTookThisOnMyPhone.com, a mobile photo and video-sharing technology company, MobileVoiceControl, Inc. a developer of high-end speech recognition software for smartphones sold to Nuance Communications (NASDAQ:NUAN), Inc. in 2006, AskMeNow [OTC:AKMN] a mobile search and information delivery system sold to Ocean West Holdings in 2005, PocketScript, the leading mobile electronic prescription system in the world which was sold to ZixCorp [NASDAQ:ZIXI] in 2002, Over The Line/AdLink, sold to Gannett Co. Inc. (NYSE:GCI) in 1994 and the design and development of Suspension Parameter Measurement Machines.

Raymond J. Chess, Director

Prior to joining the Company, Mr. Chess served as a Global Vehicle Line Executive for General Motors Co. ("GM"), where he was responsible for global, cross functional general management of the GM crossover market segment from May 2009 through December 2012. Prior to this, from August 2001 until April 2009, Mr. Chess was responsible for GM's commercial truck segment. Previous GM assignments included leadership roles in the full size truck segment, metal fabrication and body assembly. Mr. Chess's background includes broad, hands-on manufacturing leadership roles with manufacturing, engineering and manufacturing floor operations. Mr. Chess holds a Bachelor's of Science degree in Mechanical Engineering from Kettering University and an MBA from Indiana University.

Martin J. Rucidlo, President

Mr. Rucidlo has over 25 years of experience in a variety of industries ranging from VP Sales & Marketing to General Manager positions in the aerospace, packaging, software, medical technology, and automotive industries. He has held executive-level positions at Zix Corporation, Quest Diagnostics Inc., Nuance Communications., PCC Airfoils and Alcoa. He holds a Bachelors of Science Degree in Industrial Engineering from The Pennsylvania State University.

Julio C. Rodriguez, Chief Financial Officer

Mr. Rodriguez is a finance executive with over 30 years of experience in financial and operational leadership roles within various industries including the automotive industry. Most recently, he served in various executive roles for Genuine Parts Company ("GPC") including Director Process Improvement for GPC corporate, and Vice President Finance & Corporate Secretary for Johnson Industries, a subsidiary

of GPC. Prior to GPC Mr. Rodriguez served as Director of International Finance for Federal Mogul an OEM manufacturer of automotive systems. Mr. Rodriguez holds a Bachelor of Science degree in Business Administration and a Bachelor of Science degree in Accounting from Catholic University Caracas, Venezuela.

Marshall S. Cogan, Chief Investment Officer and Chairman of the Board of Directors

Marshall Cogan was the Chairman and Chief Executive Officer of Foamex International until April 1997, Vice Chairman until 1999 and Chairman and executive officer (but not chief executive officer) until February 2004 when he resigned in all capacities. Mr. Cogan was the Chairman and Chief Executive Officer and founder of United Auto Group, a United States public company that operates automobile dealerships in the United States from 1990 through 1999 and a director of the company until April 2001. From 1974 until 1999, Mr. Cogan was also the Chairman and Chief Executive Officer of Trace International Holdings, Inc. (the successor of GFI Holdings, Knoll International Holdings and '21' International Holdings). Mr. Cogan served on the Board of Directors of Ener1, Inc. from February 2006 through December 2010. From 1977 to 1990 Mr. Cogan was Chairman and Chief Executive Officer of Knoll International and served with that corporation as Chairman Emeritus until 1992. From 1974 to 1988, Mr. Cogan was Chairman and Chief Executive Officer of General Felt Industries, Inc. From 1964 to 1973 he served in various positions with CBWL-Hayden Stone, Inc. a predecessor to Shearson Lehman/American Express and as Vice Chairman from 1971 to 1973. From 1983 to 2004, Mr. Cogan served as a Trustee of New York University Hospital, and he presently serves Boston Latin School and the Israel Museum in that capacity. He is a member of various committees with Harvard University, is a director of the American Friends of the Israel Museum, is a member of various committees with Harvard University, is a director of the American Friends of Israel Museum and was an advisor to Senator Edward M. Kennedy until his death. At various times in his career Mr. Cogan owned and controlled the '21' Club, Color Tile Inc. and Sheller-Globe Corporation. Mr. Cogan was a trustee of the Museum of Modern Art from 1982 to 2004 and Chairman of the museum's architecture and design department for ten years. Mr. Cogan received an MBA from the Harvard University School of Business Administration as well as an undergraduate degree from Harvard College.

Family Relationships

There are no family relationships among our directors and executive officers. There is no arrangement or understanding between or among our executive officers and directors pursuant to which any director or officer was or is to be selected as a director or officer.

Involvement in Certain legal Proceedings

To our knowledge, during the last ten years, none of our directors and executive officers has:

- Had a bankruptcy petition filed by or against any business of which such person was a general partner or executive officer either at the time of the bankruptcy or within two years prior to that time.
- Been convicted in a criminal proceeding or been subject to a pending criminal proceeding, excluding traffic violations and other minor offenses.
- Been subject to any order, judgment or decree, not subsequently reversed, suspended or vacated, of any court of competent jurisdiction, permanently or temporarily enjoining, barring, suspending or otherwise limiting his involvement in any type of business, securities or banking activities.
- Been found by a court of competent jurisdiction (in a civil action), the SEC, or the Commodities Futures Trading Commission to have violated a federal or state securities or commodities law, and the judgment has not been reversed, suspended or vacated.
- Been the subject to, or a party to, any sanction or order, not subsequently reverse, suspended or vacated, of any self-regulatory organization, any registered entity, or any equivalent exchange, association, entity or organization that has disciplinary authority over its members or persons associated with a member.

CORPORATE GOVERNANCE

Governance Policies of the Board of Directors

The Board of Directors has adopted Governance Policies of the Board of Directors to assist the Board in the exercise of its duties and responsibilities and to serve the best interests of the Company and its stockholders. These policies provide a framework for the conduct of the Board's business.

Committees

The Board of Directors is currently evaluating committee charters with the goal of establishing the following committees: Governance Committee, Compensation Committee, Personnel Committee, and Audit Committee. The Board of Directors does not have a standing nominating committee. Nominations for election to the Board of Directors may be made by the Board of Directors or by any shareholder entitled to vote for the election of directors in accordance with our bylaws and Nevada law.

Meetings may be held from time to time to consider matters for which approval of our Board of Directors is desirable or is required by law.

Code of Ethics

We have implemented a corporate code of ethics.

Company Policies

The Company has established the following written policies that have been distributed and reviewed with all Company employees: Approval policy, Purchase Requisition policy, Conflict of Interest policy, "Do the Right Thing (ethics) policy and a Travel and Expense policy.

Compensation of Directors

We have entered into the following arrangements:

On October 11, 2010, Mr. Taylor entered into a letter agreement with the Company pursuant to which he was appointed as a director of the Company in consideration of an annual fee of \$40,000. Additionally, the Company granted Mr. Taylor options to purchase 325,000 shares of the Company's common stock at \$0.68 per share. The options will expire five years from the vesting period with 75,000 options vesting upon the signing of the agreement and 50,000 every six months thereafter for a total of 325,000 shares. On February 13, 2015, the Company entered into an agreement with Mr. Taylor whereby Mr. Taylor agreed to waive his right to \$187,850 in accrued fees in consideration for \$50,000 in cash upon the Company raising capital and an option, issued under the 2014 Stock Compensation Plan, to acquire 774,356 shares of common stock at an exercise price of \$0.01 per share.

On October 24, 2013, the size of the Board of Directors was increased from two to three and Raymond J. Chess was appointed as a director of the Company. Prior to joining the Board of Directors, Mr. Chess served on our advisory board pursuant to which he received a stock option to acquire 100,000 shares of common stock at an exercise price of \$0.25 per share. On October 24, 2013, Mr. Chess entered into a letter agreement with the Company pursuant to which he was appointed as a director of the Company in consideration of an annual fee of \$40,000. Additionally, the Company granted Mr. Chess options to purchase 500,000 shares of the Company's common stock at US\$0.26 per share. The options will expire five years from the vesting period with 100,000 options vesting upon the signing of the agreement and 40,000 every six months thereafter for a total of 500,000 shares.

On February 13, 2015, Marshall S. Cogan was engaged by AMP to serve as the Chief Investment Officer and Chairman of the Board of Directors of the Company. On February 13, 2015, the Company and Mr. Cogan entered into an Executive Employment Agreement pursuant to which he was appointed as the Chief Investment Officer in consideration of an annual salary of \$135,000. Additionally, Mr. Cogan will be eligible for annual bonuses, which shall be half of the Chief Executive Officer's bonus. As additional compensation, the Company granted Mr. Cogan options to acquire 7,500,000 shares of common stock at an exercise price of \$0.15 per share for a period of three years, which vest over a three year period in equal tranches of 2,500,000 shares on the one year, two year and three year anniversary of Mr. Cogan's employment.

Section 16(a) Beneficial Ownership Reporting Compliance

Section 16(a) of the Securities Exchange Act of 1934, as amended, requires our directors and executive officers and persons who own more than 10% of the issued and outstanding shares of our common stock to file reports of initial ownership of common stock and other equity securities and subsequent changes in that ownership with the SEC. Officers, directors and greater than ten percent stockholders are required by SEC regulation to furnish us with copies of all Section 16(a) forms they file. To our knowledge, based solely on a review of the copies of such reports furnished to us and written representations that no other reports were required, during the fiscal year ended December 31, 2014 all Section 16(a) filing requirements applicable to our officers, directors and greater than 10% beneficial owners were complied with.

ITEM 11. EXECUTIVE COMPENSATION

The following summary compensation table sets out details of compensation paid to (a) our principal executive officer; (b) each of our two most highly compensated executive officers who served as executive officers during the fiscal year ended December 31, 2014; and (c) up to two additional individuals for whom disclosure would have been provided under (b) but for the fact that the individual was not serving as our executive officer at the end of the fiscal year ended December 31, 2014, except that no disclosure is provided for any named executive officer, other than our principal executive officer, whose total compensation did not exceed \$100,000 for the fiscal year ended December 31, 2014:

Summary Compensation Table

Name and Principal Position	Year	Salary (\$)	Bonus (\$)	Stock Awards (\$)	Option Awards (\$)	Non-equity Incentive Plan Compensation (\$)	Change in Pension Value and Non- Qualified Deferred Compensation Earnings (\$)	All Other Compensation (\$)	Total (\$)
James E. Taylor Chairman of the Board (1)	2014				7,020			80,000	87,020
	2013	-	-	-	-	-	-	80,000	80,000
	2014	200,000			256,034				456,034
Stephen S. Burns CEO and Director	2013	200,000	-	-	11,160	-	-	-	211,160
Martin J. Rucidlo	2014	125,000			112,074				237,074

President	2013	125,000	-	-	30,600	-	-	-	155,600
Julio C. Rodriguez	2014	150,000			66,804				216,804
Chief Financial Officer	2013	150,000	-	-	45,000	-	-	-	195,000

(1) Resigned as CEO effective August 10, 2012

Employment Agreements

James E. Taylor Employment Agreement

On December 8, 2010, we entered into an employment agreement with James E. Taylor pursuant to which he was appointed as the Chief Executive Officer and Vice-Chairman of the Company in consideration of an annual salary of \$300,000. Additionally, Mr. Taylor was eligible for annual bonuses with a target amount of 100% of his salary. As additional compensation, we granted Mr. Taylor options to acquire 1,200,000 shares of common stock at an exercise price of \$0.72 per share for a period of ten years. We also provided Mr. Taylor with a common stock purchase warrant to acquire 600,000 shares of common stock exercisable at any time in the five years following the signing of the agreement at an exercise price of \$2.00 per share. Effective August 10, 2012, Mr. Taylor resigned as the CEO and continues to serve as a director. As of December 31, 2014, payroll in the amount of \$87,500 was due and payable and included in accounts payable, based on terms of Mr. Taylor's employment agreement. On February 13, 2015, the Company entered into an agreement with Mr. Taylor whereby Mr. Taylor agreed to waive his right to \$187,850 in accrued fees in consideration for \$50,000 in cash upon the Company raising capital and an option, issued under the 2104 Stock Compensation Plan, to acquire 774,356 shares of common stock at an exercise price of \$0.01 per share.

Stephen S. Burns Employment Agreement

On December 8, 2010, Stephen S. Burns entered into an employment agreement with the Company pursuant to which he was appointed as the President of the Company in consideration of an annual salary of \$200,000, however, only 50% of the salary (\$100,000) will be payable at this time. The remaining 50% of the salary will accrue and be deferred until the board of directors elects to increase the salary to include all or a portion of the deferred salary based on certain events. Additionally, Mr. Burns will be eligible for annual bonuses with a target amount of 100% of his salary. The actual amount of any bonus may be more or less than such target and will be determined by the Board in its absolute discretion. Half of the bonus may be paid, in the Company's discretion, in unregistered shares of common stock at a price per share equal to the weighted average closing price per share of the common stock over the twenty most recent trading days prior to such grant. In addition to the salary and any bonus, Mr. Burns will be entitled to receive health and fringe benefits that are generally available to the Company's management employees in accordance with the then existing terms and conditions of the Company's policies. As additional compensation, the Company granted Mr. Burns options to acquire 300,000 shares of common stock at an exercise price of \$0.72 per share for a period of ten years. The Company also provided Mr. Burns with a common stock purchase warrant to acquire 300,000 shares of Common Stock exercisable at any time in the five years following the signing of the agreement at an exercise price of \$2.00 per share. Effective August 24, 2012, Mr. Burns resigned as President and continues to serve as a director as well as Chief Executive Officer, Secretary and Treasurer of the Company. As of December 31, 2014, payroll in the amount of \$108,335 was due and payable and included in accounts payable, based on terms of Mr. Burns's employment agreement.

Martin J. Rucidlo Employment Agreement

On August 24, 2012, Martin J. Rucidlo was engaged by the Company to serve as the President of the Company. Mr. Rucidlo replaced Stephen S. Burns who resigned as President and continues to serve as a director as well as Chief Executive Officer, Secretary and Treasurer of the Company. On August 24, 2012, Mr. Rucidlo entered into a letter agreement with the Company pursuant to which he was appointed as the President of the Company in consideration of an annual salary of \$125,000. As additional compensation, the Company granted Mr. Rucidlo options to purchase 300,000 shares of the Company's common stock at an exercise price of \$0.21 per share. The options will expire three years from the vesting period with 90,000 options vesting upon the signing of the Agreement and 105,000 options vesting each of the following two years on the anniversary date of the Agreement for a total of 300,000 shares. As of December 31, 2014, payroll in the amount of \$52,085 was due and payable and included in accounts payable, based on terms of Mr. Rucidlo's employment agreement.

Julio C. Rodriguez Employment Agreement

On August 15, 2013, Julio C. Rodriguez and the Company entered into an employment Agreement pursuant to which Mr. Rodriguez agreed to serve as the Chief Financial Officer of the Company. The Agreement has an effective date of August 7, 2013. Mr. Rodriguez will replace Richard J. Calme who resigned as the Interim Chief Financial Officer. Mr. Calme has been appointed to serve as Director of Finance of the Company. Pursuant to the terms of the Employment Agreement, Mr. Rodriguez shall receive an annual salary of \$150,000. In addition to the salary, Mr. Rodriguez will be entitled to receive health and fringe benefits that are generally available to the Company's management employees. As additional compensation, the Company granted Mr. Rodriguez options to acquire 300,000 shares of common stock at an exercise price of \$0.40 per share for a period of two years.

Marshall S. Cogan Executive Employment Agreement

On February 13, 2015, Marshall S. Cogan was engaged by AMP to serve as the Chief Investment Officer and Chairman of the Board of Directors of the Company. On February 13, 2015, the Company and Mr. Cogan entered into an Executive Employment Agreement pursuant to which he was appointed as the Chief Investment Officer in consideration of an annual salary of \$135,000. Additionally, Mr. Cogan will be eligible for annual bonuses, which shall be half of the Chief Executive Officer's bonus. As additional compensation, the Company granted Mr. Cogan options to acquire 7,500,000 shares of common stock at an exercise price of \$0.15 per share for a period of three years, which vest over a three year period in equal tranches of 2,500,000 shares on the one year, two year and three year anniversary of Mr. Cogan's employment.

The following table sets forth information with respect to the outstanding equity awards of our principal executive officers and principal financial officer during 2014, and each person who served as an executive officer of the Company as of December 31, 2014:

Outstanding Equity Awards at Fiscal Year-End

Name and principal position	Option awards				Stock awards				Equity incentive plan awards: Market or payout value of unearned shares, units or other rights that have not vested (\$)
	Number of securities underlying unexercised options (#) Exercisable	Number of securities underlying unexercised options (#) Unexercisable	Equity incentive plan awards: Number of securities underlying unexercised options (#)	Options exercise price (\$)	Option expiration Date	Number of shares or units of stock that have not vested (#)	Market value of shares or units of stock that have not vested (\$)	Equity incentive plan awards: Number of unearned shares other rights that have not vested (#)	
James E. Taylor Chairman of the Board (1)	292,825	32,175	0	\$ 0.68	10 /11/2015	0	\$ 0	0	\$ 0
	1,200,000	0	0	\$ 0.72	12 /8/2020	0	\$ 0	0	\$ 0
	600,000	0	0	\$ 2.00	12/8/2015	0	\$ 0	0	\$ 0
	500,000	0	0	\$ 0.60	5 /25/2016	0	\$ 0	0	\$ 0
	500,000	0	0	\$ 2.00	5 /25/2016	0	\$ 0	0	\$ 0
	196,615	103,385	0	\$ 0.15	8 /10/2017	0	\$ 0	0	\$ 0
	110,000	190,000	0	\$ 0.29	3 /14/2018	0	\$ 0	0	\$ 0
	25,000	75,000	0	\$ 0.14	12 /18/2019	0	\$ 0	0	\$ 0
Stephen S. Burns CEO and Director	600,000	0	0	\$ 0.40	5 /12/2015	0	\$ 0	0	\$ 0
	300,000	0	0	\$ 0.72	12 /8/2020	0	\$ 0	0	\$ 0
	300,000	0	0	\$ 2.00	12 /8/2015	0	\$ 0	0	\$ 0
	500,000	0	0	\$ 0.60	5 /25/2016	0	\$ 0	0	\$ 0
	500,000	0	0	\$ 2.00	5 /25/2016	0	\$ 0	0	\$ 0
	100,000	0	0	\$ 0.25	5 /2/2015	0	\$ 0	0	\$ 0
	389,250	0	0	\$ 0.25	6 /30/2015	0	\$ 0	0	\$ 0
	239,500	60,500	0	\$ 0.11	12 /4/2015	0	\$ 0	0	\$ 0
	146,667	253,333	0	\$ 0.29	3 /14/2018	0	\$ 0	0	\$ 0
	2,476,897	337,500	0	\$ 0.01	6 /30/2019	0	\$ 0	0	\$ 0
	125,000	375,000	0	\$ 0.14	12 /18/2019	0	\$ 0	0	\$ 0
Martin J. Rucidlo President	200,000	0	0	\$ 0.40	5 /12/2015	0	\$ 0	0	\$ 0
	50,000	0	0	\$ 0.70	6 /30/2013	0	\$ 0	0	\$ 0
	261,500	38,500	0	\$ 0.21	12 /8/2015	0	\$ 0	0	\$ 0
	199,583	50,417	0	\$ 0.11	12 /4/2015	0	\$ 0	0	\$ 0
	73,333	126,667	0	\$ 0.11	12 /4/2015	0	\$ 0	0	\$ 0
	1,029,447	202,500	0	\$ 0.01	6 /30/2019	0	\$ 0	0	\$ 0
	62,500	187,500	0	\$ 0.14	12 /18/2019	0	\$ 0	0	\$ 0
Julio C. Rodriguez CFO	156,667	143,333	0	\$ 0.40	8 /6/2018	0	\$ 0	0	\$ 0
	599,331	135,000	0	\$ 0.01	6 /30/2019	0	\$ 0	0	\$ 0
	37,500	112,500	0	\$ 0.14	12 /18/2019	0	\$ 0	0	\$ 0

Director Compensation

Name	Fees Earned or Paid in Cash \$	Stock Awards \$	Option Awards \$	Non-equity Incentive Plan Compensation \$	Change in Pension Value and Non-Qualified Deferred Compensation Earnings \$	All Other Compensation \$	Total (\$)
James E. Taylor	80,000	0	7,020	0	0	0	87,020
Raymond Chess	40,000		70,701	0	0	0	110,701

ITEM 12. SECURITY OWNERSHIP OF CERTAIN BENEFICIAL OWNERS AND MANAGEMENT AND RELATED STOCKHOLDER MATTERS

The following table sets forth certain information, as of March 27, 2015 with respect to the beneficial ownership of the outstanding common stock by (i) any holder of more than five (5%) percent; (ii) each of the Company's executive officers and directors; and (iii) the Company's directors and executive officers as a group. Except as otherwise indicated, each of the stockholders listed below has sole voting and investment power over the shares beneficially owned.

Name of Beneficial Owner (1)	Common Stock Beneficially Owned	Percentage of Common Stock (2)	
Joseph T. Lukens	53,401,301	32.2%	(3)
Stephen D. Baksa	26,616,227	16.9%	(4)
Stephen S. Burns	10,324,455	6.8%	(5)
Marshall S. Cogan *	0	0.0%**	
James Taylor *	2,238,609	1.5%	(6)
Raymond Chess *	345,283	0.2%	(7)
Martin Rucidlo *	513,563	0.3%	(7)
Julio C. Rodriguez *	156,814	0.1%	(7)
Executive officers and directors as a group	13,578,724	8.9%	

* Executive officer and/or director of the Company.

** Less than 1%

- (1) Except as otherwise indicated, the address of each beneficial owner is c/o Advanced Mechanical Products, Inc., 100 Commerce Drive, Loveland, Ohio 45140
- (2) Applicable percentage ownership is based on 149,944,982 shares of common stock outstanding as of December 31, 2014. Beneficial ownership is determined in accordance with the rules of the Securities and Exchange Commission and generally includes voting or investment power with respect to securities. Shares of common stock that are currently exercisable or exercisable within 60 days of December 31, 2014 are deemed to be beneficially owned by the person holding such securities for the purpose of computing the percentage of ownership of such person, but are not treated as outstanding for the purpose of computing the percentage ownership of any other person.
- (3) Includes 37,731,301 shares of common stock and common stock purchase warrants to acquire 15,670,000 shares of common stock.
- (4) Includes 19,376,941 shares of common stock and common stock purchase warrants to acquire 7,239,286 shares of common stock.
- (5) Includes 7,673,367 shares of common stock, common stock purchase warrants to acquire 1,932,750 shares of common stock and common stock purchase options to acquire 718,338 shares of common stock.
- (6) Includes common stock purchase warrants to acquire 1,100,000 shares of common stock and common stock purchase options to acquire 1,138,609 shares of common stock.
- (7) Includes common stock purchase options to acquire shares of common stock.

ITEM 13. CERTAIN RELATIONSHIPS AND RELATED TRANSACTIONS, AND DIRECTOR INDEPENDENCE

Transactions with Related Persons

At no time during the last two fiscal years has any executive officer, director or any member of these individuals' immediate families, any corporation or organization with whom any of these individuals is an affiliate or any trust or estate in which any of these individuals serves as a trustee or in a similar capacity or has a substantial beneficial interest been indebted to the Company or was involved in any transaction in which the amount exceeded \$120,000 and such person had a direct or indirect material interest.

Procedures for Approval of Related Party Transactions

Our Board of Directors is charged with reviewing and approving all potential related party transactions. All such related party transactions must then be reported under applicable SEC rules. We have not adopted other procedures for review, or standards for approval, of such transactions, but instead review them on a case-by-case basis.

Director Independence

The Board of Directors has determined that the Company does not have any independent directors as of December 31, 2014 based on the definition of independence in the listing standards of the Nasdaq Corporate Governance Rules. The Board of Directors is currently evaluating committee charters with the goal of establishing a Compensation Committee, a Governance and Nominating Committee and an Audit Committee.

ITEM 14. PRINCIPAL ACCOUNTING FEES AND SERVICES

The total fees charged to the Company by Clark Schaefer Hackett & Company, the Company's independent registered public accounting firm, are as follows (\$ thousands):

	Audit	Taxes	Other	Total
2014	68.5	4.7	0.3	73.5
2013	78.8	4.3	0.8	83.9
2012	59.8	6.0	0.8	66.6
2011	54.0	8.0	3.0	65.0

The current policy of the directors, acting as the audit committee, is to approve the appointment of the principal auditing firm and any permissible audit-related services. The audit and audit related fees include fees for the annual audit of the financial statements and review of financial statements included in 10Q filings. Fees charged by Clark, Schaefer Hackett & Company were approved by the Board with engagement letters signed by Stephen S. Burns, Chief Executive Officer.

PART IV

ITEM 15. EXHIBITS AND FINANCIAL STATEMENT SCHEDULES

The Company's financial statements filed as part of this report are listed in the Table of Contents and provided in response to Item 8.

Exhibits required by Item 601 of Regulation S-K:

Exhibit No.	Description
3.1	Certificate of Designation for Series A Preferred Stock (1)
3.2	Certificate of Change (2)
3.3	Certificate of Correction (2)
3.4	Articles of Merger (3)
3.5	Certificate of Correction (Articles of Merger) (3)
3.6	Certificate of Amendment to the Certificate of Incorporation (4)
3.7	Certificate of Incorporation (5)
4.1	Stock Option to acquire 500,000 shares of common stock issued to James Taylor dated May 25, 2011 (6)
4.5	Common Stock Purchase Warrant to acquire 500,000 shares of common stock issued to James Taylor dated May 25, 2011 (6)
4.6	Stock Option to acquire 500,000 shares of common stock issued to Stephen Burns dated May 25, 2011 (6)
4.7	Common Stock Purchase Warrant to acquire 500,000 shares of common stock issued to Stephen Burns dated May 25, 2011 (6)
4.8	Conversion Letter Agreement by and between Stephen Burns and AMP Holding Inc. (7)
4.9	Promissory Note in the principal amount of \$232,400 dated November 20, 2012 payable to EASi and Aerotek (8)
4.10	Form of Subscription Agreement by and between AMP Holding Inc. and the January 2013 Accredited Investor (9)
4.12	Form of Warrant by and between AMP Holding Inc. and the January 2013 Accredited Investor (9)
4.13	Promissory Note dated January 29, 2013 (9)
4.14	Common Stock Purchase Warrant issued to Stephen Baksa (10)
4.15	Secured Debenture by and between Workhorse Custom Chassis, LLC and AMP Trucks Inc. dated March 13, 2013 (11)
4.16	Security Agreement by and between Workhorse Custom Chassis, LLC and AMP Trucks Inc. dated March 13, 2013 (11)
4.17	Mortgage, Security Agreement, Assignment of Rents and Fixture Filing by and between Workhorse Custom Chassis, LLC and AMP Trucks Inc. dated March 13, 2013 (11)
4.18	Form of Subscription Agreement entered by and between AMP Holding Inc. and the March 2013 Accredited Investors (11)
4.19	Form of Common Stock issued to the March 2013 Accredited Investors (11)
4.20	2014 Incentive Stock Plan (12)
4.23	Subscription Agreement by and between AMP Holding, Inc. and Joseph T. Lukens (13)
4.24	Form of Common Stock Purchase issued to Joseph T. Lukens (13)
4.26	Form of Subscription Agreement entered between AMP Holding Inc. and the December 2014 Investors (20)
4.27	Form of 14% Unsecured Convertible Promissory Note issued to the December 2014 Investors (20)
4.28	Form of Common Stock Purchase Warrant issued to the December 2014 Investors (20)
4.29	Stock Option Agreement issued to James Taylor dated February 13, 2015 (21)
10.1	Share Exchange Agreement dated as of December 28, 2009 by and among Advanced Mechanical Products, Inc., the shareholders of Advanced Mechanical Products, Inc. and Title Starts Online, Inc. (1)

10.2	Director Agreement by and between AMP Holding Inc., and James E. Taylor dated October 11, 2010 (14)
10.3	Employment Agreement by and between AMP Holding Inc. and Stephen S. Burns dated December 8, 2010 (15)
10.4	Letter Agreement by and between AMP Holding Inc. and Martin J. Rucidlo dated August 24, 2012 (16)
10.17	Release and Settlement Agreement by and between ESG Automotive, Inc., AMP Holding Inc. and AMP Electric Vehicles Inc. (8)
10.18	Conversion Agreement by and between AMP Holding Inc. and an accredited investor dated February 21, 2013 (9)
10.19	Asset Purchase Agreement by and between Workhorse Custom Chassis, LLC, as Seller, and AMP Trucks Inc., as Buyer dated as of March 4, 2013 (11)
10.20	Amendment No. 1 to the Asset Purchase Agreement by and between Workhorse Custom Chassis, LLC, as Seller, and AMP Trucks Inc., as Buyer dated as of March 13, 2013 (11)
10.21	Employment Agreement between AMP Holding Inc. and Julio C. Rodriguez dated August 15, 2013 (17)
10.23	Director Agreement by and between AMP Holding Inc. and Raymond Chess dated October 24, 2013 (18)
10.24	Executive Employment Agreement entered between AMP Holding Inc. and Mashall S. Cogan dated February 13, 2015 (21)
10.25	Director Agreement entered between AMP Holding Inc. and Marshall S. Cogan dated February 13, 2015 (21)
10.26	Stock Option Agreement entered between AMP Holding Inc. and Marshall S. Cogan dated February 13, 2015 (21)
21.1	List of Subsidiaries (19)
23.1	Consent of Clark, Schaefer, Hackett & Co.
31.1	Certification of Chief Executive Officer pursuant to Rule 13a-14(a) or Rule 15d-14(a) as adopted pursuant to Section 302 of the Sarbanes-Oxley Act of 2002.
31.2	Certification of Chief Financial Officer pursuant to Rule 13a-14(a) or Rule 15d-14(a) as adopted pursuant to Section 302 of the Sarbanes-Oxley Act of 2002.
32.1	Certification of Chief Executive Officer pursuant to 18 U.S.C. Section 1350, as adopted pursuant to Section 906 of the Sarbanes-Oxley Act of 2002
32.2	Certification of Chief Financial Officer pursuant to 18 U.S.C. Section 1350, as adopted pursuant to Section 906 of the Sarbanes-Oxley Act of 2002

- (1) Incorporated by reference to the Form 8-K Current Report filed with the Securities and Exchange Commission on January 4, 2010.
- (2) Incorporated by reference to the Form 8-K Current Report filed with the Securities and Exchange Commission on May 25, 2010.
- (3) Incorporated by reference to the Form 8-K Current Report filed with the Securities and Exchange Commission on May 25, 2010.
- (4) Incorporated by reference to the Form 8-K Current Report filed with the Securities and Exchange Commission on September 10, 2010.
- (5) Incorporated by referenced to the Form SB-2 Registration Statement filed with the Securities and Exchange Commission on February 4, 2008.
- (6) Incorporated by reference to the Form 8-K Current Report filed with the Securities and Exchange Commission on June 1, 2011.
- (7) Incorporated by reference to the Form 8-K Current Report filed with the Securities and Exchange Commission on July 11, 2012.
- (8) Incorporated by reference to the Form 8-K Current Report filed with the Securities and Exchange Commission on January 11, 2013.
- (9) Incorporated by reference to the Form 8-K Current Report filed with the Securities and Exchange Commission on February 5, 2013.
- (10) Incorporated by reference to the Form 8-K Current Report filed with the Securities and Exchange Commission on February 28, 2013.
- (11) Incorporated by reference to the Form 8-K Current Report filed with the Securities and Exchange Commission on March 13, 2013.
- (12) Incorporated by reference to the Form S-8 Current Report filed with the Securities and Exchange Commission on January 17, 2014.
- (13) Incorporated by reference to the Form 8-K Current Report filed with the Securities and Exchange Commission on March 19, 2014.
- (14) Incorporated by reference to the Form 8-K Current Report filed with the Securities and Exchange Commission on October 19, 2010.
- (15) Incorporated by reference to the Form 8-K Current Report filed with the Securities and Exchange Commission on December 13, 2010.
- (16) Incorporated by reference to the Form 8-K Current Report filed with the Securities and Exchange Commission on August 30, 2012.
- (17) Incorporated by reference to the Form 8-K Current Report filed with the Securities and Exchange Commission on August 16, 2013.
- (18) Incorporated by reference to the Form 8-K Current Report filed with the Securities and Exchange Commission on October 30, 2013.
- (19) Incorporated by reference to the Form 10-K Annual Report filed with the Securities and Exchange Commission on April 15, 2014.
- (20) Incorporated by reference to the Form 8-K Current Report filed with the Securities and Exchange Commission on December 11, 2014.
- (21) Incorporated by reference to the Form 8-K Current Report filed with the Securities and Exchange Commission on February 19, 2015.

EX-101.INS XBRL INSTANCE DOCUMENT

EX-101.SCH XBRL TAXONOMY EXTENSION SCHEMA DOCUMENT

EX-101.CAL XBRL TAXONOMY EXTENSION CALCULATION LINKBASE

EX-101.DEF XBRL TAXONOMY EXTENSION DEFINITION LINKBASE

EX-101.LAB XBRL TAXONOMY EXTENSION LABELS LINKBASE

EX-101.PRE XBRL TAXONOMY EXTENSION PRESENTATION LINKBASE

Signatures

Pursuant to the requirements of Section 13 or 15(d) of the Securities and Exchange Act of 1934, the registrant has duly caused this report to be signed on its behalf by the undersigned hereunto duly authorized.

AMP HOLDING INC.

Dated: March 27, 2015

By: /s/Stephen S. Burns
Name: Stephen S. Burns
Title: Chief Executive Officer (Principal Executive Officer)

Dated: March 27, 2015

By: /s/Julio C. Rodriguez
Name: Julio C. Rodriguez
Title: Chief Financial Officer (Principal Financial and Accounting Officer)

In accordance with the Exchange Act, this report has been signed below by the following persons on March 27, 2015, on behalf of the registrant and in the capacities indicated.

<u>Signature</u>	<u>Title</u>
<u>/s/Stephen S. Burns</u> Stephen S. Burns	Chief Executive Officer and Director (Principal Executive Officer)
<u>/s/Julio C. Rodriguez</u> Julio C. Rodriguez	Interim Chief Financial Officer (Principal Financial Officer)
<u>/s/James E. Taylor</u> James E. Taylor	Director
<u>/s/Marshall S. Cogan</u> Marshall S. Cogan	Chairman of the Board of Directors and Chief Investment Officer

EXHIBIT 23.1

CONSENT OF INDEPENDENT AUDITORS

Board of Directors
AMP Holding Inc.

We consent to the incorporation by reference into the Form S-8 Registration Statement File No. 333-193425 of our report dated March 27, 2015 on our audits of the balance sheets of AMP Holding Inc. (A Development Stage Company) as of December 31, 2014 and 2013 and the related statements of operations, stockholders' equity (deficit), and cash flows for the years then ended and for the period from inception, February 20, 2007, to December 31, 2014 included in this Form 10-K.

/s/ Clark, Schaefer, Hackett & Co.

Cincinnati, Ohio
March 27, 2015

**CERTIFICATION OF PRINCIPAL EXECUTIVE OFFICER
PURSUANT TO SECTION 302 OF THE
SARBANES-OXLEY ACT OF 2002**

I, Stephen S. Burns, Chief Executive Officer, certify that:

1. I have reviewed this annual report on Form 10-K of AMP Holding Inc.;
2. Based on my knowledge, this annual report does not contain any untrue statement of a material fact or omit to state a material fact necessary to make the statements made, in light of the circumstances under which such statements were made, not misleading with respect to the period covered by this annual report;
3. Based on my knowledge, the financial statements, and other financial information included in this annual report, fairly present in all material respects the financial condition, results of operations and cash flows of the registrant as of, and for, the periods presented in this annual report;
4. The registrant's other certifying officers and I are responsible for establishing and maintaining disclosure controls and procedures (as defined in Exchange Act Rules 13a-15(e) and 15d-15(e)) and internal controls over financial reporting (as defined in Exchange Act Rules 13a-15(f) and 15d-15(f)) for the registrant) and have:
 - a) Designed such disclosure controls and procedures, or caused such disclosure controls and procedures to be designed under our supervision, to ensure that material information relating to the registrant, including its consolidated subsidiaries, is made known to us by others within those entities, particularly during the period in which this annual report is being prepared;
 - b) Designed such internal control over financial reporting, or caused such internal control over financial reporting to be designed under our supervision, to provide reasonable assurance regarding the reliability of financial reporting and the preparation of financial statements for external purposes in accordance with generally accepted accounting principles;
 - c) Evaluated the effectiveness of the registrant's disclosure controls and procedures and presented in this report our conclusions about the effectiveness of the disclosure controls and procedures, as of the end of the period covered by this report based on such evaluation; and
 - d) Disclosed in this report any change in the registrant's internal control over financial reporting that occurred during the registrant's most recent fiscal annual period that has materially affected, or is reasonably likely to materially affect, the registrant's internal control over financial reporting;
5. The registrant's other certifying officer and I have disclosed, based on our most recent evaluation of internal controls over financial reporting, to the registrant's auditors and the audit committee of registrant's board of directors (or persons performing the equivalent function):
 - a) All significant deficiencies and material weaknesses in the design or operation of internal controls over financial reporting which are reasonably likely to adversely affect the registrant's ability to record, process, summarize and report financial data information; and
 - b) Any fraud, whether or not material, that involves management or other employees who have a significant role in the registrant's internal controls over financial reporting.

Date: March 27, 2015

/s/Stephen S. Burns
Stephen S. Burns
Chief Executive Officer
(Principal Executive Officer)

**CERTIFICATION OF PRINCIPAL EXECUTIVE OFFICER
PURSUANT TO SECTION 302 OF THE
SARBANES-OXLEY ACT OF 2002**

I, Julio Rodriguez, Chief Financial Officer, certify that:

1. I have reviewed this annual report on Form 10-K of AMP Holding Inc.;
2. Based on my knowledge, this annual report does not contain any untrue statement of a material fact or omit to state a material fact necessary to make the statements made, in light of the circumstances under which such statements were made, not misleading with respect to the period covered by this annual report;
3. Based on my knowledge, the financial statements, and other financial information included in this annual report, fairly present in all material respects the financial condition, results of operations and cash flows of the registrant as of, and for, the periods presented in this annual report;
4. The registrant's other certifying officers and I are responsible for establishing and maintaining disclosure controls and procedures (as defined in Exchange Act Rules 13a-15(e) and 15d-15(e)) and internal controls over financial reporting (as defined in Exchange Act Rules 13a-15(f) and 15d-15(f)) for the registrant) and have:
 - a) Designed such disclosure controls and procedures, or caused such disclosure controls and procedures to be designed under our supervision, to ensure that material information relating to the registrant, including its consolidated subsidiaries, is made known to us by others within those entities, particularly during the period in which this annual report is being prepared;
 - b) Designed such internal control over financial reporting, or caused such internal control over financial reporting to be designed under our supervision, to provide reasonable assurance regarding the reliability of financial reporting and the preparation of financial statements for external purposes in accordance with generally accepted accounting principles;
 - c) Evaluated the effectiveness of the registrant's disclosure controls and procedures and presented in this report our conclusions about the effectiveness of the disclosure controls and procedures, as of the end of the period covered by this report based on such evaluation; and
 - d) Disclosed in this report any change in the registrant's internal control over financial reporting that occurred during the registrant's most recent fiscal annual period that has materially affected, or is reasonably likely to materially affect, the registrant's internal control over financial reporting;
5. The registrant's other certifying officer and I have disclosed, based on our most recent evaluation of internal controls over financial reporting, to the registrant's auditors and the audit committee of registrant's board of directors (or persons performing the equivalent function):
 - a) All significant deficiencies and material weaknesses in the design or operation of internal controls over financial reporting which are reasonably likely to adversely affect the registrant's ability to record, process, summarize and report financial data information; and
 - b) Any fraud, whether or not material, that involves management or other employees who have a significant role in the registrant's internal controls over financial reporting.

Date: March 27, 2015

/s/Julio Rodriguez
Julio Rodriguez
Chief Financial Officer
(Principal Financial Officer)

**CERTIFICATION PURSUANT TO
18 U.S.C. SECTION 1350,
AS ADOPTED PURSUANT TO**

SECTION 906 OF THE SARBANES-OXLEY ACT OF 2002

In connection with the Annual report of AMP Holding Inc. (the "Company") on Form 10-K for the period ending December 31, 2014 as filed with the Securities and Exchange Commission on the date hereof (the "Report"), I, Stephen S. Burns, Chief Executive Officer of the Company, certify, pursuant to 18 U.S.C. section 906 of the Sarbanes-Oxley Act of 2002, that:

- (1) The Report fully complies with the requirements of section 13(a) or 15(d) of the Securities and Exchange Act of 1934; and
- (2) The information contained in the Report fairly presents, in all material respects, the financial condition and results of operations of the Company.

Date: March 27, 2015

/s/Stephen S. Burns
Stephen S. Burns
Chief Executive Officer
(Principal Executive Officer)

**CERTIFICATION PURSUANT TO
18 U.S.C. SECTION 1350,
AS ADOPTED PURSUANT TO**

SECTION 906 OF THE SARBANES-OXLEY ACT OF 2002

In connection with the Annual report of AMP Holding Inc. (the "Company") on Form 10-K for the period ending December 31, 2014 as filed with the Securities and Exchange Commission on the date hereof (the "Report"), I, Julio Rodriguez, Chief Financial Officer of the Company, certify, pursuant to 18 U.S.C. section 906 of the Sarbanes-Oxley Act of 2002, that:

- (1) The Report fully complies with the requirements of section 13(a) or 15(d) of the Securities and Exchange Act of 1934; and
- (2) The information contained in the Report fairly presents, in all material respects, the financial condition and results of operations of the Company.

Date: March 27, 2015

/s/Julio Rodriguez

Julio Rodriguez

Chief Financial Officer

(Principal Financial Officer)