

UNITED STATES
SECURITIES AND EXCHANGE COMMISSION
WASHINGTON, D.C. 20549

FORM S-1
REGISTRATION STATEMENT
UNDER THE SECURITIES ACT OF 1933

AMP HOLDING INC.

(Exact name of registrant as specified in its charter)

Nevada

(State or other jurisdiction of
incorporation or organization)

3711

(Primary Standard Industrial
Classification Code Number)

26-1394771

(I.R.S. Employer
Identification Number)

**100 Commerce Drive
Loveland, Ohio 45140
513-360-4704**

(Address and telephone number of registrant's principal executive offices)

**Stephen S. Burns
Chief Executive Officer
AMP Holding Inc.
100 Commerce Drive
Loveland, Ohio 45140
513-360-4704**

(Name, address, including zip code, and telephone number, including area code, of agent for service)

Copies to:

Stephen M. Fleming
Fleming PLLC
49 Front Street, Suite 206
Rockville Centre, New York 11570
516-833-5034

Ralph V. De Martino
Cavas S. Pavri
Schiff Hardin LLP
901 K Street NW, Suite 700
Washington, DC 20001
202-778-6400

Approximate date of commencement of proposed sale to the public: As soon as practicable after the effective date of this registration statement.

If any of the securities being registered on this Form are to be offered on a delayed or continuous basis pursuant to Rule 415 under the Securities Act of 1933 check the following box:

If this Form is filed to register additional securities for an offering pursuant to Rule 462(b) under the Securities Act, please check the following box and list the Securities Act registration statement number of the earlier effective registration statement for the same offering.

If this Form is a post-effective amendment filed pursuant to Rule 462(c) under the Securities Act, check the following box and list the Securities Act registration statement number of the earlier effective registration statement for the same offering.

If this Form is a post-effective amendment filed pursuant to Rule 462(d) under the Securities Act, check the following box and list the Securities Act registration statement number of the earlier effective registration statement for the same offering.

Indicate by check mark whether the registrant is a large accelerated filer, an accelerated filer, a non-accelerated filer, or a smaller reporting company. See the definitions of "large accelerated filer," "accelerated filer" and "smaller reporting company" in Rule 12b-2 of the Exchange Act.

Large accelerated filer

Accelerated filer

Non-accelerated filer (Do not check if a smaller reporting company)

Smaller reporting company

The registrant is an "emerging growth company," as defined in Section 2(a) of the Securities Act. This registration statement complies with the requirements that apply to an issuer that is an emerging growth company.

CALCULATION OF REGISTRATION FEE

Title of Each Class of Securities to be Registered	Amount to be Registered	Proposed Maximum Offering Price Per Share	Proposed Maximum Aggregate Offering Price (1)	Amount of Registration Fee (2)
Units consisting of Common Stock and Series A Warrants				
Common Stock, par value \$0.001 per share, underlying the Units (5)	66,666,667 shares	\$ 0.15	\$ 10,000,000	\$ 1,162.00
Series A Warrants consisting of one half share of Common Stock, underlying the Units (3)	33,333,333 warrants	(3)	(3)	-
Common Stock underlying the Series A Warrants (5)	33,333,333 shares	\$ 0.15	\$ 5,000,000	\$ 581.00
Representative's Unit Purchase Option (3)		(3)	(3)	-
Common Stock underlying Units included in the Unit Purchase Option (4)	4,666,667 shares	\$ 0.15	\$ 700,000	\$ 81.34
Series A Warrants underlying Units included in the Unit Purchase Option	2,333,334 warrants	(3)	(3)	--
Common Stock underlying Series A Warrants included in the Units included in the Unit Purchase Option	2,333,334 shares	\$ 0.15	\$ 350,000	\$ 40.67
Total Registration Fee	-	-	<u>\$ 16,050,000</u>	<u>\$ 1,865.01</u>

- (1) Estimated solely for the purpose of computing the amount of the registration fee pursuant to Rule 457(o) under the Securities Act of 1933, as amended. Includes offering price of securities that the underwriters have the option to purchase to cover over-allotments, if any.
- (2) Calculated pursuant to Rule 457(o) based on an estimate of the proposed maximum aggregate offering price of the securities registered hereunder to be sold by the registrant.
- (3) No registration fee pursuant to Rule 457(g) under the Securities Act.
- (4) Estimated solely for the purposes of calculating the registration fee pursuant to Rule 457(g) under the Securities Act. The Representative's Warrants are exercisable at a per share exercise price equal to 100% of the public offering price. As estimated solely for the purpose of recalculating the registration fee pursuant to Rule 457(g) under the Securities Act, the proposed maximum aggregate offering price of the Representative's Warrant is \$700,000 (7% of \$10,000,000).

The registrant hereby amends this registration statement on such date or dates as may be necessary to delay its effective date until the registrant shall file a further amendment which specifically states that this registration statement shall thereafter become effective in accordance with Section 8(a) of the Securities Act of 1933 or until the registration statement shall become effective on such date as the Securities and Exchange Commission, acting pursuant to said Section 8(a), may determine.

The information in this preliminary prospectus is not complete and may be changed. We may not sell these securities until the registration statement filed with the Securities and Exchange Commission is effective. This prospectus is not an offer to sell these securities and we are not soliciting an offer to buy these securities in any state where the offer or sale is not permitted.

PRELIMINARY PROSPECTUS SUBJECT TO COMPLETION DATED , 2014



Units
Each Unit Consisting of One Share of Common Stock and
One-Half (0.5) of a Series A Warrant to Purchase One-Half (0.5) of a Share of Common Stock

This is a firm commitment initial public offering of the securities of AMP Holding Inc. We are offering _____ shares of common stock and _____ Series A Warrants. Each whole Series A Warrant is exercisable for one share of common stock. We expect that the initial public offering price for one unit consisting of one share and one-half (0.5) Series A Warrant will be between \$ _____ and \$ _____. Although issued together, the shares of common stock and Series A Warrants may be transferred separately immediately upon issuance.

Each whole Series A Warrant is exercisable for one share of common stock. A whole Series A Warrants is immediately exercisable upon issuance in this initial public offering at an initial exercise price of 100% of the initial public offering price of one unit in this offering. The Series A Warrants will expire on the fifth anniversary of the date of issuance. The shares of common stock issuable from time to time upon the exercise of the Series A Warrants are also being offered pursuant to this prospectus.

Our common stock is currently traded on the OTC Markets (OTCQB) under the symbol "AMPD". On December 10, 2014, the last reported sales price of our common stock was \$0.15 per share. We intend to change our name to Workhorse Advanced Vehicles Inc. and apply to list our common stock on the Nasdaq Capital Market (Nasdaq) under the symbol "WAV". The Series A Warrants will not be listed for trading on a securities exchange.

Before investing in our common stock and warrants exercisable for common stock, you should carefully read the discussion of "Risk Factors" beginning on page 7. Neither the Securities and Exchange Commission nor any state securities commission has approved or disapproved of these securities or determined if this prospectus is truthful or complete. Any representation to the contrary is a criminal offense.

	Per Unit	Total
Public offering price (1)	\$	\$
Underwriting discounts and commissions (2)	\$	\$
Offering proceeds to us, before expenses	\$	\$

(1) The price per unit of \$ _____ includes \$0.005 for each warrant to purchase 0.5 shares of common stock included in such unit.

(2) Does not include a non-accountable expense allowance equal to 1% of the gross proceeds of this offering payable to Dawson James Securities, Inc., the representative of the underwriters, or the issuance of a unit purchase option to acquire 7% of the units sold in this offering. See "Underwriting."

We have also granted a 45-day option to the representative of the underwriters to purchase up to (i) _____ additional shares of common stock, and (ii) additional Series A Warrants to purchase up to _____ additional shares of common stock solely to cover over-allotments, if any. The over-allotment option may be used to purchase shares of common stock and Series A Warrants, as determined by the underwriters, but such purchases cannot exceed an aggregate of 15% of the number of shares of common stock and Series A Warrants sold in the primary offering.

The underwriters expect to deliver our securities to purchasers in the offering on or about _____, 2015.

Sole Book Running Manager

Dawson James Securities, Inc.

TABLE OF CONTENTS

	<u>Page</u>
Prospectus Summary	1
The Offering	4
Summary Financial Data	6
Risk Factors	7
Cautionary Note Concerning Forward-Looking Statements	18
Use of Proceeds	19
Dividend Policy	20
Capitalization	21
Dilution	22
Selected Financial Data	24
Management’s Discussion and Analysis of Financial Condition and Results of Operations	26
Business	42
Management	80
Executive and Director Compensation	46
Certain Relationships and Related Person Transactions	48
Security Ownership of Certain Beneficial Owners and Management	50
Description of Certain Indebtedness	51
Description of Capital Stock	52
Shares Eligible for Future Sale	54
Material U.S. Federal Income Tax Considerations to U.S. Holders	56
Underwriting	59
Legal Matters	63
Experts	63
Where you Can Find More Information	63
Index to Financial Statements	F-1

We have not authorized anyone to provide any information or to make any representations other than those contained in this prospectus or in any free writing prospectus prepared by or on behalf of us or to which we have referred you. We take no responsibility for, and can provide no assurance as to the reliability of, any other information that others may give to you. The information contained in this prospectus is accurate only as of the date of this prospectus, regardless of the time of delivery of this prospectus or any sale of our common stock.

AMP’s logo and some of our trademarks, including the Workhorse ® are used in this prospectus. This prospectus also includes trademarks, trade names, and service marks that are the property of other organizations. Solely for convenience, our trademarks and trade names referred to in this prospectus appear without the ™ or the ® symbol, but those references are not intended to indicate, in any way, that we will not assert, to the fullest extent under applicable law, our rights, or the right of the applicable licensor to these trademarks and trade names.

This prospectus contains estimates, projections and other information concerning our industry, our business and the potential markets for our platform, including data regarding the estimated demand in those markets, their projected growth rates, as well as data regarding market research, estimates and forecasts prepared by our management. Information that is based on estimates, forecasts, projections, market research or similar methodologies is inherently subject to uncertainties and actual events or circumstances may differ materially from events and circumstances that are assumed in this information. Unless otherwise expressly stated, we obtained this industry, business, market and other data from reports, research surveys, studies and similar data prepared by market research firms and other third parties, industry, medical and general publications, government data and similar sources. While we believe these industry publications and third-party research, surveys and studies are reliable, we have not independently verified such data. In some cases, we do not expressly refer to the sources from which this data is derived. In that regard, when we refer to one or more sources of this type of data in any paragraph, you should assume that other data of this type appearing in the same paragraph is derived from the same sources, unless otherwise expressly stated or the context otherwise requires.

Unless the context requires otherwise references to “AMP Holding Inc.” “AMP Holding”, “Workhorse”, our “company,” “we,” “us” or “our” refer to AMP Holding Inc., a Nevada corporation, doing business as AMP Holding. We intend to change our name to Workhorse Advanced Vehicles Inc. AMP Holding primarily manages its operations through its two wholly owned subsidiaries, AMP Trucks Inc. (“AMP Trucks”), an Indiana corporation, and AMP Electric Vehicles Inc., an Ohio corporation (“AMP”).

Note Regarding Reverse Stock Split

As of _____ 2014, our Board intends to approve an amendment to our Articles of Incorporation to effect a reverse split of our common stock that we refer to as the Reverse Stock Split. Under NRS 78.207, the Board of Directors has the authority to reverse split the outstanding and authorized shares of common stock at an identical ratio solely based on the approval of the Board of Directors and without shareholder approval. Our Board is contemplating a Reverse Stock Split, at any time on or before _____ with the final ratio to be determined at the discretion of our Board. Unless we indicate otherwise, the information in this prospectus does not reflect the pro forma impact of the Reverse Stock Split.

PROSPECTUS SUMMARY

The following information is a summary of the prospectus and it does not contain all of the information you should consider before investing in our securities. You should read the entire prospectus carefully, including the "Risk Factors" section and our financial statements and the notes relating to the financial statements, before making an investment decision.

Our Company

Overview

AMP Holding Inc., which is in the process of changing its name to Workhorse Advanced Vehicles Inc., designs and produces high-performance electric vehicles (EVs) specifically engineered to enable our fleet customers to deliver goods and services with minimal environmental impact while reducing costs by 50% as compared to standard gas powered vehicles. Our new vehicles will be assembled at our 270,000 sq. ft. Indiana facility, which has a capacity to produce up to 60,000 complete chassis per year. Our medium duty vehicles come in two models: the Workhorse E-100 all-electric truck and the E-GEN™ electric truck with on board charging. Over the life of the vehicle, the Workhorse E-GEN™ potentially offers a savings of \$100,000, with the savings beginning immediately as compared to standard gas delivery vehicles, and a positive return on investment (ROI) by year three based on current gasoline and electricity costs. We believe these electric trucks represent the future of logistics by creating both economic and environmental benefits.

Customers

On June 16, 2014 we received an initial order for two E-GEN vehicles from a major transportation company that operates one of the world's largest fleets of delivery vehicles. The vehicles will be deployed by February 2015. This initial order was followed by a larger purchase agreement that Workhorse has entered into with this company to supply a total of 18 Workhorse E-100 all-electric walk in vans to be deployed in the Houston-Galveston-Brazoria, Texas area. The U.S. Department of Energy (DOE) National Energy Technology Laboratory awarded a grant to accelerate the introduction of electric vehicles to improve local air quality in the Houston-Galveston-Brazoria area, which is currently designated as a National Ambient Air Quality Non-Attainment Area.

Government Incentives

Our trucks qualify for financial incentives to lower the purchase price of an EV truck in states and cities including New York, California, and Chicago. Without these current incentives, our logistics solutions still offer a 50 % cost advantage as compared to traditional gas vehicles.

Market Size & Distribution Channels

In the market for electric logistics vehicles, we directly address the step van/strip chassis market. The market segments our vehicles serve include package and product delivery companies, uniform and laundry services, food services, utilities, and special-use industries. Companies operating in the space that are potential customers for AMP include UPS, FedEx, Bimbo Bakeries, Aramark, Canada Post, Cintas, Purolator, Peapod, UniFirst, and Frito Lay. We have sold our initial vehicles through our internal sales force but have the ability to sell our Workhorse vehicles through a distribution channel of approximately 440 dealers nationwide.

Vehicles

In addition to building its own chassis, AMP designs and produces two, second-generation, battery-electric drive trains both powered by Panasonic 18650 Li Ion cells. AMP's E-100 V.2 all electric drive train features a 100 kWh battery pack offering a range of up to 100 miles. AMP's E-GEN, introduced in 2014, is its newest drive train employing a 2200 nm permanent magnet electric drive motor coupled to a small internal combustion engine (ICE) that drives the electric motor in generator mode to keep the battery pack within the desired level of charge.

Market Entry

Based on market experience, we believe that the duty cycle of the average medium-duty local delivery truck market represents the appropriate entry point to launch electric trucks due to the quick financial payback associated with electrification. To our knowledge, our Workhorse E-GEN™ electric truck, which has an EPA approved on-board internal combustion engine, provides a three-year payback without any government financial incentives. Over the typical 10-year life of a medium-duty delivery truck, our Workhorse E-GEN electric truck is designed to save its owner over \$100,000 in fuel and maintenance savings, a projected 75% reduction in costs compared to gas powered vehicles based on current fuel and electricity costs.

Our Workhorse E-GEN electric truck is the first of its kind. Purpose-built for the package delivery vehicle market, it is expected to offer three-times the miles per gallon than typical gasoline-powered vans in use today. The E-GEN power train is unique in that it employs a 2200 nm permanent magnet motor/generator for propulsion plus a 2.4 Liter internal combustion engine that turns the electric motor in generator mode to recharge the battery pack under certain conditions i.e. the battery pack falls below a predetermined level, the vehicle is in park with the key out, and the emergency brake is on. As such, it can be charging while the driver stops the vehicle to make a delivery or pauses for lunch.

We believe the E-GEN will change the economics of EV acquisition by reducing battery costs, which in the past has been an impediment to the mass adoption of commercial EVs. By integrating Panasonic 18650 batteries with our proprietary battery management system, control software, charging innovations, and mechanical packaging, we are able to keep total vehicle cost at an attractive price point. At the same time, AMP is continually assessing battery technology and applications.

HorseFly™

Our unique HorseFly line of drones is designed to be the ‘last mile’ solution in delivery logistics. We worked with the University of Cincinnati to develop the HorseFly to meet the rigors of package delivery and to have eight rotors and redundant systems to ensure safety in the air. Today, we estimate that it costs approximately \$1 to move a 20,000-pound diesel-powered truck one mile. While we believe our Workhorse trucks can reduce the standard delivery costs from \$1 to less than \$0.30 cents per mile based on current costs of fuel, We expect that having drones handle the last leg of delivery could further potentially reduce the cost to about \$.03 cents for the last mile. The all weather HorseFly battery-powered drone will carry up to 10 pounds of cargo with a 15-mile range. It is designed to meet the anticipated FAA drone guidelines expected in 2015, of which there is no guarantee, and is differentiated from other drones as it is designed to work in tandem with a Workhorse electric truck. HorseFly will deliver packages, loaded on-route by the truck's driver, to remote locations while the driver continues on the main delivery route. HorseFly will then rejoin the truck at its new location after its delivery is completed, saving the fleet operator much of the time and fuel cost of the last, most expensive, mile. Also while the HorseFly is atop the Workhorse truck, it can quickly charge its batteries from the truck's large battery pack. We believe this implementation is superior to the proposed deployment of other delivery drones wherein the package is loaded at a distant warehouse and the drone must make a round trip flight to the delivery address and back to the warehouse. Other applications for the HorseFly include transmission line inspections and agricultural surveys.

Facilities

In March of 2013, we purchased the former Workhorse Custom Chassis assembly plant in Union City, Indiana from a subsidiary of Navistar International with the goal of transforming the company into the leading producer of electric medium duty trucks in the United States. To our knowledge, Workhorse Advanced Vehicles is the only commercial electric vehicle OEM in the country.

With the purchase we acquired a 220,000 sq. ft. factory, a 50,000 sq. ft. engineering facility, all the intellectual property and patents, and access to the 440 Workhorse dealers across the U.S., and established a supply agreement with its parts supplier UpTime parts. The mechanical, electrical and software design and engineering is done at our Cincinnati, Ohio headquarters. Ownership of this plant enables us to build new chassis with gross vehicle weight capacities of between 10,000 and 26,000 pounds and offer them with four different fuel variants—electric, gas, propane (LPG) and compressed natural gas (CNG).

Intellectual Property

We have six issued patents and two pending in the U.S. We also plan to pursue appropriate foreign patent protection. AMP also has five pending trademark applications and two issued trademark registrations in the U.S. with intent to pursue foreign trademark registration as well.

Competitive Landscape

We believe our ability to meet fleet performance specifications and reduce vehicle lifecycle costs affords us significant advantages over competing EVs. Other companies currently competing in the EV fleet logistics market include Ford Motor Company, Freightliner, Smith Electric Vehicles, and Electric Vehicles International. Batteries are the most expensive part of an EV. Workhorse uses Panasonic LI batteries; therefore our E-GEN battery packs are under \$20,000 since they can be recharged from the ICE, as compared to the industry's average battery pack cost of \$72,000. Competing EV trucks have limited range because they are electric only. Our EPA-approved E-GEN emergency range electric, medium-duty truck offers greater range since the truck can recharge when parked. As an OEM, our manufacturing costs are lower as compared to competitors that are installing their drive trains into chassis from another manufacturer.

Management Team

Our executive team has deep experience in the automotive industry, engineering field, and public company management. Our Chairman has 34 years of automotive and engineering management experience and was CEO of Hummer and General Manager of Cadillac. Our Founder and CEO is a veteran entrepreneur who has founded several successful start-ups, while our CFO has 35 years of financial management experience at several public companies. Our engineering executives are from Navistar, Autocar LLC, Procter and Gamble, and the United States Naval Research Lab.

Convertible Note Offering

From November 2014 through December 2014, we entered into Subscription Agreements with several accredited investors (the "2014 Investors") providing for the sale by us to the 2014 Investors of 14% Unsecured Convertible Promissory Notes in the aggregate amount of \$900,000 (the "2014 Notes"). In addition to the 2014 Notes, the 2014 Investors also received common stock purchase warrants (the "2014 Warrants") to acquire 3,214,286 shares of common stock. The 2014 Warrants are exercisable for five years at an exercise price of \$0.14. Dawson James acted as placement agent.

The 2014 Notes mature one year from their respective effective dates (the "Maturity Dates") and interest associated with the 2014 Notes is 14% per annum, which is payable on the Maturity Dates. The 2014 Notes are convertible into shares of common stock of the Company, at the 2014 Investors' option, at a conversion price of \$0.14. However, the 2014 Notes convert automatically upon our increasing our authorized shares of common stock to 500,000,000 shares of common stock or such other amount that would allow for the full conversion of the 2014 Notes. The 2014 Notes and the 2014 Warrants carry standard anti-dilution provisions and price protection provisions for a period of six months.

Our Corporate Information

We are a Nevada corporation headquartered in Loveland, Ohio that does business as AMP Holding Inc. utilizing the Workhorse® brand. Our manufacturing facility is located in Union City, Indiana. We were originally incorporated as Title Starts Online Inc. on November 13, 2007. On December 28, 2009, we entered into and closed a Share Exchange Agreement with the shareholders of AMP Electric Vehicles, Inc. pursuant to which we acquired 100% of the outstanding securities of AMP in exchange for 14,890,904 shares of our common stock. We formally changed our name to AMP Holding Inc. on May 24, 2010. On March 4, 2013, AMP Trucks Inc. ("AMP Trucks"), an Indiana corporation and a wholly-owned subsidiary of AMP Holding, entered into an Asset Purchase Agreement with Workhorse Custom Chassis, LLC ("Workhorse"), an Illinois limited liability company and a wholly-owned affiliate of Navistar International Corporation, to purchase certain assets including the Workhorse® brand, logo, intellectual property, patents and approximately 250,000 sq. ft. of facilities on 48 acres of land in Union City, Indiana (the "Workhorse Assets"). On March 13, 2013, AMP Trucks closed the acquisition of the Assets from Workhorse for a purchase price of \$5,000,000 of which \$2,750,000 was paid in cash and the delivery of a Secured Debenture (the "Workhorse Debenture") in the principal amount of \$2,250,000. The Workhorse Debenture is secured pursuant to a Security Agreement (the "Workhorse Security Agreement") and a Mortgage, Security Agreement, Assignment of Rents and Fixture Filing (the "Workhorse Mortgage") entered between AMP Trucks and Workhorse. Pursuant to the Security Agreement, AMP Trucks granted Workhorse a security interest in all of the assets of AMP Trucks in order to secure the prompt payment, performance and discharge in full of all of obligations of AMP Trucks under the Workhorse Debenture. Pursuant to the Workhorse Mortgage, the Workhorse Debenture is secured by the real estate and related assets of the plant located in Union City, Indiana. The Workhorse Debenture matures three years from its effective date of March 13, 2013 (the "Workhorse Maturity Date") and interest associated with the Debenture is 10% per annum, which is payable on the Maturity Date. AMP Trucks may prepay outstanding principal and interest of the Workhorse Debenture in full at any time. In the event AMP Trucks prepays outstanding principal and interest, it shall pay an amount equal to all outstanding principal and interest multiplied by 105%. AMP Holding and AMP guaranteed the payment of the Workhorse Debenture.

Our fiscal year ends December 31 of each year. Our principal executive offices are located at 100 Commerce Drive, Loveland, Ohio 45140. Our telephone number is 513-360-4704. Our website address is www.ampelectricvehicles.com. The information contained on, or that can be accessed through, our website is not incorporated by reference in this prospectus and should not be considered a part of this prospectus. We have included our website address in this prospectus solely as an inactive textual reference.

THE OFFERING

Securities we are offering	<p>units, with each unit consisting of one share of common stock and one-half (0.5) Series A Warrant to purchase one-half (0.5) share of common stock. The units will not be certificated and the shares of common stock and Series A Warrants may be transferred separately immediately upon issuance.</p> <p>Each Series A Warrant is exercisable for one-half share of common stock. A whole Series A Warrant is immediately exercisable upon issuance in this initial public offering at an initial exercise price of 100% of the initial public offering price of one unit in this offering. The Series A Warrants will expire on the fifth anniversary of the date of issuance.</p> <p>The shares of common stock issuable from time to time upon the exercise of the Series A Warrants are also being offered pursuant to this prospectus.</p>
Public offering price	\$ (the midpoint of the range set forth on the cover page of this prospectus) per unit.
Common stock outstanding before this offering	149,667,926 shares
Common stock included in the securities we are offering	(i) shares, which assumes no exercise of the Series A Warrants; or (ii) shares, which assumes the full exercise of the Series A Warrants.
Common stock to be outstanding immediately after this offering	shares, which assumes no exercise of the Series A Warrants.
Over-allotment option	We have granted a 45-day option to the representative of the underwriters to purchase up to (i) additional shares of common stock, and (ii) additional Series A Warrants, solely to cover over-allotments, if any. Such purchases cannot exceed an aggregate of 15% of the number of shares and Series A Warrants sold in the primary offering.
Use of proceeds	We estimate that the net proceeds from this offering will be approximately \$ million, or approximately \$ million if the underwriters exercise their over-allotment option in full, at an assumed initial public offering price of \$ per unit, (the midpoint of the range set forth on the cover page of this prospectus), after deducting the underwriting discounts and commissions and estimated offering expenses payable by us. We intend to use the net proceeds from this offering as follows: (i) approximately \$ million for developing our sales and service organization, (ii) approximately \$ million for research and development, (iii) approximately \$ million to finance capital expenditures, and (iv) the remaining proceeds, if any, will be used for general corporate purposes, including working capital. See “Use of Proceeds” for a more complete description of the intended use of proceeds from this offering.
Risk Factors	Investing in our securities involves substantial risks. You should read the “Risk Factors” section starting on page for a discussion of factors to consider carefully before deciding to invest in our securities.
Symbol	Our common stock is currently traded on the OTC Markets (OTCQB) under the symbol “AMPD”. On December 10, 2014, the last reported sales price of our common stock was \$0.15 per share. We intend to change our name to Workhorse Advanced Vehicles Inc. and apply to list our common stock on the Nasdaq Capital Market (Nasdaq) under the symbol “WAV”. The Series A Warrants will not be listed for trading on a securities exchange.

[TABLE OF CONTENTS](#)

The number of shares of our common stock outstanding before and after this offering, as set forth in the table above, is based on 149,667,926 shares outstanding as of November 20, 2014 and excludes as of that date:

- up to shares of common stock issuable upon the full exercise of the Series A Warrants offered hereby;
- 53,417,613 shares of common stock issuable upon the full exercise of warrants to purchase shares of common stock;
- 23,560,565 Options to purchase shares of our common stock issued under our 2010 Stock Incentive Plan, 2011 Stock Incentive Plan, 2012 Stock Incentive Plan, the 2013 Stock Incentive Plan and the 2014 Stock Incentive Plan.
- 5,104,750 shares of our common stock reserved for future issuance under our 2010 Stock Incentive Plan, 2011 Stock Incentive Plan, 2012 Stock Incentive Plan, the 2013 Stock Incentive Plan and the 2014 Stock Incentive Plan;
- 6,428,571 shares of common stock issuable upon exercise of the 14% unsecured convertible notes issued in November 2014 through December 2014;
- shares of our common stock underlying the warrants to be issued to the representative of the underwriters in connection with this offering, plus up to shares of our common stock if the over-allotment option to purchase shares of common stock is exercised in full; and
- the pro forma impact of the proposed Reverse Stock Split.

Unless otherwise indicated, all information in this prospectus:

- assumes no exercise of the representative's warrants described above;
- assumes no exercise of any outstanding options or warrants to purchase common stock;
- assumes no exercise by the representative of the underwriters of its option to purchase up to units consisting of (i) additional shares of common stock, and (ii) additional Series A Warrants to cover over-allotments, if any;
- does not reflect the pro forma impact of the proposed Reverse Stock Split.

SUMMARY FINANCIAL DATA

The summary financial data set forth below should be read in conjunction with our financial statements and the related notes, “Selected Financial Data” and “Management’s Discussion and Analysis of Financial Condition and Results of Operations” included elsewhere in this prospectus.

We derived the statement of operations data for the fiscal years ended December 31, 2012 and 2013 from our audited financial statements appearing elsewhere in this prospectus. We derived the statement of operations data for the nine months ended September 30, 2013 and 2014 and balance sheet data as of September 30, 2014 from our unaudited financial statements appearing elsewhere in this prospectus.

	Years Ended December 31,		Nine Months Ended September 30,	
	2012	2013	2013	2014
Consolidated Statements of Operations Data:				
Sales	\$ 272,098	\$ 177,500	\$ 177,500	\$ 177,459
Operating Expenses				
Selling, general and administrative	2,329,398	3,137,288	2,504,110	2,521,695
Research and development	1,984,302	2,892,505	2,285,637	2,364,686
Total operating expenses	4,313,700	6,029,793	4,789,746	4,886,381
Interest expense, net	230,887	258,261	179,029	92,218
Net loss during the development stage	\$ (4,272,489)	\$ (6,110,554)	\$ (4,791,275)	\$ (4,801,140)
Basic and diluted loss per share	\$ (0.10)	\$ (0.08)	\$ (0.07)	\$ (0.03)
Weighted average number of common shares outstanding	44,915,220	75,710,613	73,164,046	149,057,350

	As of December 31,		As of September 30, 2014	
	2012	2013	Actual	Pro Forma as Adjusted (1) (Unaudited)
Consolidated Balance Sheet Data:				
Cash and cash equivalents	39,819	7,019	833,834	
Property plant and equipment, net	126,847	4,407,261	4,112,685	
Working capital	(2,344,694)	(4,020,842)	(462,847)	
Total assets	220,693	4,850,997	5,410,234	
Long term debt, less current portion	362,186	2,292,890	2,495,244	
Common stock	55,955	82,712	149,051	
Additional paid in capital	14,956,547	20,321,536	26,992,044	
Stock based compensation	3,778,723	5,171,093	6,456,211	
Total stockholders' deficit	(21,371,258)	(27,481,812)	(32,442,712)	

- (1) The pro forma as adjusted balance sheet data above reflects the issuance of _____ shares of our common stock upon the completion of this offering at an assumed initial public offering price of \$ _____ per share (the mid-point of the price range on the front cover of this prospectus) after deducting estimated underwriting discounts and commissions and estimated offering expenses payable by us.

RISK FACTORS

An investment in our securities involves a high degree of risk. Before you invest in our securities, you should give careful consideration to the following risk factors, in addition to the other information included in this prospectus, including our financial statements and related notes, before deciding whether to invest in our securities. The occurrence of any of the adverse developments described in the following risk factors could materially and adversely harm our business, financial condition, results of operations or prospects. In that case, the trading price of our common stock could decline, and you may lose all or part of your investment.

Risks Related to Our Business and Industry

Our results of operations have not resulted in profitability and we may not be able to achieve profitability going forward.

We have incurred net losses amounting to \$32.4 million for the period from inception (February 20, 2007) through September 30, 2014. In addition, as of September 30, 2014, we had a working capital deficiency of \$462,000. We have had net losses in each quarter since our inception. We expect that we will continue to incur net losses for the foreseeable future. We may incur significant losses in the future for a number of reasons, including the other risks described in this prospectus, and we may encounter unforeseen expenses, difficulties, complications, delays and other unknown events. Accordingly, we may not be able to achieve or maintain profitability. Our management is developing plans to alleviate the negative trends and conditions described above and there is no guarantee that such plans will be successfully implemented. Our business plan has changed from concentrating on the electric passenger vehicle market to the electric medium duty trucks, but is still unproven. There is no assurance that even if we successfully implement our business plan, that we will be able to curtail our losses. Further, as we are a development stage enterprise, we expect that net losses and the working capital deficiency will continue. If we incur additional significant operating losses, our stock price may decline, perhaps significantly.

We have yet to achieve positive cash flow and, given our projected funding needs, our ability to generate positive cash flow is uncertain.

We have had negative cash flow from operating activities of \$2.7 million and \$2.2 million for the years ended December 31, 2013 and 2012 and \$2.9 million for the nine months ended September 30, 2014. We anticipate that we will continue to have negative cash flow from operating and investing activities for the foreseeable future as we expect to incur increased research and development, sales and marketing, and general and administrative expenses and make significant capital expenditures in our efforts to increase sales and commence operations at our Union City facility. Our business also will at times require significant amounts of working capital to support our growth, particularly as we acquire inventory to support our anticipated increase in production. An inability to generate positive cash flow for the foreseeable future may adversely affect our ability to raise needed capital for our business on reasonable terms, diminish supplier or customer willingness to enter into transactions with us, and have other adverse effects that may decrease our long-term viability. There can be no assurance we will achieve positive cash flow in the foreseeable future.

We may need access to additional financing, which may not be available to us on acceptable terms or at all. For the year ended December 31, 2013, our independent registered public accounting firm issued a report on our 2013 financial statements that contains an explanatory paragraph stating that the lack of sales, negative working capital and stockholders' deficit, raise substantial doubt about our ability to continue as a going concern. If we cannot access additional financing when we need it and on acceptable terms, our business, prospects, financial condition, operating results and ability to continue as a going concern could be adversely affected.

Our growth-oriented business plan to design, produce, sell and service commercial electric vehicles through our Union City facility will require continued capital investment. Our research and development activities will require continued investment. For the year ended December 31, 2013, our independent registered public accounting firm issued a report on our 2013 financial statements that contains an explanatory paragraph stating that the lack of sales, negative working capital and stockholders' deficit, raise substantial doubt about our ability to continue as a going concern. Assuming this offering does not close, we expect that our cash and cash equivalent balances, will be sufficient to fund our operating activities through January 31, 2015, which will not allow us to implement our business plan in any meaningful way. Based on an operating plan that assumes we receive net proceeds from this offering, we expect that our cash and cash equivalent balances and our anticipated cash from operating activities, will be sufficient to fund our operating activities, including the implementation of our business plan through 2016. However, if our operating costs exceed our expectations or if we incur any significant unplanned expenses, we may need to raise additional funds through the issuance of equity, equity-related or debt securities or by obtaining credit from government or financial institutions. This capital will be necessary to fund our ongoing operations, continue research, development and design efforts, open our sales, service and assembly facilities, improve infrastructure and introduce new or improve existing vehicle models. We cannot be certain that additional financing will be available to us on favorable terms when required, or at all, particularly given that we do not now have a committed credit facility with any government or financial institution. If we cannot obtain additional financing when we need it and on terms acceptable to us, our business, prospects, financial condition, operating results and ability to continue as a going concern could be adversely affected.

TABLE OF CONTENTS

Our limited operating history makes it difficult for us to evaluate our future business prospects and make decisions based on those estimates of our future performance.

We have basically been a research and development company since beginning operations in February 2007. We have a limited operating history and have generated limited revenue. As we move more toward a manufacturing environment it is difficult, if not impossible, to forecast our future results based upon our historical data. Because of the uncertainties related to our lack of historical operations, we may be hindered in our ability to anticipate and timely adapt to increases or decreases in revenues or expenses. If we make poor budgetary decisions as a result of unreliable historical data, we could be less profitable or incur losses, which may result in a decline in our stock price.

Failure to successfully integrate the Workhorse ® brand, logo, intellectual property, patents and assembly plant in Union City, Indiana into our operations could adversely affect our business and results of operations.

As part of our strategy to become an OEM, in March 2013, we acquired Workhorse and the Workhorse Assets including the Workhorse ® brand, logo, intellectual property, patents and assembly plant in Union City, Indiana. The Workhorse acquisition may expose us to operational challenges and risks, including the diversion of management's attention from our existing business, the failure to retain key Workhorse dealers and our ability to commence operations at the plant in Union City, Indiana. Our ability to sustain our growth and maintain our competitive position may be affected by our ability to successfully integrate the Workhorse Assets.

Our business, prospects, financial condition and operating results will be adversely affected if we cannot reduce and adequately control the costs and expenses associated with operating our business, including our material and production costs.

We incur significant costs and expenses related to procuring the materials, components and services required to develop and produce our electric vehicles. We have secured supply agreements for our critical components including our batteries. However, these are dependent on volume to ensure that they are available at a competitive price. As a result, our current cost projections are considerably higher than the projected revenue stream that such vehicles will produce. As a result we are continually working on initiatives to reduce our cost structure so that we may effectively compete. If we do not properly manage our costs and expenses our net losses will continue which will negatively impact our stock price.

If we are unable to pay off the outstanding amount owed under the debenture in the principal amount of \$2,250,000 that is secured against all of the assets of AMP Trucks including the Workhorse brand and the Union City facility and such lien holder were to take possession of such assets, our operations would be severely negatively impacted if not curtailed.

On March 4, 2013, AMP Trucks entered into an Asset Purchase Agreement with Workhorse Custom Chassis, LLC ("WCC"), an Illinois limited liability company and a wholly-owned affiliate of Navistar International Corporation, to purchase certain assets including the Workhorse ® brand, logo, intellectual property, patents and approximately 250,000 sq. ft. of facilities on 48 acres of land in Union City, Indiana (the "Assets"). On March 13, 2013, AMP Trucks closed the acquisition of the Assets from WCC for a purchase price of \$5,000,000 of which \$2,750,000 was paid in cash and the delivery of a Secured Debenture (the "Debenture") in the principal amount of \$2,250,000. The Debenture is secured pursuant to a Security Agreement (the "Security Agreement") and a Mortgage, Security Agreement, Assignment of Rents and Fixture Filing (the "Mortgage") entered between AMP Trucks and WCC. Pursuant to the Security Agreement, AMP Trucks granted WCC a security interest in all of the assets of AMP Trucks in order to secure the prompt payment, performance and discharge in full of all of obligations of AMP Trucks under the Debenture. Pursuant to the Mortgage, the Debenture is secured by the real estate and related assets of the plant located in Union City, Indiana. The Debenture matures three years from its effective date of March 13, 2013 (the "Maturity Date") and interest associated with the Debenture is 10% per annum, which is payable on the Maturity Date. AMP Trucks may prepay outstanding principal and interest of the Debenture in full at any time. In the event AMP Trucks prepays outstanding principal and interest, it shall pay an amount equal to all outstanding principal and interest multiplied by 105%. AMP Holding and AMP guaranteed the payment of the Debenture.

Our future growth is dependent upon the willingness of operators of commercial vehicle fleets to adopt electric vehicles and on our ability to produce, sell and service vehicles that meet their needs. If the market for commercial electric vehicles does not develop as we expect or develops more slowly than we expect, our business, prospects, financial condition and operating results will be adversely affected.

Our growth is dependent upon the adoption of electric vehicles by operators of commercial vehicle fleets and on our ability to produce, sell and service vehicles that meet their needs. The entry of commercial electric vehicles into the medium-duty commercial vehicle market is a relatively new development, particularly in the United States, and is characterized by rapidly changing technologies and evolving government regulation, industry standards and customer views of the merits of using electric vehicles in their businesses. This process has been slow as without including the impact of government or other subsidies and incentives, the purchase prices for our commercial electric vehicles currently is higher than the purchase prices for diesel-fueled vehicles. As part of our sales efforts, we must educate fleet managers as to the economical savings during the life of the vehicle. As such, we believe that operators of commercial vehicle fleets consider a number of factors when deciding whether to purchase our commercial electric vehicles (or commercial electric vehicles generally) or vehicles powered by internal combustion engines, particularly diesel-fueled or natural gas-fueled vehicles. We believe these factors include:

- the difference in the initial purchase prices of commercial electric vehicles and vehicles with comparable GVWs powered by internal combustion engines, both including and excluding the impact of government and other subsidies and incentives designed to promote the purchase of electric vehicles;



TABLE OF CONTENTS

- the total cost of ownership of the vehicle over its expected life, which includes the initial purchase price and ongoing operating and maintenance costs;
- the availability and terms of financing options for purchases of vehicles and, for commercial electric vehicles, financing options for battery systems;
- the availability of tax and other governmental incentives to purchase and operate electric vehicles and future regulations requiring increased use of nonpolluting vehicles;
- government regulations and economic incentives promoting fuel efficiency and alternate forms of energy;
- fuel prices, including volatility in the cost of diesel;
- the cost and availability of other alternatives to diesel fueled vehicles, such as vehicles powered by natural gas;
- corporate sustainability initiatives;
- commercial electric vehicle quality, performance and safety (particularly with respect to lithium-ion battery packs);
- the quality and availability of service for the vehicle, including the availability of replacement parts;
- the limited range over which commercial electric vehicles may be driven on a single battery charge;
- access to charging stations and related infrastructure costs, and standardization of electric vehicle charging systems;
- electric grid capacity and reliability; and
- macroeconomic factors.

If, in weighing these factors, operators of commercial vehicle fleets determine that there is not a compelling business justification for purchasing commercial electric vehicles, particularly those that we produce and sell, then the market for commercial electric vehicles may not develop as we expect or may develop more slowly than we expect, which would adversely affect our business, prospects, financial condition and operating results.

If our customers are unable to efficiently and effectively integrate our electric vehicles into their existing commercial fleets our sales may suffer and our business, prospects, financial condition and operating results may be adversely affected.

Our sales strategy involves a comprehensive plan for the pilot and roll-out of our electric vehicles, as well as the ongoing replacement of existing commercial vehicles with our electric vehicles, that is tailored to the individual needs of our customers. If we are unable to develop and execute fleet integration strategies or fleet management support services that meet our customers' unique circumstances with minimal disruption to their businesses, our customers may not realize the economic benefits they expect from our electric vehicles. If this were to occur, our customers may not order additional vehicles from us, which could adversely affect our business, prospects, financial condition and operating results.

We currently do not have long-term supply contracts with guaranteed pricing which exposes us to fluctuations in component, materials and equipment prices. Substantial increases in these prices would increase our operating costs and could adversely affect our business, prospects, financial condition and operating results.

Because we currently do not have long-term supply contracts with guaranteed pricing, we are subject to fluctuations in the prices of the raw materials, parts and components and equipment we use in the production of our vehicles. Substantial increases in the prices for such raw materials, components and equipment would increase our operating costs and could reduce our margins if we cannot recoup the increased costs through increased vehicle prices. Any attempts to increase the announced or expected prices of our vehicles in response to increased costs could be viewed negatively by our customers and could adversely affect our business, prospects, financial condition and operating results.

If we are unable to scale our operations at our Union City facility in an expedited manner from our limited low volume production to high volume production, our business, prospects, financial condition and operating results could be adversely affected.

We are currently assembling our orders at our Union City facility which is acceptable for our existing orders. In order to satisfy increased demand, we will need to quickly scale operations in our Union City facility as well as scale our supply chain including access to batteries. Our business, prospects, financial condition and operating results could be adversely affected if we experience disruptions in our supply chain, if we cannot obtain materials of sufficient quality at reasonable prices or if we are unable to scale our Union City facility.

We depend upon key personnel and need additional personnel.

Our success depends on the continuing services of James E. Taylor, Chairman of the Board, Stephen Burns, CEO, and Martin J. Rucidlo, President. On December 8, 2010, we entered into an employment agreement with Mr. Burns for a term of two years which automatically renews for one year periods unless either of the parties elects to not renew for such period. We entered into a letter agreement in August 2012 with Mr. Taylor whereby Mr. Taylor agreed to serve as the Chairman of the Board of Directors. Mr. Taylor may resign as a director any anytime. Mr. Rucidlo is not engaged under a long-term employment agreement. The loss of any of these individuals could have a material and adverse effect on our business operations. Additionally, the success of our operations will largely depend upon its ability to successfully attract and maintain competent and qualified key management personnel. As with any company with limited resources, there can be no guarantee that we will be able to attract such individuals or that the presence of such individuals will necessarily translate into profitability for our company. Our inability to attract and retain key personnel may materially and adversely affect our business operations. Any failure by our management to effectively anticipate, implement, and manage the changes required to sustain our growth would have a material adverse effect on our business, financial condition, and results of operations.

Our business requires substantial capital, and if we are unable to maintain adequate financing sources our profitability and financial condition will suffer and jeopardize our ability to continue operations.

We require substantial capital to support our operations. In order to fully implement our business plan, we expect that we will need approximately \$20,000,000 in capital through 2016. If we are unable to maintain adequate financing, or other sources of capital are not available, we could be forced to suspend, curtail or reduce our operations, which could harm our revenues, ability to achieve profitability, financial condition and business prospects.

We face competition. A few of our competitors have greater financial or other resources, longer operating histories and greater name recognition than we do and one or more of these competitors could use their greater resources and/or name recognition to gain market share at our expense or could make it very difficult for us to establish market share.

Companies currently competing in the fleet logistics market offering alternative fuel medium duty trucks include Ford Motor Company and Freightliner. In the electric medium duty truck market in the United States, we compete with a few other manufacturers, including Electric Vehicles International and Smith Electric Vehicles. Ford and Freightliner have more significant financial resources, established market positions, long-standing relationships with customers and dealers, and who have more significant name recognition, technical, marketing, sales, financial and other resources than we do. Ford and Freightliner are currently selling alternative fuel fleet vehicles including hybrids. The resources available to our competitors to develop new products and introduce them into the marketplace exceed the resources currently available to us. As a result, our competitors may be able to compete more aggressively and sustain that competition over a longer period of time that we can. This intense competitive environment may require us to make changes in our products, pricing, licensing, services, distribution, or marketing to develop a market position. Each of these competitors has the potential to capture market share in our target markets which could have an adverse effect on our position in our industry and on our business and operating results.

If we are unable to keep up with advances in electric vehicle technology, we may suffer a decline in our competitive position.

There are companies in the electric vehicle industry that have developed or are developing vehicles and technologies that compete or will compete with our vehicles. We cannot assure that our competitors will not be able to duplicate our technology or provide products and services similar to ours more efficiently. If for any reason we are unable to keep pace with changes in electric vehicle technology, particularly battery technology, our competitive position may be adversely affected. We plan to upgrade or adapt our vehicles and introduce new models in order to continue to provide electric vehicles that incorporate the latest technology. However, there is no assurance that our research and development efforts will keep pace with those of our competitors.

Our electric vehicles compete for market share with vehicles powered by other vehicle technologies that may prove to be more attractive than ours.

Our target market currently is serviced by manufacturers with existing customers and suppliers using proven and widely accepted fuel technologies. Additionally, our competitors are working on developing technologies that may be introduced in our target market. If any of these alternative technology vehicles can provide lower fuel costs, greater efficiencies, greater reliability or otherwise benefit from other factors resulting in an overall lower total cost of ownership, this may negatively affect the commercial success of our vehicles or make our vehicles uncompetitive or obsolete.

TABLE OF CONTENTS

We currently have a limited number of customers, with whom we do not have long-term agreements, and expect that a significant portion of our future sales will be from a limited number of customers and the loss of any of these high volume customers could materially harm our business.

A significant portion of our projected future revenue, if any, is generated from a limited number of vehicle customers. Additionally, much of our business model is focused on building relationships with large customers. Currently we have no contracts with customers that include long-term commitments or minimum volumes that ensure future sales of vehicles. As such, a customer may take actions that affect us for reasons that we cannot anticipate or control, such as reasons related to the customer's financial condition, changes in the customer's business strategy or operations or as the result of the perceived performance or cost-effectiveness of our vehicles. The loss of or a reduction in sales or anticipated sales to our most significant customers could have an adverse effect on our business, prospects, financial condition and operating results.

Changes in the market for electric vehicles could cause our products to become obsolete or lose popularity.

The modern electric vehicle industry is in its infancy and has experienced substantial change in the last few years. To date, demand for and interest in electric vehicles has been slower than forecasted by industry experts. As a result, growth in the electric vehicle industry depends on many factors, including, but not limited to:

- continued development of product technology, especially batteries
- the environmental consciousness of customers
- the ability of electric vehicles to successfully compete with vehicles powered by internal combustion engines
- limitation of widespread electricity shortages; and
- whether future regulation and legislation requiring increased use of non-polluting vehicles is enacted

We cannot assume that growth in the electric vehicle industry will continue. Our business may suffer if the electric vehicle industry does not grow or grows more slowly than it has in recent years or if we are unable to maintain the pace of industry demands.

The unavailability, reduction, elimination or adverse application of government subsidies, incentives and regulations could have an adverse effect on our business, prospects, financial condition and operating results.

We believe that, currently, the availability of government subsidies and incentives including those available in New York, California and Chicago is an important factor considered by our customers when purchasing our vehicles, and that our growth depends in part on the availability and amounts of these subsidies and incentives. Any reduction, elimination or discriminatory application of government subsidies and incentives because of budgetary challenges, policy changes, the reduced need for such subsidies and incentives due to the perceived success of electric vehicles or other reasons may result in the diminished price competitiveness of the alternative fuel vehicle industry.

We may be unable to keep up with changes in electric vehicle technology and, as a result, may suffer a decline in our competitive position.

Our current products are designed for use with, and are dependent upon, existing electric vehicle technology. As technologies change, we plan to upgrade or adapt our products in order to continue to provide products with the latest technology. However, our products may become obsolete or our research and development efforts may not be sufficient to adapt to changes in or to create the necessary technology. As a result, our potential inability to adapt and develop the necessary technology may harm our competitive position.

The failure of certain key suppliers to provide us with components could have a severe and negative impact upon our business.

We have secured supply agreements for our critical components including our batteries. However, these are dependent on volume to ensure that they are available at a competitive price. Further, we rely on a small group of suppliers to provide us with components for our products. If these suppliers become unwilling or unable to provide components or if we are unable to meet certain volume requirements in our existing supply agreements, there are a limited number of alternative suppliers who could provide them. Changes in business conditions, wars, governmental changes, and other factors beyond our control or which we do not presently anticipate could affect our ability to receive components from our suppliers. Further, it could be difficult to find replacement components if our current suppliers fail to provide the parts needed for these products. A failure by our major suppliers to provide these components could severely restrict our ability to manufacture our products and prevent us from fulfilling customer orders in a timely fashion.

Product liability or other claims could have a material adverse effect on our business.

The risk of product liability claims, product recalls, and associated adverse publicity is inherent in the manufacturing, marketing, and sale of electrical vehicles. Although we have product liability insurance for our consumer and commercial products, that insurance may be inadequate to cover all potential product claims. We also carry liability insurance on our products. Any product recall or lawsuit seeking significant monetary damages either in excess of our coverage, or outside of our coverage, may have a material adverse effect on our business and financial condition. We may not be able to secure additional product liability insurance coverage on acceptable terms or at reasonable costs when needed. A successful product liability claim against us could require us to pay a substantial monetary award. Moreover, a product recall could generate substantial negative publicity about our products and business and inhibit or prevent commercialization of other future product candidates. We cannot provide assurance that such claims and/or recalls will not be made in the

future.

We may have to devote substantial resources to implementing a retail product distribution network.

Dealers are often hesitant to provide their own financing to contribute to our product distribution network. As a result, we anticipate that we may have to provide financing or other consignment sale arrangements for dealers. A capital investment such as this presents many risks, foremost among them being that we may not realize a significant return on our investment if the network is not profitable. Our inability to collect receivables from dealers could cause us to suffer losses. Lastly, the amount of time that our management will need to devote to this project may divert them from performing other functions necessary to assure the success of our business.

Regulatory requirements may have a negative impact upon our business.

While our vehicles are subject to substantial regulation under federal, state, and local laws, we believe that our vehicles are or will be materially in compliance with all applicable laws. However, to the extent the laws change, or if we introduce new vehicles in the future, some or all of our vehicles may not comply with applicable federal, state, or local laws. Further, certain federal, state, and local laws and industrial standards currently regulate electrical and electronics equipment. Although standards for electric vehicles are not yet generally available or accepted as industry standards, our products may become subject to federal, state, and local regulation in the future. Compliance with these regulations could be burdensome, time consuming, and expensive.

Our products are subject to environmental and safety compliance with various federal and state regulations, including regulations promulgated by the EPA, NHTSA, and various state boards, and compliance certification is required for each new model year. The cost of these compliance activities and the delays and risks associated with obtaining approval can be substantial. The risks, delays, and expenses incurred in connection with such compliance could be substantial.

Our success may be dependent on protecting our intellectual property rights.

We rely on trade secret protections to protect our proprietary technology as well as several registered patents and one patent application. Our patents relate to the vehicle chassis assembly, vehicle header and drive module and manifold for electric motor drive assembly. Our existing patent application relates to the onboard generator drive system for electric vehicles. Our success will, in part, depend on our ability to obtain additional trademarks and patents. We are working on obtaining patents and trademarks registered with the United States Patent and Trademark Office but have not finalized any as of this date. Although we have entered into confidentiality agreements with our employees and consultants, we cannot be certain that others will not gain access to these trade secrets. Others may independently develop substantially equivalent proprietary information and techniques or otherwise gain access to our trade secrets.

We may be exposed to liability for infringing upon the intellectual property rights of other companies.

Our success will, in part, depend on our ability to operate without infringing on the proprietary rights of others. Although we have conducted searches and are not aware of any patents and trademarks which our products or their use might infringe, we cannot be certain that infringement has not or will not occur. We could incur substantial costs, in addition to the great amount of time lost, in defending any patent or trademark infringement suits or in asserting any patent or trademark rights, in a suit with another party.

Our electric vehicles make use of lithium-ion battery cells, which, if not appropriately managed and controlled, on rare occasions have been observed to catch fire or vent smoke and flames. If such events occur in our electric vehicles, we could face liability for damage or injury, adverse publicity and a potential safety recall, any of which could adversely affect our business, prospects, financial condition and operating results.

The battery packs in our electric vehicles use lithium-ion cells, which have been used for years in laptop computers and cell phones. On rare occasions, if not appropriately managed and controlled, lithium-ion cells can rapidly release the energy they contain by venting smoke and flames in a manner that can ignite nearby materials.

Our facilities could be damaged or adversely affected as a result of disasters or other unpredictable events. Any prolonged disruption in the operations of our facility would adversely affect our business, prospects, financial condition and operating results.

We engineer and assemble our electric vehicles in a facility in Loveland, Ohio and we intend to locate the assembly function to our facility in Union City. Any prolonged disruption in the operations of our facility, whether due to technical, information systems, communication networks, accidents, weather conditions or other natural disaster, or otherwise, whether short or long-term, would adversely affect our business, prospects, financial condition and operating results .

Risks Relating to Our Financial Position and Need for Additional Capital

Risks Related to Owning our Common Stock

An active trading market for our common stock may not develop, and you may not be able to sell your common stock at or above the initial public offering price.

Prior to the completion of this offering, there has been a limited public market for our common stock. Our common stock is currently traded on the OTC Markets (OTCQB) under the symbol “AMPD”. On December 10, 2014, the last reported sales price of our common stock was \$0.15 per share. We intend to change our name to Workhorse Advanced Vehicles Inc. and apply to list our common stock on the Nasdaq Capital Market (Nasdaq) under the symbol “WAV”. The Series A Warrants will not be listed for trading on a securities exchange. An active trading market for shares of our common stock may never develop or be sustained following this offering. If an active trading market does not develop, you may have difficulty selling your shares of common stock at an attractive price, or at all. The price for our common stock in this offering will be determined by negotiations among us and the underwriters, and it may not be indicative of prices that will prevail in the open market following this offering. Consequently, you may not be able to sell your common stock at or above the initial public offering price or at any other price or at the time that you would like to sell. An inactive market may also impair our ability to raise capital by selling our common stock, and it may impair our ability to attract and motivate our employees through equity incentive awards and our ability to acquire other companies, products or technologies by using our common stock as consideration.

The price of our common stock may fluctuate substantially.

You should consider an investment in our common stock to be risky, and you should invest in our common stock only if you can withstand a significant loss and wide fluctuations in the market value of your investment. Some factors that may cause the market price of our common stock to fluctuate, in addition to the other risks mentioned in this “Risk Factors” section and elsewhere in this prospectus, are:

- sales of our common stock by our stockholders, executives, and directors;
- volatility and limitations in trading volumes of our shares of common stock;
- fluctuations in our results of operations;
- our ability to develop significant sales;
- actual or un-anticipated fluctuations in our annual and quarterly financial results;
- our ability to obtain financings to continue and expand our commercial activities, commence our manufacturing operations at our Union City facility, maintain our competitive technological position and other business activities;
- our ability to secure resources and the necessary personnel to continue and expand our commercial activities;
- changes in our capital structure or dividend policy, including as a result of future issuances of securities and sales of large blocks of common stock by our stockholders;
- our cash position;
- announcements and events surrounding financing efforts, including debt and equity securities;
- reputational issues including issues relating to use of our vehicles by our customers;
- competition from traditional manufacturers utilizing diesel based engines and alternative fuels including electric or others that may emerge in the future;
- the absence of the development of a charging infrastructure;
- announcements of acquisitions, partnerships, collaborations, joint ventures, new diagnostic tests, capital commitments, or other events by us or our competitors;
- changes in general economic, political and market conditions in the United States;
- changes in industry conditions or perceptions;
- changes in valuations of similar companies or groups of companies;
- analyst research reports, recommendations and changes in recommendations, price targets and withdrawals of coverage;
- departures and additions of key personnel;

TABLE OF CONTENTS

- disputes and litigations related to intellectual properties, proprietary rights and contractual obligations;
- changes in applicable laws, rules, regulations, or accounting practices and other dynamics;
- release or expiry of lockup or other transfer restrictions on our outstanding common shares;
- announcements or actions taken by our principal stockholders; and
- other events or factors, many of which may be out of our control.

In addition, if the market for stocks in our industry or industries related to our industry, or the stock market in general, experiences a loss of investor confidence, the trading price of our common stock could decline for reasons unrelated to our business, financial condition and results of operations. If any of the foregoing occurs, it could cause our stock price to fall and may expose us to lawsuits that, even if unsuccessful, could be costly to defend and a distraction to management.

An effective registration statement may not be in place when an investor desires to exercise warrants, thus precluding such investor from being able to exercise his, her or its warrants at that time.

No warrant held by an investor will be exercisable and we will not be obligated to issue common stock unless at the time such holder seeks to exercise such warrant, a prospectus relating to the common stock issuable upon exercise of the warrant is current (or an exemption from registration is available) and the common stock has been registered or qualified or deemed to be exempt under the securities laws of the state of residence of the holder of the warrants. We cannot assure you that we will be able to maintain a current prospectus relating to the common stock issuable upon exercise of the warrants until the expiration of the warrants, and if we do not maintain a current prospectus related to the common stock issuable upon exercise of the warrants (and an exemption from registration is not available), holders will be unable to exercise their warrants and we will not be required to net cash settle any such warrant exercise. If we are unable to issue the shares upon exercise of the warrants by an investor because there is no current prospectus relating to the common stock issuable upon exercise of the warrant (and an exemption from registration is not available) or the common stock has not been registered or qualified or deemed to be exempt under the securities laws of the state of residence of the holder of the warrants, the warrants will not expire until ten days after the date we are first able to issue the shares. Nevertheless, because an investor may not be able to exercise the warrants at the most advantageous time, the warrants held by an investor may have no value, the market for such warrants may be limited and such warrants may expire worthless.

You will incur immediate dilution as a result of this offering.

If you purchase units in this offering, you will pay more for your shares than the net tangible book value of your shares. As a result, you will incur immediate dilution of \$ per share, representing the difference between the assumed initial public offering price of \$ per share (the midpoint of the range on the cover of this prospectus) and our estimated net tangible book value per share as of , 2014 of \$. Accordingly, should we be liquidated at our book value, you would not receive the full amount of your investment.

Future sales and issuances of our common stock or rights to purchase common stock pursuant to our equity incentive plan could result in additional dilution of the percentage ownership of our stockholders and could cause our share price to fall.

We expect that significant additional capital will be needed in the future to continue our planned operations, including expanding research and development, funding the production of our vehicles, purchasing of capital equipment, hiring new personnel, pursuing sales including developing our dealer network, and continuing activities as an operating public company. To the extent we raise additional capital by issuing equity securities, our stockholders may experience substantial dilution. We may sell common stock, convertible securities or other equity securities in one or more transactions at prices and in a manner we determine from time to time. If we sell common stock, convertible securities or other equity securities in more than one transaction, investors may be materially diluted by subsequent sales. Such sales may also result in material dilution to our existing stockholders, and new investors could gain rights superior to our existing stockholders.

Following the closing of this offering and our listing on NASDAQ, there is no guarantee that an active and liquid trading market will develop or that we will be able to continue to maintain our listing.

We will apply to list our shares of common stock trading on NASDAQ. Upon completion of this offering, we believe that we will satisfy the listing requirements and expect that our common stock will be listed on NASDAQ. Neither we nor the underwriters can provide any assurance that an active and liquid trading market in our common stock will develop or, if developed, that the market will continue. Our Board of Directors intends to implement a reverse stock split under NRS Section 78.207 in order to provide that we meet the minimum bid price. There is no guarantee that the reverse stock split will have the desired effect of providing that we satisfy the minimum bid price and, as a result, that we will commence trading on NASDAQ or that we will be able to continue to maintain our listing on NASDAQ.

[TABLE OF CONTENTS](#)

NASDAQ may delist our common stock from its exchange, which could limit investors' ability to make transactions in our common stock and subject us to additional trading restrictions.

Even after acceptance by NASDAQ, should we fail to satisfy the continued listing requirements of NASDAQ, such as the corporate governance requirements or the minimum closing bid price requirement, NASDAQ may take steps to delist our common stock. Such a delisting would likely have a negative effect on the price of our common stock and would impair your ability to sell or purchase our common stock when you wish to do so. In the event of a delisting, we would take actions to restore our compliance with NASDAQ's listing requirements, but we can provide no assurance that any such action taken by us would allow our common stock to become listed again, stabilize the market price or improve the liquidity of our common stock, prevent our common stock from dropping below the NASDAQ minimum bid price requirement or prevent future non-compliance with NASDAQ's listing requirements.

If NASDAQ does not maintain the listing of our securities for trading on its exchange, we could face significant material adverse consequences, including:

- a limited availability of market quotations for our securities;
- reduced liquidity with respect to our securities;
- a determination that our shares of common stock are "penny stock" which will require brokers trading in our shares of common stock to adhere to more stringent rules, possibly resulting in a reduced level of trading activity in the secondary trading market for our shares of common stock;
- a limited amount of news and analyst coverage for our company; and
- decreased ability to issue additional securities or obtain additional financing in the future.

Therefore, it may be difficult to sell any shares you purchase in this offering if you desire or need to sell them. Our lead underwriter, Dawson James Securities, Inc., or Dawson James, is not obligated to make a market in our common stock, and even after making a market, can discontinue market making at any time without notice.

The underwriter, Dawson James Securities, Inc. and persons associated with Dawson James Securities, Inc. will benefit from the completion of this offering because they hold warrants to purchase our common stock.

In connection with our private placement completed in December 2014 and as described elsewhere in this prospectus, Dawson James was issued an aggregate of (i) warrants to purchase a total of 289,286 shares of our common stock at \$0.14 per share and (ii) warrants to purchase a total of shares of our common stock at per share. Subject to waiver rights by Dawson James and other terms and conditions of the lock-up agreements, the holders of these warrants do not have the right to exercise the warrants for 180 days after the effective date of the registration statement of which this prospectus forms a part. The underwriter and its associates will benefit from the completion of this offering because of their ownership of these warrants, particularly if the warrants are exercisable or if they are exercised when the exercise price of the warrants is less than the market price of our stock.

Financial reporting obligations of being a public company in the United States are expensive and time consuming, and may place significant demands on our management and other personnel.

The additional obligations of being a public company in the United States require significant expenditures and may place significant demands on our management and other personnel, including costs resulting from public company reporting obligations under the Securities Exchange Act of 1934, as amended, or the Exchange Act, and the rules and regulations regarding corporate governance practices, including those under the Sarbanes-Oxley Act of 2002, or the Sarbanes-Oxley Act, the Dodd-Frank Wall Street Reform and Consumer Protection Act, or the Dodd-Frank Act, and the listing requirements of the stock exchange on which our securities are listed. Our management and other personnel will need to devote a substantial amount of time to ensure that we comply with all of these requirements. Any changes that we make to comply with these obligations may not be sufficient to allow us to satisfy our obligations as a public company on a timely basis, or at all.

We do not intend to pay cash dividends on our shares of common stock so any returns will be limited to the value of our shares.

We have never paid a cash dividend. We currently anticipate that we will retain future earnings for the development, operation and expansion of our business and do not anticipate declaring or paying any cash dividends for the foreseeable future. Any return to stockholders will therefore be limited to the increase, if any, of our share price.

Our management will be required to devote substantial time to compliance initiatives.

As a public company, we will incur significant legal, accounting and other expenses that we did not incur as a newly formed entity. The Sarbanes-Oxley Act of 2002, as well as rules subsequently implemented by the Securities and Exchange Commission, referred to herein as the SEC, and NASDAQ, have imposed various new requirements on public companies, including requiring establishment and maintenance of effective disclosure and financial controls and changes in corporate governance practices. Our management and other personnel will need to devote a substantial amount of time to these new compliance initiatives. Moreover, these rules and regulations will increase our legal and financial compliance costs and will make some activities more time consuming and costly. We expect these rules and regulations to make it more difficult and more expensive for us to obtain director and officer liability insurance and we may be required to incur substantial costs to maintain the same or similar coverage.

The dilutive effect of our warrants could have an adverse effect on the future market price of our ordinary shares or otherwise adversely affect the interests of our ordinary shareholders.

Based on outstanding warrants as of November 20, 2014, there will be outstanding warrants to purchase 53,417,617 of our common shares at a weighted average exercise price of \$0.83 per share upon completion of this offering. These warrants are likely to be exercised if the market price of our shares equals or exceeds the warrant exercise price. To the extent such warrants are exercised, additional shares will be issued, which would dilute the ownership of existing shareholders. Further, if the warrants are exercised at any time in the future at a price lower than the book value per share of our ordinary shares, existing shareholders could suffer dilution of their investment.

Provisions of our certificate of incorporation, our bylaws and Nevada law could make an acquisition of our Company, which may be beneficial to our stockholders, more difficult and may prevent attempts by our stockholders to replace or remove the current members of our board and management.

Certain provisions of our certificate of incorporation and bylaws could discourage, delay or prevent a merger, acquisition or other change of control that stockholders may consider favorable, including transactions in which you might otherwise receive a premium for your shares. Furthermore, these provisions could prevent or frustrate attempts by our stockholders to replace or remove members of our Board of Directors. These provisions also could limit the price that investors might be willing to pay in the future for our common stock, thereby depressing the market price of our common stock. Stockholders who wish to participate in these transactions may not have the opportunity to do so. These provisions:

- authorize our Board of Directors to issue without stockholder approval up to 75,000,000 shares of preferred stock, the rights of which will be determined at the discretion of the Board of Directors that, if issued, could operate as a “poison pill” to dilute the stock ownership of a potential hostile acquirer to prevent an acquisition that is not approved by our Board of Directors;
- require that stockholder actions must be effected at a duly called stockholder meeting or by unanimous written consent;
- establish advance notice requirements for stockholder nominations to our Board of Directors or for stockholder proposals that can be acted on at stockholder meetings;
- limit who may call stockholder meetings; and
- require the approval of the holders of a majority of the outstanding shares of our capital stock entitled to vote in order to amend certain provisions of our certificate of incorporation and bylaws.

In addition, we are governed by the corporate law of the State of Nevada, which may, unless certain criteria are met, prohibit large stockholders, in particular those owning 15% or more of the voting rights on our common stock, from merging or combining with us for a prescribed period of time.

Risks Associated with our Proposed Reverse Stock Split

The Board of Directors intends to reverse split the common stock and, if it is effected, may not achieve the benefits we intend and our total market capitalization may decrease following the reverse stock split.

As of 2014, our Board intends to approve an amendment to our Articles of Incorporation to effect a reverse split of our common stock which we refer to as the Reverse Stock Split. Under NRS 78.207, the Board of Directors has the authority to reverse split the outstanding and authorized shares of common stock at an identical ratio solely based on the approval of the Board of Directors and without shareholder approval. Our Board is contemplating a Reverse Stock Split, at any time on or before with the final ratio to be determined at the discretion of our Board. Unless we indicate otherwise, the information in this prospectus does not reflect the pro forma impact of the Reverse Stock Split. If we implement the Reverse Stock Split, there can be no assurance that the Reverse Stock Split, if completed, will achieve the benefits that we hope it will achieve. The total market capitalization of our common stock and the company after the Reverse Stock Split may be lower than the total market capitalization before the Reverse Stock Split. We will be subject to certain risks associated with it.

TABLE OF CONTENTS

We intend to effect a 1-for- Reverse Stock Split of our outstanding common stock prior to the date of this prospectus. However, the Reverse Stock Split may not increase our stock price sufficiently and we may not be able to list our common stock on the NASDAQ.

We expect that a 1-for- Reverse Stock Split of our outstanding common stock will increase the market price of our common stock so that we will be able to meet the minimum bid price requirement of the Listing Rules of the NASDAQ. However, the effect of a reverse stock split upon the market price of our common stock cannot be predicted with certainty, and the results of reverse stock splits by companies in similar circumstances have been varied. It is possible that the market price of our common stock following the Reverse Stock Split will not permit us to be in compliance with the applicable minimum bid or price requirements. If we are unable to meet the minimum bid or price requirements, we may be unable to list our shares on the NASDAQ.

Even if the Reverse Stock Split achieves the requisite increase in the market price of our common stock, we cannot assure you that we will be able to continue to comply with the minimum bid price requirement of the NASDAQ.

Even if the Reverse Stock Split achieves the requisite increase in the market price of our common stock to be in compliance with the minimum bid price of the NASDAQ, there can be no assurance that the market price of our common stock following the Reverse Stock Split will remain at the level required for continuing compliance with that requirement. It is not uncommon for the market price of a company's common stock to decline in the period following a reverse stock split. If the market price of our common stock declines following the effectuation of the Reverse Stock Split, the percentage decline may be greater than would occur in the absence of a Reverse Stock Split. In any event, other factors unrelated to the number of shares of our common stock outstanding, such as negative financial or operational results, could adversely affect the market price of our common stock and jeopardize our ability to meet or maintain the minimum bid price requirement of whichever exchange on which our common stock is listed. In addition to specific listing and maintenance standards, the NASDAQ have broad discretionary authority over the initial and continued listing of securities, which it could exercise with respect to the listing of our common stock.

CAUTIONARY NOTE CONCERNING FORWARD-LOOKING STATEMENTS

This prospectus contains forward-looking statements that involve risks and uncertainties. You should not place undue reliance on these forward-looking statements. Our actual results could differ materially from those anticipated in the forward-looking statements for many reasons, including the reasons described in our “Prospectus Summary,” “Use of Proceeds,” “Risk Factors,” “Management Discussion and Analysis of Financial Condition and Result of Operations,” and “Business” sections. In some cases, you can identify these forward-looking statements by terms such as “anticipate,” “believe,” “continue,” “could,” “depends,” “estimate,” “expects,” “intend,” “may,” “ongoing,” “plan,” “potential,” “predict,” “project,” “should,” “will,” “would” or the negative of those terms or other similar expressions, although not all forward-looking statements contain those words.

We have based these forward looking statements largely on our current expectations and projections about future events and financial trends that we believe may affect our financial condition, results of operations, business strategy and financial needs. These forward looking statements are subject to a number of known and unknown risks, uncertainties and assumptions, including risks described in the section titled “Risk Factors” and elsewhere in this prospectus, regarding, among other things:

- management and employee operations and execution risks;
- a failure to develop sales and the loss of any key customer that we may develop;
- loss of key personnel;
- competition in the markets we serve;
- intellectual property risks;
- our ability to fund our working capital requirements;
- risks associated with the uncertainty of future financial results;
- risks associated with this offering;
- risks associated with raising additional capital when needed and at reasonable terms; and
- risks associated with our reliance on third party suppliers of raw materials and other organizations that provide goods and services to us.

These risks are not exhaustive. Other sections of this prospectus may include additional factors that could adversely impact our business and financial performance. Moreover, we operate in a very competitive and rapidly changing environment. New risk factors emerge from time to time, and it is not possible for our management to predict all risk factors nor can we assess the impact of all factors on our business or the extent to which any factor, or combination of factors, may cause actual results to differ materially from those contained in, or implied by, any forward looking statements.

You should not rely upon forward looking statements as predictions of future events. We cannot assure you that the events and circumstances reflected in the forward looking statements will be achieved or occur. Although we believe that the expectations reflected in the forward looking statements are reasonable, we cannot guarantee future results, levels of activity, performance or achievements. Except as required by law, we undertake no obligation to update publicly any forward looking statements for any reason after the date of this prospectus or to conform these statements to actual results or to changes in our expectations.

You should read this prospectus and the documents that we reference in this prospectus and have filed as exhibits to the registration statement of which this prospectus is a part with the understanding that our actual future results, levels of activity, performance and achievements may be materially different from what we expect. We qualify all of our forward looking statements by these cautionary statements.

Industry and Market Data

This prospectus contains estimates and other statistical data made by independent parties and by us relating to market size and growth and other data about our industry. We obtained the industry and market data in this prospectus from our own research as well as from industry and general publications, surveys and studies conducted by third parties. This data involves a number of assumptions and limitations and contains projections and estimates of the future performance of the industries in which we operate that are subject to a high degree of uncertainty. We caution you not to give undue weight to such projections, assumptions and estimates. Further, industry and general publications, studies and surveys generally state that they have been obtained from sources believed to be reliable, although they do not guarantee the accuracy or completeness of such information. While we believe that these publications, studies and surveys are reliable, we have not independently verified the data contained in them. In addition, while we believe that the results and estimates from our internal research are reliable, such results and estimates have not been verified by any independent source.

USE OF PROCEEDS

We estimate that the net proceeds from our issuance and sale of _____ shares of our common stock in this offering will be approximately \$ _____ million, assuming an initial public offering price of \$ _____ per share, which is the midpoint of the price range listed on the cover page of this prospectus, after deducting estimated underwriting discounts and commissions and estimated offering expenses payable by us. If the underwriters exercise their over-allotment option in full, we estimate that the net proceeds from this offering will be approximately \$ _____ million.

A \$1.00 increase or decrease in the assumed initial public offering price of \$ _____ per share would increase or decrease the net proceeds from this offering by approximately \$ _____ million, assuming that the number of shares offered by us, as set forth on the cover page of this prospectus, remains the same and after deducting the estimated underwriting discounts and commissions.

We expect the net proceeds from this offering will allow us to fund our operations for up to _____ months following the closing of the offering. We intend to use the net proceeds from this offering as follows:

- (1) approximately \$ _____ million for developing our sales and service organization;
- (2) approximately \$ _____ million for research and development;
- (3) approximately \$ _____ million to finance capital expenditures; and
- (4) the remaining proceeds, if any, will be used for general corporate purposes, including working capital.

This expected use of net proceeds from this offering represents our intentions based upon our current plans and business conditions. The amounts and timing of our actual expenditures may vary significantly depending on numerous factors, including our ability to materially develop sales and our ability to obtain systems, components, raw materials, parts, manufacturing equipment and other supplies. As a result, our management will retain broad discretion over the allocation of the net proceeds from this offering. We may find it necessary or advisable to use the net proceeds from this offering for other purposes, and we will have broad discretion in the application of net proceeds from this offering. Furthermore, we anticipate that we will need to secure additional funding before we reach profitability.

Pending our use of the net proceeds from this offering, we intend to invest the net proceeds in a variety of capital preservation investments, including short-term, investment-grade, interest-bearing instruments and U.S. government securities.

DIVIDEND POLICY

We have never paid or declared any cash dividends on our common stock, and we do not anticipate paying any cash dividends on our common stock in the foreseeable future. We intend to retain all available funds and any future earnings to fund the development and expansion of our business. Any future determination to pay dividends will be at the discretion of our board of directors and will depend upon a number of factors, including our results of operations, financial condition, future prospects, contractual restrictions, restrictions imposed by applicable law and other factors our board of directors deems relevant. Our future ability to pay cash dividends on our stock may also be limited by the terms of any future debt or preferred securities or future credit facility.

CAPITALIZATION

The following table sets forth our unaudited capitalization as of September 30, 2014:

- on a pro forma basis to reflect (a) the receipt of net proceeds of \$900,000 after September 30, 2014 in consideration of the issuance of the 14% unsecured convertible notes; (b) the issuance of 6,428,571 shares of common stock upon conversion of the 14% unsecured convertible notes and 3,214,286 shares of common stock issuable upon exercise of the related common stock purchase warrants; and (c) the filing of our amended certificate of incorporation to increase our shares of common stock to 500,000,000; and
- on a pro forma as adjusted basis to give effect to our issuance and sale of _____ shares of our common stock included in the units being sold in this offering at the initial public offering price of \$ _____ per unit, which is the midpoint of the price range listed on the cover page of this prospectus, after deducting the underwriting discounts and commissions, and our estimated offering expenses.

	As of September 30, 2014		
	(unaudited)		
	Actual	Pro Forma	Pro Forma as Adjusted
	\$	\$	\$
Stockholders' equity (deficit) (1):			
Common stock, \$0.001 par value; 250,000,000 shares authorized; 149,057,350 shares issued and outstanding actual; _____ shares issued and outstanding pro forma; _____ shares issued and outstanding pro forma as adjusted	149,051		
Additional paid-in-capital	26,992,044		
Accumulated deficit	(32,442,712)		
Total stockholders' equity (deficit)	<u>1,154,594</u>		
Total capitalization	<u>5,410,234</u>	<u>\$</u>	<u>\$</u>

(1) The table above excludes, as of September 30, 2014:

- 17,152,389 shares of common stock issuable upon the exercise of options outstanding as of September 30, 2014 with a weighted average exercise price of \$0.22 per share;
- 49,914,041 shares of common stock issuable upon the exercise of outstanding warrants as of September 30, 2014, at a weighted average exercise price of \$0.83 per share;
- 5,104,750 shares of common stock reserved for future issuance under our 2010 Stock Incentive Plan, 2011 Stock Incentive Plan, 2012 Stock Incentive Plan, the 2013 Stock Incentive Plan and the 2014 Stock Incentive Plan;
- the pro forma impact of the proposed Reverse Stock Split.

You should read this table together with "Selected Financial Data," "Management's Discussion and Analysis of Financial Condition and Results of Operations" and our financial statements and the related notes appearing elsewhere in this prospectus.

DILUTION

If you invest in our securities, your ownership interest will be diluted to the extent of the difference between the initial public offering price per share of our common stock and the pro forma net tangible book value per share of our common stock after this offering. We calculate net tangible book value per share by dividing the net tangible book value, or tangible assets less total liabilities and preferred shares, by the number of outstanding shares of common stock.

Our historical net tangible book deficit as of September 30, 2014 was \$32,442,712 million or \$0.22 per share of common stock. Our pro forma net tangible book value at September 30, 2014 was \$, or \$ per share, based on 149,057,350 shares of our common stock outstanding as of September 30, 2014.

After giving effect to the sale of units by us at an assumed initial public offering price of \$ per share (the mid-point of the price range set forth on the front cover page of this prospectus), less the estimated underwriting discounts and commissions and our estimated offering expenses, our pro forma as adjusted net tangible book value at September 30, 2014 would be \$ million, or \$ per share. This amount represents an immediate increase in the pro forma net tangible book value of \$ per share to existing stockholders and an immediate dilution of \$ per share to new investors purchasing shares at an assumed initial public offering price of \$ per share.

The following table illustrates this dilution on a per share basis:

Assumed initial public offering price per share	\$
Actual net tangible deficit per share as of September 30, 2014	\$ 0.22
Pro forma increase per share attributable to conversion of 14% unsecured convertible promissory notes	
Pro forma net tangible book value per share as of September 30, 2014, before this offering	
Increase in pro forma net tangible book value per share attributable to new investors	
Pro forma as adjusted net tangible book value per share after this offering	
Dilution in pro forma net tangible book value per share to new investors	\$

A \$1.00 increase (decrease) in the assumed initial public offering price of \$ per share would increase (decrease) the pro forma net tangible book value by \$ million, the pro forma as adjusted net tangible book value per share after this offering by \$ per share and the dilution in pro forma net tangible book value per share to investors participating in this offering by \$ per share, assuming that the number of shares offered by us, as set forth on the cover page of this prospectus, remains the same and after deducting the estimated underwriting discounts and commissions and estimated offering expenses payable by us.

If the underwriters exercise in full their option to purchase additional units in this offering, the pro forma as adjusted net tangible book value per share after the offering would be \$ per share, the increase in the pro forma net tangible book value per share to existing stockholders would be \$ per share and the dilution to new investors purchasing common stock in this offering would be \$ per share.

TABLE OF CONTENTS

The following table shows on an adjusted pro forma basis at September 30, 2014, assuming 149,057,350 shares of our common stock outstanding after giving effect to the conversion of all 14% unsecured promissory notes into 6,428,571 shares of common stock, the difference between the number of shares of common stock purchased from us, the total consideration paid to us and the average price paid per share by existing stockholders and by new public investors purchasing common stock in this offering:

	Shares Purchased		Total Consideration		Average Price Per Share
	Number	Percent	Amount	Percent	
Existing stockholders		%	\$		% \$
New investors participating in this offering		%			% \$
Total		100%	\$	100%	\$

A \$1.00 increase (decrease) in the assumed initial public offering price of \$ per share (the mid-point of the price range set forth on the front cover page of this prospectus) would increase (decrease) the total consideration paid by new investors by \$ million, or increase (decrease) the percent of total consideration paid by new investors by %, assuming that the number of shares offered by us, as set forth on the cover page of this prospectus, remains the same.

If the underwriters exercise in full their option to purchase additional shares, sales by us in this offering will reduce the percentage of shares held by existing stockholders to % and will increase the number of shares held by new investors to , or %.

This information is based on 149,057,350 shares of common stock outstanding as of September 30, 2014, and assumes the conversion of all of our 14% unsecured convertible notes outstanding as of September 30, 2014 into 6,428,571 shares of common stock upon the completion of this offering and excludes:

- 17,152,389 shares of common stock issuable upon the exercise of options outstanding as of September 30, 2014 with a weighted average exercise price of \$0.22 per share;
- 49,914,041 shares of common stock issuable upon the exercise of outstanding warrants as of September 30, 2014, at a weighted average exercise price of \$0.83 per share;
- 5,104,750 shares of common stock reserved for future issuance under our 2010 Stock Incentive Plan, 2011 Stock Incentive Plan, 2012 Stock Incentive Plan, the 2013 Stock Incentive Plan and the 2014 Stock Incentive Plan;
- the pro forma impact of the proposed Reverse Stock Split.

To the extent these outstanding options or warrants are exercised there will be further dilution to the new investors.

Furthermore, we may choose to raise additional capital due to market conditions or strategic considerations even if we believe we have sufficient funds for our current or future operating plans. To the extent we issue additional shares of common stock or other equity or convertible debt securities in the future, there will be further dilution to investors participating in this offering.

If all our outstanding options and warrants noted above had been exercised, the pro forma net tangible book value as of September 30, 2014 would have been \$, or \$ per share, and the as adjusted pro forma net tangible book value after this offering would have been \$, or \$ per share, causing dilution to new investors of \$ per share. Additionally, assuming all outstanding options and warrants noted above had been exercised, the difference between the number of shares of common stock purchased from us, the total consideration paid to us, and the average price paid per share by existing stockholders and by new investors purchasing common stock in this offering would be as follows:

	Shares Purchased		Total Consideration		Average Price Per Share
	Number	Percent	Amount	Percent	
Existing stockholders		%	\$		% \$
New investors participating in this offering		%			% \$
Total		100%	\$	100%	\$

In addition, we may choose to raise additional capital due to market conditions or strategic considerations even if we believe we have sufficient funds for our current or future operating plans. To the extent that additional capital is raised through the sale of equity or convertible debt securities, the issuance of these securities may result in further dilution to our stockholders.

SELECTED FINANCIAL DATA

The following selected financial data should be read in conjunction with “Management’s Discussion and Analysis of Financial Condition and Results of Operations” and our financial statements and the related notes included elsewhere in this prospectus. The selected statement of operations data for the years ended December 31, 2012 and 2013 and selected balance sheet data as of December 31, 2012 and 2013 were derived from our audited financial statements that are included elsewhere in this prospectus. The selected statement of operations data for the nine months ended September 30, 2013 and 2014 and selected balance sheet data as of September 30, 2014 were derived from our unaudited financial statements that are included elsewhere in this prospectus. In the opinion of management, the unaudited financial statements were prepared on a basis consistent with our audited financial statements contained in this prospectus and include all adjustments necessary for the fair presentation of the financial information contained in those statements. The historical results presented below are not necessarily indicative of financial results to be achieved in future periods, and the results for the nine months ended September 30, 2014 are not necessarily indicative of results to be expected for the full year.

	Years Ended December 31,		Nine Months Ended September 30,	
	2012	2013	2013	2014
Consolidated Statements of Operations Data:				
Sales	\$ 272,098	\$ 177,500	\$ 177,500	\$ 177,459
Operating Expenses				
Selling, general and administrative	2,329,398	3,137,288	2,504,110	2,521,695
Research and development	1,984,302	2,892,505	2,285,637	2,364,686
Total operating expenses	4,313,700	6,029,793	4,789,746	4,886,381
Interest expense, net	230,887	258,261	179,029	92,218
Net loss during the development stage	\$ (4,272,489)	\$ (6,110,554)	\$ (4,791,275)	\$ (4,801,140)
Basic and diluted loss per share	\$ (0.10)	\$ (0.08)	\$ (0.07)	\$ (0.03)
Weighted average number of common shares outstanding	44,915,220	75,710,613	73,164,046	149,057,350

[TABLE OF CONTENTS](#)

	As of December 31,		As of September 30, 2014		
	2012	2013	Actual (1)	Pro Forma (2) (unaudited)	Pro Forma as Adjusted (3)
Assets					
Current assets:					
Cash and cash equivalents	39,819	7,019	833,834		
Inventory	41,002	392,750	392,750		
Prepaid expenses and deposits	13,025	43,967	70,965		
	<u>93,846</u>	<u>443,736</u>	<u>1,297,549</u>		
Property, plant and equipment net	<u>126,847</u>	<u>4,407,261</u>	<u>4,112,685</u>		
	<u>220,693</u>	<u>4,850,997</u>	<u>5,410,234</u>		
Liabilities and Stockholders' Equity (Deficit)					
Current liabilities:					
Accounts payable	1,253,228	1,546,388	1,369,206		
Accounts payable, related parties	336,556	468,165			
Customer deposits	60,000	177,500			
Shareholder advances	558,000	1,934,300			
Current portion of long-term debt	<u>230,756</u>	<u>338,225</u>	<u>37,548</u>		
	<u>2,438,540</u>	<u>4,464,578</u>	<u>1,760,396</u>		
Long-term debt	362,186	2,292,890	2,495,244		
Stockholders' equity (deficit):					
Series A preferred stock	-	-			
Common stock, par value of \$.001 per share	55,955	82,712	149,051		
Additional paid-in capital	14,956,547	20,321,536	26,992,044		
Stock based compensation	3,778,723	5,171,093	6,456,211		
Accumulated deficit during the development stage	<u>(21,371,258)</u>	<u>(27,481,812)</u>	<u>(32,442,712)</u>		
	<u>(2,580,033)</u>	<u>(1,906,471)</u>	<u>1,154,594</u>		
	<u>220,693</u>	<u>4,850,997</u>	<u>5,410,234</u>		

(1) Excludes net proceeds of \$900,000 from the sale of 14% unsecured convertible notes.

(2) Pro forma balance sheet data give effect to net proceeds of \$900,000 from the sale of 14% unsecured convertible promissory notes.

(3) The pro forma as adjusted balance sheet data above reflects the issuance of _____ shares of our common stock upon the completion of this offering at an assumed initial public offering price of \$ _____ per share (the mid-point of the price range on the front cover of this prospectus) after deducting estimated underwriting discounts and commissions and estimated offering expenses payable by us, as if this offering occurred on September 30, 2014.

MANAGEMENT'S DISCUSSION AND ANALYSIS OF FINANCIAL CONDITION AND RESULTS OF OPERATIONS

You should read the following discussion and analysis of our financial condition and results of operations together with "Selected Financial Data" and our financial statements and the related notes appearing elsewhere in this prospectus. In addition to historical information, this discussion and analysis contains forward-looking statements that involve risks, uncertainties and assumptions. Our actual results may differ materially from those discussed below. Factors that could cause or contribute to such differences include, but are not limited to, those identified below, and those discussed in the section titled "Risk Factors" included elsewhere in this prospectus. All amounts in this report are in U.S. dollars, unless otherwise noted.

Our Company

Overview

AMP Holding Inc., which is in the process of changing its name to Workhorse Advanced Vehicles Inc., designs and produces high-performance electric vehicles (EVs) specifically engineered to enable our fleet customers to deliver goods and services with minimal environmental impact while reducing costs by 50% as compared to standard gas powered vehicles. Our new vehicles will be assembled at our 270,000 sq. ft. Indiana facility, which has a capacity to produce up to 60,000 complete chassis per year. Our medium duty vehicles come in two models: the Workhorse E-100 all-electric truck and the E-GEN™ electric truck with on board charging. Over the life of the vehicle, the Workhorse E-GEN™ potentially offers a savings of \$100,000, with the savings beginning immediately as compared to standard gas delivery vehicles, and a positive return on investment (ROI) by year three based on current gasoline and electricity costs. We believe these electric trucks represent the future of logistics by creating both economic and environmental benefits.

Customers

On June 16, 2014 we received an initial order for two E-GEN vehicles from a major transportation company that operates one of the world's largest fleets of delivery vehicles. The vehicles will be deployed by February 2015. This initial order was followed by a larger purchase agreement that Workhorse has entered into with this company to supply a total of 18 Workhorse E-100 all-electric walk in vans to be deployed in the Houston-Galveston-Brazoria, Texas area. The U.S. Department of Energy (DOE) National Energy Technology Laboratory awarded a grant to accelerate the introduction of electric vehicles to improve local air quality in the Houston-Galveston-Brazoria area, which is currently designated as a National Ambient Air Quality Non-Attainment Area.

Vehicles

In addition to building its own chassis, AMP designs and produces two, second-generation, battery-electric drive trains both powered by Panasonic 18650 Li Ion cells. AMP's E-100 V.2 all electric drive train features a 100 kWh battery pack offering a range of up to 100 miles. AMP's E-GEN, introduced in 2014, is its newest drive train employing a 2200 nm permanent magnet electric drive motor coupled to a small internal combustion engine (ICE) that drives the electric motor in generator mode to keep the battery pack within the desired level of charge.

HorseFly™

Our unique HorseFly line of drones is designed to be the 'last mile' solution in delivery logistics. We worked with the University of Cincinnati to develop the HorseFly to meet the rigors of package delivery and to have eight rotors and redundant systems to ensure safety in the air. Today, we estimate that it costs approximately \$1 to move a 20,000-pound diesel-powered truck one mile. While we believe our Workhorse trucks can reduce the standard delivery costs from \$1 to less than \$0.30 cents per mile based on current costs of fuel, We expect that having drones handle the last leg of delivery could further potentially reduce the cost to about \$.03 cents for the last mile. The all weather HorseFly battery-powered drone will carry up to 10 pounds of cargo with a 15-mile range. It is designed to meet the anticipated FAA drone guidelines expected in 2015, of which there is no guarantee, and is differentiated from other drones as it is designed to work in tandem with a Workhorse electric truck. HorseFly will deliver packages, loaded on-route by the truck's driver, to remote locations while the driver continues on the main delivery route. HorseFly will then rejoin the truck at its new location after its delivery is completed, saving the fleet operator much of the time and fuel cost of the last, most expensive, mile. Also while the HorseFly is atop the Workhorse truck, it can quickly charge its batteries from the truck's large battery pack. We believe this implementation is superior to the proposed deployment of other delivery drones wherein the package is loaded at a distant warehouse and the drone must make a round trip flight to the delivery address and back to the warehouse. Other applications for the HorseFly include transmission line inspections and agricultural surveys.

Facilities

In March of 2013, we purchased the former Workhorse Custom Chassis assembly plant in Union City, Indiana from a subsidiary of Navistar International with the goal of transforming the company into the leading producer of electric medium duty trucks in the United States. To our knowledge, Workhorse Advanced Vehicles is the only commercial electric vehicle OEM in the country.

With the purchase we acquired a 220,000 sq. ft. factory, a 50,000 sq. ft. engineering facility, all the intellectual property and patents, and access to the 440 Workhorse dealers across the U.S., and established a supply agreement with its parts supplier UpTime parts. The mechanical, electrical and software design and engineering is done at our Cincinnati, Ohio headquarters. Ownership of this plant enables us to build new chassis with gross vehicle weight capacities of between 10,000 and 26,000 pounds and offer them with four different fuel variants—electric, gas, propane (LPG) and compressed natural gas (CNG).

Results of Operations

Three and Nine Months ended September 30, 2014 Compared to Three and Nine Months ended September 30, 2013

Our condensed consolidated statement of operations data for the period presented follows:

	Three Months Ended September 30		Nine Months Ended September 30	
	2014	2013	2014	2013
Sales	\$ -	\$ 177,500	\$ 177,459	\$ 177,500
Operating Expenses				
Selling, general and administrative	797,195	585,205	2,521,695	2,504,110
Research and development	895,669	562,425	2,364,686	2,285,637
Total operating expenses	1,692,864	1,147,630	4,886,381	4,789,746
Interest expense, net	95,001	75,034	251,978	179,029
Net loss during the development stage	<u>\$ (1,787,865)</u>	<u>\$ (1,045,164)</u>	<u>\$ (4,960,900)</u>	<u>\$ (4,791,275)</u>

Revenue

We generated revenue of \$177,000 for the nine months ended September 30, 2014 for the delivery of an all-electric Para-transit 12 passenger bus to BARTA (Berks County Regional Transit Authority) of Pennsylvania. We generated revenue of \$177,000 for the nine months ended September 30, 2013 for half of the order to BARTA delivered during 2013.

We have received two orders totaling 18 vehicles from a major transportation company which we are in the process of filling and that we expect to deliver in the next 12 months.

Selling, General and Administrative Expenses

Selling, general and administrative expenses consist primarily of personnel and facilities costs related to our development including, marketing, sales, executive, finance, human resources, information technology and professional, legal and contract services.

Selling, general and administrative expenses during the three and nine months ended September 30, 2014 were \$797,000 and \$2.5 million, respectively, an increase from \$585,000 and \$2.5 million from the three months and nine month ended September 30, 2013, respectively. The \$212,000 increase in the three months ended in September 30, 2014 is mainly due to additions in employee expenses, and stock based compensation as a result of increased activity in the building of new customer orders. The \$17,000 increase in the nine months ended September 30, 2014 is due higher levels of expense mainly in stock based compensation.

Research and Development Expenses

Research and development expenses consist primarily of personnel costs for our teams in engineering and research, prototyping expense, and contract and professional services. Union City plant expenses prior to the start of production are also included in research and development expenses.

[TABLE OF CONTENTS](#)

Research and development expenses during the three months and nine ended in September 30, 2014 were approximately \$896,000 and \$2.4 million, respectively, an increase from \$562,000 and \$2.3 million for the three and nine months ended September 30, 2013, respectively. The \$333 increase for the three months ended in September 30, 2014 is the result of higher engineering consulting expense as well as increments in motors and batteries for E-Gen prototypes. The \$79,000 increase for the nine months ended in September 30, 2013 is mainly the effect of increased prototype activities compared to last year.

Interest Expenses

Our interest expense is incurred primarily from our long term loan with Navistar in connection to the purchase of the Union City plant mentioned before in the Property, Plant and Equipment and Long Term Loan notes to the financial statements.

Interest expenses during the three and nine months ended in September 30, 2014 were approximately \$95,000 thousand and \$252,000 respectively, an increase from \$75,000 and \$179,000 during the three and nine months ended in September 30, 2013, respectively. The \$20,000 and \$74,000 increase was mainly due to the fact that we had just completed the purchase during the month of March 2013 so no interests needed to be accrued early in that quarter. Also interests on the loan are capitalized to the principal and payable after three years and we capitalized the first year of interests in March 2014.

Year Ended December 31, 2013 Compared to Year Ended December 31, 2012

Revenue

Revenue was \$177,500 for the year ended December 31, 2013 for the all-electric Para-transit 12 passenger bus to BARTA mentioned above. Revenue was \$272,098 for the year ended December 31, 2012 and consisted of a limited number of customer passenger vehicle conversions which we are no longer actively engaged.

Expenses

Our expenses for the year ended December 31, 2013 were \$6,288,053 and included payroll and payroll taxes (\$1,527,952), stock based compensation (\$1,392,370), consulting (\$1,088,818) legal and professional (\$441,439), interests (\$258,261), and batteries, motors and supplies and vehicle testing (\$397,617). Our expenses for the year ended December 31, 2012 were \$4,544,587 and included payroll and payroll taxes (\$1,773,232), stock based compensation (\$338,853), legal and professional (\$709,883), advertising (\$429,483), and batteries, motors and supplies (\$240,907). The major reasons for the increase in comparing the year ended 2013 to 2012 was primarily related to non-cash payments for consulting fees associated with the Workhorse Plant acquisition and plant expenses as well as the development of the new Gen II and E-Gen technologies.

Net loss

Net loss for the years ended December 31, 2013 and 2012 were \$6,110,554 and \$4,272,489, respectively.

Liquidity and Capital Resources

Summary of Cash Flows

	Three Months Ended September 30		Nine Months Ended September 30	
	2014	2013	2014	2013
Net cash used in operating activities	(963,231)	(730,923)	(2,857,862)	(2,235,170)
Net cash used in investing activities	-	(63)	-	(2,750,063)
Net cash provided by financing activities	(9,111)	592,911	3,684,677	4,952,877

TABLE OF CONTENTS

Cash Flows from Operating Activities

Our cash flows from operating activities are affected by our cash investments to support the business in research and development, manufacturing, selling, general and administrative. Our operating cash flows are also affected by our working capital needs to support fluctuations in inventory, personnel expenses, accounts payable and other current assets and liabilities.

Net cash used in operating activities was \$2.9 million during the nine months ended September 30, 2014. The largest component of our cash used during this was to our net loss of \$5 million, which included non-cash charges such as depreciation of \$295,000, stock based compensation of \$1.3 million, consulting services paid in stock of \$795,000, capitalization of accrued interests of \$225,000 on the Navistar long term loan and increase in accounts payable of \$452,000. Operating cash outflows for the nine months ended September 30, 2014 were primarily related to research and development expenses of \$2.5 million and operating expenses of \$2.5 million, in addition to payment of accounts payable for related parties for \$756,000.

Net cash used in operating activities was \$2.2 million during the nine months ended September 30, 2013. The main component of our cash used during this periods related to our net loss of \$4.8 million, which included non-cash charges such as depreciation of \$218,000, stock based compensation of \$1.2 million and consulting services paid in stock of \$860,000. Operating cash outflows for the nine months ended September 30, 2014 were primarily related to research and development expenses of \$2.2 million and operating expenses of \$2.5 million, partially offset by \$142,000 increase in customer deposits and \$159,000 in accounts payable.

Cash Flows from Investing Activities

Cash flow from investing activities primarily relates to capital expenditures to support our future growth in operations including the investments made in the Union City plant.

There was no cash used in investing activities during the nine months ended September 30, 2014. The \$2.7 million used during the nine months ended in September 30, 2013 were mainly invested in the Union City Plant purchase.

Cash Flows from Financing Activities

Net cash provided by financing activities was \$4.9 million during the nine months ended September 30, 2014 and was comprised primarily of \$4 million net of issuance of common stock offset by payments of \$323 thousand for long term debt.

Net cash provided by financing activities was \$7.2 million during the nine months ended September 30, 2013 and was comprised primarily of \$4.3 million of issuance of common stock and the increase of long term debt of \$2.25 million for the loan to Navistar for the purchase of the Union City plant.

Off-Balance Sheet Arrangements

The Company does not have any off-balance sheet arrangements that have or are reasonably likely to have a current or future effect on the Company's financial condition, changes in financial condition, revenues or expenses, results of operations, liquidity, capital expenditures or capital resources that are material to investors.

Federal Tax Credit Qualification by the IRS & Select State Incentive Programs

The Company has been qualified by the IRS for a vehicle federal tax credit of up to \$7,500. The Company joins a list of plug-in electric drive motor vehicle manufacturers, including Ford Motor Company, General Motors Corporation, Tesla, Toyota, and 13 EV manufacturers in all, qualifying purchasers for up to a \$7,500 tax credit when purchasing an electric vehicle. In September 2013, California HVIP approved the AMP E-100 truck for a minimum point of purchase voucher of \$90,000 per vehicle purchased. On August 9, 2013 NYSEDA the New York State point of purchase voucher program approved the AMP E-100 for an incentive of \$60,000 per vehicle. Drive Clean Chicago recently approved vouchers of \$60,000 for the AMP E-100 and \$32,800 for the AMP E-GEN.

Critical Accounting Policies

We consider accounting policies involving significant judgments and assumptions by management that have, or could have, a material impact on the carrying value of certain assets or on income (loss) to be critical accounting policies. We consider the following to be our critical accounting policies: basis of presentation, development-stage Company, revenue recognition, and income taxes.

Quantitative and Qualitative Disclosures About Market Risk

We are exposed to market risk in the ordinary course of our business. We do not hold or issue financial instruments for trading purposes. Market risk represents the risk of loss that may impact our financial position due to adverse changes in financial market prices and rates. Our market exposure is primarily a result of fluctuations in interest rates, however, we do not believe there is material exposure to interest rate risk. We also do not believe we are exposed to material risk resulting from fluctuations in foreign currency exchange rates due to (a) the level of our international sales, which comprised 3.2% and 3.0% of our total revenues during the year ended December 31, 2013 and the six month period ended September 30, 2014, respectively and (b) our current practice of conducting international sales in U.S. dollars.

Controls and Procedures

Internal control over financial reporting is a process designed to provide reasonable assurance regarding the reliability of financial reporting and the preparation of financial statements in accordance with U.S. GAAP. We have identified material weaknesses in our internal control over financial reporting relating to the processes and controls to properly identify and account for transactions of a complex or non-routine nature and the process and controls of our period closing procedures. We are currently in the process of reviewing, documenting and testing our internal control over financial reporting. Although remediation efforts are still in progress, management is taking steps to address the causes of our audit adjustments and to improve our internal control over financial reporting, including the implementation of new accounting processes and control procedures and the identification of gaps in our skills base and expertise of the staff required to meet the financial reporting requirements of a public company. For example, in October of 2013 we hired accounting consultants to provide the necessary staffing and we intend to continue to work with these consultants as we hire qualified permanent employees. We have not engaged an independent registered public accounting firm to perform an audit of our internal control over financial reporting as of any balance sheet date or for any period reported in our financial statements.

BUSINESS

Unless the context requires otherwise references to “AMP Holding Inc.” “AMP Holding”, our “company,” “we,” “us” or “our” refer to AMP Holding Inc., a Nevada corporation, doing business as AMP Holding. AMP Holding primarily manages its operations through its two wholly-owned subsidiaries, AMP Trucks Inc. (“AMP Trucks”), an Indiana corporation, and AMP Electric Vehicles Inc., an Ohio corporation (“AMP”).

Our Company

Overview

AMP Holding Inc., which is in the process of changing its name to Workhorse Advanced Vehicles Inc., designs and produces high-performance electric vehicles (EVs) specifically engineered to enable our fleet customers to deliver goods and services with minimal environmental impact while reducing costs by 50% as compared to standard gas powered vehicles. Our new vehicles will be assembled at our 270,000 sq. ft. Indiana facility, which has a capacity to produce up to 60,000 complete chassis per year. Our medium duty vehicles come in two models: the Workhorse E-100 all-electric truck and the E-GEN™ electric truck with on board charging. Over the life of the vehicle, the Workhorse E-GEN™ potentially offers a savings of \$100,000, with the savings beginning immediately as compared to standard gas delivery vehicles, and a positive return on investment (ROI) by year three based on current gasoline and electricity costs. We believe these electric trucks represent the future of logistics by creating both economic and environmental benefits.

Customers

On June 16, 2014 we received an initial order for two E-GEN vehicles from a major transportation company that operates one of the world’s largest fleets of delivery vehicles. The vehicles will be deployed by February 2015. This initial order was followed by a larger purchase agreement that Workhorse has entered into with this company to supply a total of 18 Workhorse E-100 all-electric walk in vans to be deployed in the Houston-Galveston-Brazoria, Texas area. The U.S. Department of Energy (DOE) National Energy Technology Laboratory awarded a grant to accelerate the introduction of electric vehicles to improve local air quality in the Houston-Galveston-Brazoria area, which is currently designated as a National Ambient Air Quality Non-Attainment Area.

Government Incentives

Our trucks qualify for financial incentives to lower the purchase price of an EV truck in states and cities including New York, California, and Chicago. Without these current incentives, our logistics solutions still offer a 50 % cost advantage as compared to traditional gas vehicles.

Market Size & Distribution Channels

In the market for electric logistics vehicles, we directly address the step van/strip chassis market. The market segments our vehicles serve include package and product delivery companies, uniform and laundry services, food services, utilities, and special-use industries. Companies operating in the space that are potential customers for AMP include UPS, FedEx, Bimbo Bakeries, Aramark, Canada Post, Cintas, Purolator, Peapod, UniFirst, and Frito Lay. We have sold our initial vehicles through our internal sales force but have the ability to sell our Workhorse vehicles through a distribution channel of approximately 440 dealers nationwide.

Vehicles

In addition to building its own chassis, AMP designs and produces two, second-generation, battery-electric drive trains both powered by Panasonic 18650 Li Ion cells. AMP’s E-100 V.2 all electric drive train features a 100 kWh battery pack offering a range of up to 100 miles. AMP’s E-GEN, introduced in 2014, is its newest drive train employing a 2200 nm permanent magnet electric drive motor coupled to a small internal combustion engine (ICE) that drives the electric motor in generator mode to keep the battery pack within the desired level of charge.

Market Entry

Based on market experience, we believe that the duty cycle of the average medium-duty local delivery truck market represents the appropriate entry point to launch electric trucks due to the quick financial payback associated with electrification. To our knowledge, our Workhorse E-GEN™ electric truck, which has an EPA approved on-board internal combustion engine, provides a three-year payback without any government financial incentives. Over the typical 10-year life of a medium-duty delivery truck, our Workhorse E-GEN electric truck is designed to save its owner over \$100,000 in fuel and maintenance savings, a projected 75% reduction in costs compared to gas powered vehicles based on current fuel and electricity costs.

TABLE OF CONTENTS

Our Workhorse E-GEN electric truck is the first of its kind. Purpose-built for the package delivery vehicle market, it is expected to offer three-times the miles per gallon than typical gasoline-powered vans in use today. The E-GEN power train is unique in that it employs a 2200 nm permanent magnet motor/generator for propulsion plus a 2.4 Liter internal combustion engine that turns the electric motor in generator mode to recharge the battery pack under certain conditions i.e. the battery pack falls below a predetermined level, the vehicle is in park with the key out, and the emergency brake is on. As such, it can be charging while the driver stops the vehicle to make a delivery or pauses for lunch.

We believe the E-GEN will change the economics of EV acquisition by reducing battery costs, which in the past has been an impediment to the mass adoption of commercial EVs. By integrating Panasonic 18650 batteries with our proprietary battery management system, control software, charging innovations, and mechanical packaging, we are able to keep total vehicle cost at an attractive price point. At the same time, AMP is continually assessing battery technology and applications.

HorseFly™

Our unique HorseFly line of drones is designed to be the ‘last mile’ solution in delivery logistics. We worked with the University of Cincinnati to develop the HorseFly to meet the rigors of package delivery and to have eight rotors and redundant systems to ensure safety in the air. Today, we estimate that it costs approximately \$1 to move a 20,000-pound diesel-powered truck one mile. While we believe our Workhorse trucks can reduce the standard delivery costs from \$1 to less than \$0.30 cents per mile based on current costs of fuel, We expect that having drones handle the last leg of delivery could further potentially reduce the cost to about \$.03 cents for the last mile. The all weather HorseFly battery-powered drone will carry up to 10 pounds of cargo with a 15-mile range. It is designed to meet the anticipated FAA drone guidelines expected in 2015, of which there is no guarantee, and is differentiated from other drones as it is designed to work in tandem with a Workhorse electric truck. HorseFly will deliver packages, loaded on-route by the truck's driver, to remote locations while the driver continues on the main delivery route. HorseFly will then rejoin the truck at its new location after its delivery is completed, saving the fleet operator much of the time and fuel cost of the last, most expensive, mile. Also while the HorseFly is atop the Workhorse truck, it can quickly charge its batteries from the truck's large battery pack. We believe this implementation is superior to the proposed deployment of other delivery drones wherein the package is loaded at a distant warehouse and the drone must make a round trip flight to the delivery address and back to the warehouse. Other applications for the HorseFly include transmission line inspections and agricultural surveys.

Facilities

In March of 2013, we purchased the former Workhorse Custom Chassis assembly plant in Union City, Indiana from a subsidiary of Navistar International with the goal of transforming the company into the leading producer of electric medium duty trucks in the United States. To our knowledge, Workhorse Advanced Vehicles is the only commercial electric vehicle OEM in the country.

With the purchase we acquired a 220,000 sq. ft. factory, a 50,000 sq. ft. engineering facility, all the intellectual property and patents, and access to the 440 Workhorse dealers across the U.S., and established a supply agreement with its parts supplier UpTime parts. The mechanical, electrical and software design and engineering is done at our Cincinnati, Ohio headquarters. Ownership of this plant enables us to build new chassis with gross vehicle weight capacities of between 10,000 and 26,000 pounds and offer them with four different fuel variants—electric, gas, propane (LPG) and compressed natural gas (CNG).

Intellectual Property

We have six issued patents and two pending in the U.S. We also plan to pursue appropriate foreign patent protection. AMP also has five pending trademark applications and two issued trademark registrations in the U.S. with intent to pursue foreign trademark registration as well.

Competitive Landscape

We believe our ability to meet fleet performance specifications and reduce vehicle lifecycle costs affords us significant advantages over competing EVs. Other companies currently competing in the EV fleet logistics market include Ford Motor Company, Freightliner, Smith Electric Vehicles, and Electric Vehicles International. Batteries are the most expensive part of an EV. Workhorse uses Panasonic LI batteries; therefore our E-GEN battery packs are under \$20,000 since they can be recharged from the ICE, as compared to the industry's average battery pack cost of \$72,000. Competing EV trucks have limited range because they are electric only. Our EPA-approved E-GEN emergency range electric, medium-duty truck offers greater range since the truck can recharge when parked. As an OEM, our manufacturing costs are lower as compared to competitors that are installing their drive trains into chassis from another manufacturer.

Management Team

Our executive team has deep experience in the automotive industry, engineering field, and public company management. Our Chairman has 34 years of automotive and engineering management experience and was CEO of Hummer and General Manager of Cadillac. Our Founder and CEO is a veteran entrepreneur who has founded several successful start-ups, while our CFO has 35 years of financial management experience at several public companies. Our engineering executives are from Navistar, Autocar LLC, Procter and Gamble, and the United States Naval Research Lab.

Our Products

Powertrain :

E-GEN

In January 2014, we submitted a provisional patent application for a new drive system. This revolutionary design is an extended range electric drive system that we call the E-GEN Drive. This system is an electric drive that has a gasoline/propane or CNG engine that functions as an auxiliary generator that only runs when the battery reaches a certain level of depletion, the vehicle is in PARK, the key is out and the emergency break is on. This system combines battery-electric propulsion with a low-horsepower, fossil fuel engine that powers the electric motor in generator mode to produce a vehicle that gets two to four times the miles per gallon of its conventional counterpart, thus providing the fleet operator with a solution that has a three-year payback without any government incentives. We believe that this is the ideal solution for the domestic package delivery fleet operators as well as other specialized markets (i.e. shuttle, school, public transportation buses, and specialty-use vehicles). The Environmental Protection Agency (EPA) considers it an electric vehicle and has approved it for on-road use. Trucks equipped with E-GEN Drive qualify for \$32,800 incentives from the Drive Clean Chicago program

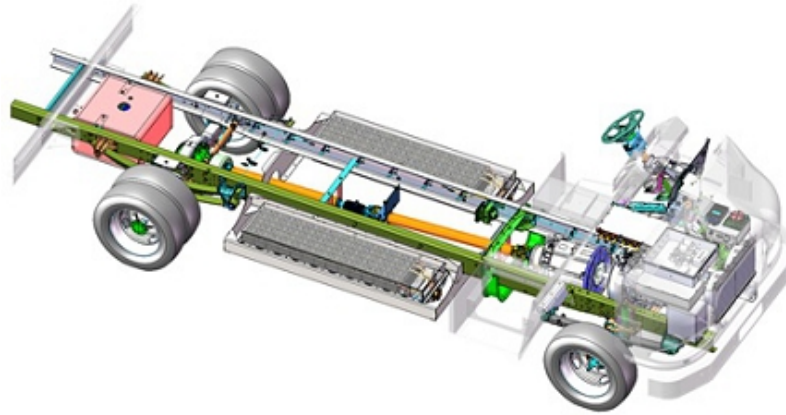

Our approach to the commercial market is to provide alternative-fueled chassis at competitive prices that are as reliable and consistent, in all aspects, as the Navistar chassis that last rolled off the line in the last quarter of 2012. Our sales strategy targets the top fleet buyers. We have forged an arrangement for logistics support with UpTime Parts, Inc. and structured an engine supply agreement with Power Solutions International.

We are focused on the extended range electric E-GEN solution since it offers the customer a solution that provides answers to their key concerns with electric vehicles (i.e. range issues in cold weather, peak season requirements, infrastructure costs, and “what are my options if there is a power outage?”).

E-100

Our AMP E-100 all-electric, medium-duty truck employs our second-generation full electric power-train that is a significant improvement to our first generation. It includes a single electric motor with no transmission and new lighter, high-density Lithium Ion batteries giving it a range of up to 100 miles. This application has received California Air Resources Board approval for sale in California and is now on the California HVIP list and eligible for incentive purchase. Additionally, we are also approved in New York under the NYSERDA Program and approved for both new trucks and repowers under the Drive Clean Chicago incentive program.

Chassis:

W88

The new W88 chassis is designed to meet the needs of a wide range of customers. At the same time, it is a universal chassis from an operations perspective. We believe that this chassis will be the workhorse of our product offerings. We expect to offer this chassis with gross vehicle weight GVW ratings of 10,000 to 26,000 pounds. It will also be offered with drive train and fuel systems ranging from all-electric, extended range electric EREV utilizing gasoline, propane or CNG, PSI gasoline 6-liter engine, propane, and CNG.

W22

The W22 chassis is designed to meet the needs of the recreational vehicle market for weight ratings up to 26,000 GVW. It has been in the marketplace for over ten years and is well-proven for this application. If we elect to pursue the RV market, we will offer this chassis with an engine that is competitive and at the same time has market acceptance and appeal in the RV sector. We believe the PSI 8.8 Liter multi-fuel engine has market appeal for the RV market.

Applications for these Products:

Commercial Step Vans

Package Delivery Industry: Approximately 80% of the vehicles in this segment operate on a fixed route and travel fewer than 100 miles per day, stop more than 100 times within an average duty cycle of eight to ten hours, and return to an indoor distribution center. The best examples include: UPS, FEDEX, FEDEX Ground, DHL and Purolator.

Product Delivery Industry: Approximately 70% of the vehicles in this segment operate on a fixed route and travel fewer than 100 miles per day, stop between 50 and 100 times within an average duty cycle of eight to ten hours, and return to a distribution center that is either indoors, or the vehicles are stored at the dock, or in an outdoor lot adjacent to the distribution facility. Examples are: Frito-Lay, Pepsi, Coke, Aramark, Bimbo Bakeries, Peapod and other grocery delivery services.

Laundry and Uniform Service Industry: Approximately 60% of the vehicles in this segment operate on a fixed route and travel approximately 100 miles per day, stop between 30 and 50 times within an average duty cycle of eight to ten hours, and return to a laundry facility where the vehicles are stored outside the facility. Cintas, Aramark, UniFirst and Diaper Service are examples.

Food Service Industry: Approximately 80% of the vehicles in this segment operate on a fixed route and travel approximately 100 miles per day stopping between 10 and 30 times within an average duty cycle of eight to ten hours. They return to a commissary facility where the vehicles are stored outside the facility and serviced at this common facility. Food trucks fall into this category.

Utility Industry: The route that these vehicles follow is dependent on the utility and the energy company's territory. Some utilities, for example, are captive to a county or surrounding counties of one large metro area. This model is ideal for a segment of the fleet to be all electric utility vehicles. For the utilities that cover the entire state or even multiple states, CNG, or Hybrid CNG/Electric vehicles are required.

Special Use Industry: This segment basically consists of what is not already mentioned including. SWAT, Warehouse on Wheels i.e. Snap-on-Tools, HVAC, Plumbers, and other service applications that require a large cube storage vehicle fit into this category.

The current number of commercial step vans in use in the US is approximately 320,000 units. Today between 3% and 4% are replaced with new vehicles every year. A number of the larger fleets that effectively utilize this type of vehicle replace vehicles at a rate closer to 7% per year. We believe that with the proper mix of alternative fuel options combined with purpose-built chassis for specific use in this segment will result in a replacement rate of as much as 10% in the initial transition period and then a 5% to 7% overall rate long term.

Medium Duty Buses

We believe we could potentially access through the sale of the medium duty bus (108"H x 95.5 W x 247"to 286" L). Para-Transit, Shuttle and School Buses are part of this segment. We are able to offer alternative fuel solutions, as well as innovative E-GEN EREV solutions combined with the AMP/Workhorse chassis.

Special Use Vehicles

The special use vehicle segment includes emergency vehicles, wreckers, construction equipment, communications equipment and military base application. This segment is similar to Medium-duty buses in terms of volume potential.

TABLE OF CONTENTS

Recreational Vehicles (RV)

The final segment that we believe will have significant volume potential for us is the Class 5 and 6 RV chassis market. We believe that the right combination of drive system and Workhorse chassis has the potential to capture a significant portion of the market. Currently, RV manufacturers only have one option if they want to purchase a class 5 or 6 gasoline chassis for an RV application.

Technology

Batteries Are Key

The battery pack is key to the design, development, and manufacture of advanced electric-vehicle power trains. Where some other EV manufacturers purchase their batteries in a plug-and-play pack, we build our own battery packs. This keeps the intellectual property related to the design and production of the pack in-house and avoids the issues that occur when a battery supplier fails. And it also enables us to pay less for our batteries and pack than do our competitors thus our all-electric truck is less expensive than competitive vehicles. We use the Panasonic or LG Chem 18650 cells and design the pack around these commodity cells.

In-House Software Development is Essential

Our power trains encompass the complete motor assemblies, computers, and software required for vehicle electrification. We use off-the-shelf, proven components and combine them with our proprietary software.

Innovation is the Future

We have developed a cloud-based, remote management system to manage and track the performance of all of the vehicles that we deploy in order to provide a 21st Century solution for fleet managers.

We are in the process of developing an Unmanned Aerial Vehicle (UAV) system named HorseFly™ to work in concert with the Workhorse EGen and E100 electric powered truck products. Our unique HorseFly line of drones is designed to be the ‘last mile’ solution in delivery logistics. We worked with the University of Cincinnati to develop the HorseFly to meet the rigors of package delivery and to have eight rotors and redundant systems to ensure safety in the air. Today, we estimate that it costs approximately \$1 to move a 20,000-pound diesel-powered truck one mile. While we believe our Workhorse trucks can reduce the standard delivery costs from \$1 to less than \$0.30 cents per mile based on current costs of fuel, We expect that having drones handle the last leg of delivery could further potentially reduce the cost to about \$.03 cents for the last mile. The all weather HorseFly battery-powered drone will carry up to 10 pounds of cargo with a 15-mile range. It is designed to meet the anticipated FAA drone guidelines expected in 2015, of which there is no guarantee, and is differentiated from other drones as it is designed to work in tandem with a Workhorse electric truck. HorseFly will deliver packages, loaded on-route by the truck's driver, to remote locations while the driver continues on the main delivery route. HorseFly will then rejoin the truck at its new location after its delivery is completed, saving the fleet operator much of the time and fuel cost of the last, most expensive, mile. Also while the HorseFly is atop the Workhorse truck, it can quickly charge its batteries from the truck's large battery pack. We believe this implementation is superior to the proposed deployment of other delivery drones wherein the package is loaded at a distant warehouse and the drone must make a round trip flight to the delivery address and back to the warehouse. Other applications for the HorseFly include transmission line inspections and agricultural surveys.

Locations and Facilities

The following table sets forth the location, approximate size and primary use of our principal owned, leased and licensed facilities:

Location	Approximate Size (Building) in Square Feet	Primary Use	Owned, Leased or Licensed	Lease/ License Expiration Date (if applicable)
Loveland, Ohio	30,000	Administration, research and development and manufacturing	Leased	September 2018
Union City, Indiana	270,000	Manufacturing	N/A	N/A

[TABLE OF CONTENTS](#)

Our company headquarters and R & D facility is located at 100 Commerce Drive, Loveland, Ohio, a Cincinnati suburb. We occupy a 30,000 sq. ft. facility that allows for the manufacture of a limited number of drive trains and chassis per year. Until full production is begun in Union City, Drive trains will be delivered to the Workhorse facility in Indiana or shipped to our dealer network for onsite installation in conversion vehicles.



Workhorse/AMP Trucks, Inc. Location

Our truck assembly facility is located in Union City, Indiana. This facility consists of three buildings with 270,000 square feet of manufacturing and office space on 46 acres.

Workhorse Facility

In March of 2013, we purchased the former Workhorse Custom Chassis assembly plant in Union City, Indiana. With this acquisition, we became an Original Equipment Manufacturer (OEM) of Class 3-6 commercial-grade, medium-duty truck chassis to be marketed under the well-respected Workhorse® brand.

Ownership and operation of this plant enables us to build new chassis with gross vehicle weight capacity of between 10,000 and 26,000 pounds and offer them in four different fuel variants—electric, gas, propane, and CNG. We plan to offer well-known Workhorse chassis like the W22 and the new, 88” track W88 truck chassis that will be offered to fleet purchasing managers at price points that we believe are both attractive and cost competitive.



At the same time, AMP intends to partner with engine suppliers and body fabricators to offer fleet-specific, custom, purpose-built chassis that provide total cost of ownership solutions that are superior to the competition.

In addition to building our own chassis, we design and produce battery-electric drive trains that can be installed in new Workhorse chassis or installed as repower packages to convert used Class 3-6 medium-duty vehicles to electric power from diesel or gasoline power to electric power. Our approach is to provide battery-electric power trains utilizes proven, automotive-grade, mass-produced parts in its architecture coupled with in-house control software that it has developed over the last five years.

TABLE OF CONTENTS

The Workhorse Custom Chassis acquisition includes other important assets including the Workhorse brand and logo, intellectual property, schematics, logistical support from UpTime Parts (a Navistar subsidiary) and, perhaps most importantly, a network of 400 plus sales and service outlets across North America. We believe the combination of AMP's chassis assembly capability, coupled with its ability to offer an array of fuel choices, gives AMP/Workhorse a unique opportunity in the marketplace.

Manufacturing

Vehicle assembly

We currently assemble our vehicles at the combination of our research and development facility located in Loveland, Ohio and our inspection facility located in Union City, IN. These combined facilities have the capacity to produce 250 vehicles per year. We intend to start utilizing our production facility in Union City, IN starting in late 2015. The facility has capacity to produce 60,000 units per year. This maximum capacity is based on running two (10) hour shifts four days per week. We believe we have access to a skilled production workforce that is available and ready to restart the facility in a short period of time. The production facility is capable of being run at an annual production rate of 500 units with a breakeven rate of 2,000 units per year.

Supply chain

Our production operations depend on obtaining systems, components, raw materials, parts, manufacturing equipment and other supplies and services from reliable suppliers in adequate quality and quantity in a timely manner. Our current supply chain is primarily located in North America, with approximately 90% of our suppliers located in North America, 5% located in Europe and 5% located in the Asia.

We have secured supply agreements for our critical components including our batteries. However, these are dependent on volume to ensure that they are available at a competitive price. We obtain components and raw materials from multiple sources whenever possible, similar to other vehicle manufacturers, however, certain of our primary vehicle systems and the components and raw materials used in our vehicles are purchased by us from a single source.

We also are subject to fluctuations in the prices of the components and raw materials we use in our business as a result of our practice of purchasing systems, components and raw materials through purchase orders. Prices for the systems, components and raw materials we use in our business fluctuate depending on market conditions and global demand. We believe that we have adequate supplies or sources of availability of the systems, components and raw materials necessary to meet our production and supply requirements.

Quality control

Our quality control efforts are divided between product quality and supplier quality, both of which are focused on designing and producing products and processes with high levels of reliability. We have a dedicated quality control employees that work with our engineering team and our suppliers to ensure that the product designs meet functional specifications and durability requirements. Our quality control employees also work with our suppliers to ensure that their processes and systems are capable of delivering the parts and components we need at the required quality level, on time, and on budget. We utilize a Post Delivery Inspection system and historically the facility in Union City has operated with an ISO 9001 certification.

Warranty policies

We sell our vehicles with standard component-based warranties under which each vehicle component is covered for a specific period of time. The chassis, generator motor, and related components are warranted for three years or 36,000 miles while the electrification package is covered for three years or 60,000 miles. Finally, the battery pack is covered for eight years or 100,000 miles, whichever comes first, subject to certain exclusions and exceptions.

Marketing

Our sales team is focused on a targeted list of high profile, former purchasers, and current buyers of the Workhorse chassis with the goal of securing purchase orders from these companies. Our priority is to establish the commercial step van as our core business. Our goal is to be the best choice for a vehicle in this segment regardless of the fuel type that the customer chooses. Additionally, our sales plan is to meet with the top potential customers and obtain purchase orders for new electric, extended range electric, gasoline, propane, or CNG vehicles for their production vehicle requirements.

The second segment that we are focused on is medium-duty buses. This is based on fact that we completed two 15-passenger para-transit buses for BARTA (Berks County Regional Transit Authority) in Pennsylvania. These buses are equipped with wireless charging and represent a unique solution for a number of applications (i.e. airport hotels, rental car companies and municipal transit authorities). Once we have completed all of the relevant testing on these buses we will work with bus body builders to develop pricing and plan to offer a Workhorse/AMP chassis for sales in late 2016.

TABLE OF CONTENTS

Finally, since our competitive advantage in the marketplace is our ability to provide purpose-built solutions to customers that have unique requirements at relatively low-volume, we have submitted multiple proposals to companies for purpose-built vehicle applications.

AMP Trucks will promote the Workhorse brand at select trade shows, conferences and briefings.

Strategic Relationships

Power Solutions International: PSI supplies engines that are certified and calibrated for on-road use by companies such as AMP/Workhorse utilizing gasoline, propane or CNG as a fuel. They have the ability and the resources to provide engines that meet fleet requirements in volumes that are significantly below the volume requirements of companies like Ford or Freightliner for similar specialized powertrain systems.

Morgan Olsen, Utilimaster, TransTech Bus, ECO, and other up-fitters or body fabricators : All of these companies build bodies customized for the needs of their customers and mated to chassis that are available to them from the short list of chassis suppliers. The functionality and configuration the end-user receives in the finished product is limited by the available chassis/powertrain. AMP/Workhorse will work with these organizations to provide chassis that not only best fit the needs of the end user customer but also provide the customer with a competitive advantage in their specific industry or application.

Research and Development

The majority of our research and development is conducted in-house at our facilities near Cincinnati, Ohio. Additionally, we contract with engineering firms as well as the University of Cincinnati to assist with validation and certification requirements as well as specific vehicle integration tasks.

Competitive Companies

The medium-duty commercial vehicle market is highly competitive and we expect it to become even more so in the future as additional companies launch competing vehicle offerings. The medium-duty commercial alternatively fueled vehicle market, however, is less developed and competitive. There are two primary competitors in the medium-duty vehicle segment in the US market: Ford and Freightliner. Neither has disclosed any plans to offer 100% EV or EREV vehicles in this segment. Ford is vertically integrated building a complete vehicle or chassis including Ford engine and transmission. They provide a chassis as a strip-chassis (which is similar to the Workhorse product) or they provide it with a cab. Freightliner provides a chassis as a strip-chassis, which is similar to the Workhorse/AMP Truck chassis.

We believe the most dramatic difference between AMP and the other competitors in the medium duty truck market is our ability to offer customers purpose-built solutions that meet the needs of their unique requirements at a competitive price. While there are many electric car companies from abroad, there are only a few foreign companies that have vehicles in the category of medium-duty trucks.

We believe that the primary competitive factors within the medium-duty commercial vehicle market are:

- the difference in the initial purchase prices of electric vehicles and comparable vehicles powered by internal combustion engines, both including and excluding the impact of government and other subsidies and incentives designed to promote the purchase of electric vehicles;
- the total cost of vehicle ownership over the vehicle's expected life, which includes the initial purchase price and ongoing operational and maintenance costs;
- vehicle quality, performance and safety;
- government regulations and economic incentives promoting fuel efficiency and alternate forms of energy;
- the quality and availability of service for the vehicle, including the availability of replacement parts; and
- for electric vehicles, the range over which they may be driven on a single battery charge.

GOVERNMENT REGULATION

Our electric vehicles are designed to comply with a significant number of governmental regulations and industry standards, some of which are evolving as new technologies are deployed. Government regulations regarding the manufacture, sale and implementation of products and systems similar to our electric vehicles are subject to future change. We cannot predict what impact, if any, such changes may have upon our business. We believe that our vehicles are in conformity with all applicable laws in all relevant jurisdictions.

Emission and fuel economy standards

Government regulation related to climate change is under consideration at the U.S. federal and state levels. The EPA and the National Highway Traffic Safety Administration, or NHTSA, issued a final rule for greenhouse gas emissions and fuel economy requirements for trucks and heavy-duty engines on August 9, 2011, which will have an initial phase in starting with model year 2014 and a final phase in occurring in model year 2017. NHTSA standards for model year 2014 and 2015 will be voluntary, while mandatory standards will first come into effect in 2016.

The rule provides emission standards for CO₂ and fuel consumption standards for three main categories of vehicles: (i) combination tractors, (ii) heavy-duty pickup trucks and vans and (iii) vocational vehicles. We believe that the Workhorse chassis would be considered "vocational vehicles" under the rule. According to the EPA and NHTSA, vocational vehicles consist of a wide variety of truck and bus types, including delivery, refuse, utility, dump, cement, transit bus, shuttle bus, school bus, emergency vehicles, motor homes and tow trucks, and are characterized by a complex build process, with an incomplete chassis often built with an engine and transmission purchased from other manufacturers, then sold to a body manufacturer.

The EPA and NHTSA rule also establishes multiple flexibility and incentive programs for manufacturers of alternatively fueled vehicles, such as the Workhorse E-100 full electric and the E-Gen Electric, including an engine averaging, banking and trading, or ABT, program, a vehicle ABT program and additional credit programs for early adoption of standards or deployment of advanced or innovative technologies. The ABT programs will allow for emission and/or fuel consumption credits to be averaged, banked or traded within defined groupings of the regulatory subcategories. The additional credit programs will allow manufacturers of engines and vehicles to be eligible to generate credits if they demonstrate improvements in excess of the standards established in the rule prior to the model year the standards become effective or if they introduce advanced or innovative technology engines or vehicles.

The Clean Air Act requires that we obtain a Certificate of Conformity issued by the EPA and a California Executive Order issued by CARB with respect to emissions for our vehicles. The Certificate of Conformity is required for vehicles sold in states covered by the Clean Air Act's standards and the Executive Order is required for vehicles sold in states that have sought and received a waiver from the EPA to utilize California standards. The California standards for emissions control for certain regulated pollutants for new vehicles and engines sold in California are set by CARB. States that have adopted the California standards as approved by EPA also recognize the Executive Order for sales of vehicles.

Manufacturers who sell vehicles in states covered by federal requirements under the Clean Air Act without a Certificate of Conformity may be subject to penalties of up to \$37,500 per violation and be required to recall and remedy any vehicles sold with emissions in excess of Clean Air Act standards. In 2013, we received approval from CARB to sell the E-100 in California based on our own emissions tests.

Vehicle safety and testing

The National Traffic and Motor Vehicle Safety Act of 1966, or the Safety Act, regulates motor vehicles and motor vehicle equipment in the United States in two primary ways. First, the Safety Act prohibits the sale in the United States of any new vehicle or equipment that does not conform to applicable motor vehicle safety standards established by NHTSA. Meeting or exceeding many safety standards is costly, in part because the standards tend to conflict with the need to reduce vehicle weight in order to meet emissions and fuel economy standards. Second, the Safety Act requires that defects related to motor vehicle safety be remedied through safety recall campaigns. A manufacturer is obligated to recall vehicles if it determines that the vehicles do not comply with a safety standard. Should we or NHTSA determine that either a safety defect or noncompliance exists with respect to any of our vehicles, the cost of such recall campaigns could be substantial.

Battery safety and testing

Our battery packs conform to mandatory regulations that govern transport of "dangerous goods," which includes lithium-ion batteries, that may present a risk in transportation. The governing regulations, which are issued by PHMSA, are based on the UN Recommendations on the Safe Transport of Dangerous Goods Model Regulations, and related UN Manual of Tests and Criteria. The requirements for shipments of these goods vary by mode of transportation, such as ocean vessel, rail, truck and air.

Our battery module suppliers have completed the applicable transportation tests for our prototype and production battery packs demonstrating our compliance with the UN Manual of Tests and Criteria, including:

- altitude simulation, which involves simulating air transport;
- thermal cycling, which involves assessing cell and battery seal integrity;
- vibration, which involves simulating vibration during transport;
- shock, which involves simulating possible impacts during transport;

TABLE OF CONTENTS

- external short circuit, which involves simulating an external short circuit; and
- overcharge, which involves evaluating the ability of a rechargeable battery to withstand overcharging.

Vehicle dealer and distribution regulation

Certain states' laws require motor vehicle manufacturers and dealers to be licensed in such states in order to conduct manufacturing and sales activities. To date, we are registered as both a motor vehicle manufacturer and dealer in Indiana and Ohio as well as a dealer in California and Chicago. We have not yet sought formal clarification of our ability to manufacture or sell our vehicles in any other states.

Intellectual Property

We has five pending trademark applications and two issued trademark registrations in the U.S. with intent to pursue foreign trademark registration as well. We have one pending U.S. patent application, six existing patents and also plan to pursue appropriate foreign patent protection on those inventions. The following is a summary of our patents:

Country	Status	Serial Number	Application Date	Patent Number	Issue/Grant Date	Title	Expiration Date
Canada	Granted	2523653	10/17/2005	2523653	12/22/2009	VEHICLE CHASSIS ASSEMBLY	10/17/2025
United States	Granted	11/252,220	10/17/2005	7,717,464	05/18/2010	Vehicle Chassis Assembly	09/06/2026
United States	Granted	11/252,219	10/17/2005	7,559,578	07/14/2009	Vehicle Chassis Assembly	09/06/2026
United States	Granted	29/243,074	11/18/2005	D561,078	02/05/2008	Vehicle Header	02/05/2022
United States	Granted	29/243,129	11/18/2005	D561,079	02/05/2008	Vehicle Header	02/05/2022
United States	Granted	13/283,663	10/28/2011	8,541,915	09/24/2013	DRIVE MODULE AND MANIFOLD FOR ELECTRIC MOTOR DRIVE ASSEMBLY	12/16/2031
United States	Filed	61/933,350	01/30/2014	NA	NA	ONBOARD GENERATOR DRIVE SYSTEM FOR ELECTRIC VEHICLES THAT SHARE AN ELECTRIC MOTOR FOR BOTH PROPULSION AND GENERATION	01/30/2015

Agreements

Momentum Dynamics and BARTA (Berks County Regional Transportation Authority)

On December 29, 2012, the Company entered into an Agreement with Momentum Dynamics to engineer, develop, and produce two development vehicles for BARTA in Reading, Pennsylvania. We are seeking to have this project generate the following: promote the use of AMP products for other similar applications i.e. rental car shuttle buses, motel and hotel shuttle buses, school buses, and other hospitality shuttle bus applications, network the AMP products through the Momentum Dynamic sales channel, and promote the sale of AMP products to the Departments of Transportation throughout the US.

Navistar International Truck

In April of 2012 we signed a development agreement with Navistar International Truck. The scope of work for this project was to repower two 2004 vintage W1652 vehicles, which were originally produced by Navistar. Their customer, a large package delivery company, has an interest in repowering these vehicles with something other than the current diesel engine that is in this vehicle. Navistar was interested in working with them to repower these vehicles with either electric or some other fuel system. With electric being the most desirable if the customer's price point could be met, AMP was subcontracted by Navistar to perform the electric repower, and in August of 2012 AMP delivered the first vehicle to Navistar. The vehicle passed their initial performance requirements which were based on their end customer's specifications. In October 2012 Navistar turned the project over to AMP to work directly with them to provide a 100% electric repowered vehicle.

[TABLE OF CONTENTS](#)

AMP has entered into a purchase agreement with this customer to supply 18 all-electric Workhorse E-100 Walk In Vans to be deployed in the Houston-Galveston, Texas area. The U.S. Department of Energy (DOE) selected this project to improve local air quality in the Houston-Galveston area, which is currently designated as a National Ambient Air Quality Non-Attainment Area. The major transportation company has also entered into a purchase agreement to purchase two E-GEN 100 vehicles to be delivering in the first quarter of 2015.

Employees

We currently have 13 full-time and two part-time employees located in Loveland, Ohio and two full-time and one part-time employees located in Union City, Indiana. We also contract for hire with approximately 17 outside consultants and contractors. Three of our employees are engaged in administrative aspects of our business and 15 are involved in research and development. Ten of our contractors are involved in research and development and seven are involved in administration.

Legal Proceedings

We are not currently a party to any pending or threatened legal proceeding or government investigations.

MANAGEMENT

Executive Officers and Directors

Set forth below is a list of the names, ages as of November 20, 2014 and positions, and a brief account of the business experience of the individuals who serve as our executive officers and directors as of the date of this prospectus.

Name	Age	Position
James E. Taylor	58	Chairman of the Board of Directors
Stephen S. Burns	55	Director, Chief Executive Officer, Secretary and Treasurer
Martin J. Rucidlo	55	President
Julio C. Rodriguez	56	Chief Financial Officer
Raymond J. Chess	57	Director

Our officers and directors are elected annually for a one year term or until their respective successors are duly elected and qualified or until their earlier resignation or removal.

The following is a brief summary of the background of each of our directors and executive officers, including specific information about each director's experience, qualifications, attributes or skills that led the Board of Directors to the conclusion that the individual is qualified to serve on our Board of Directors.

James E. Taylor, Chairman of the Board of Directors

Mr. Taylor has three decades of automotive experience in three countries. His last GM assignment, he served as CEO of Hummer from August 2008 to February 2010 during the attempted divestiture. Prior to that, he was President of Cadillac from 2005 to 2008, responsible for the product planning, marketing, promotional and sales activities that significantly contributed to Cadillac's global renaissance. Prior to that, Mr. Taylor was a vehicle line executive for Cadillac from 1995 to 2005, directing the planning, engineering and manufacturing of the award-winning ground up Cadillac CTS, SRX and the STS models, which contributed significantly to the resurgence of Cadillac. Mr. Taylor holds a Bachelors of Science degree in Mechanical Engineering & Management from McMaster University, Ontario, Canada. Mr. Taylor currently serves as EVP for Manufacturing and Purchasing for Fisker Automotive and Technologies, LLC. We believe Mr. Taylor's training as an engineer, his knowledge and experience with respect to the automobile industry qualifies him to serve on our Board of Directors.

Stephen S. Burns, Director, Chief Executive Officer, Treasurer and Secretary

Mr. Burns, a Co-Founder of our company, has served as our CEO since inception. Mr. Burns was appointed as CEO, CFO, Treasurer and Secretary of the Company on December 28, 2009. Mr. Burns had founded several companies, most recently iTookThisOnMyPhone.com, a mobile photo and video-sharing technology company, MobileVoiceControl, Inc. a developer of high-end speech recognition software for smartphones sold to Nuance Communications (NASDAQ:NUAN), Inc. In 2006, AskMeNow [OTC:AKMN] a mobile search and information delivery system sold to Ocean West Holdings in 2005, PocketScript, the leading mobile electronic prescription system in the world which was sold to ZixCorp [NASDAQ:ZIXI] in 2002, Over The Line/AdLink, sold to Gannett Co. Inc. (NYSE:GCI) in 1994 and the design and development of Suspension Parameter Measurement Machines. We believe Mr. Burns' entrepreneurial background as well as his management and leadership pedigree qualify him to serve on the Board of Directors.

Martin J. Rucidlo, President

Mr. Rucidlo has served as our President since August 2012 and as the Director of Sales for AMP Electric Vehicles Inc. from 2010. Mr. Rucidlo has over 30 years of experience in a variety of industries ranging from VP Sales & Marketing to General Manager positions in the aerospace, packaging, software, medical technology, and automotive industries. He has held executive-level positions at Zix Corporation, Quest Diagnostics Inc., Nuance Communications, PCC Airfoils and Alcoa. Prior to joining AMP, Mr. Rucidlo served as the Director of Technology Sales at Quest Diagnostics from March 2009 to May 2010, Director of NVC Healthcare Sales at Nuance Communications from August 2006 to March 2009, VP Sales Care Delivery Solutions Zix Corporation from February 2001 to January 2005 and VP Sales and Marketing of WS Packaging from November 1996 to February 2001. He holds a Bachelors of Science Degree in Industrial Engineering from The Pennsylvania State University.

Julio C. Rodriguez, Chief Financial Officer

Mr. Rodriguez has served as our President since August 2013. Mr. Rodriguez is a finance executive with over 30 years of experience in financial and operational leadership roles within various industries including the automotive industry. From 1999 until 2013, Mr. Rodriguez served in various executive roles for Genuine Parts Company ("GPC") and its subsidiaries. Most recently, from 2008 through 2013, Mr. Rodriguez served as Director Process Improvement for GPC, whereby Mr. Rodriguez organized, coordinated, executed control process improvement and cost savings projects for all company divisions. Prior to this, from 2006 through 2008, Mr. Rodriguez served as Vice President Finance & Corporate Secretary for Johnson Industries, a subsidiary of GPC. Mr. Rodriguez holds a Bachelor of Science degree in Business Administration and a Bachelor of Science degree in Accounting from Catholic University Caracas, Venezuela.

Raymond J. Chess, Director

Mr. Chess was appointed as a director of our company in October 2013. Mr. Chess served as a Global Vehicle Line Executive for General Motors Co. ("GM"), where he was responsible for global, cross functional general management of the GM crossover market segment from May 2009 through December 2012. Prior to this, from August 2001 until April 2009, Mr. Chess was responsible for GM's commercial truck segment. Previous GM assignments included leadership roles in the full size truck segment, metal fabrication and body assembly. Mr. Chess's background includes broad, hands-on manufacturing leadership roles with manufacturing, engineering and manufacturing floor operations. Mr. Chess holds a Bachelors of Science degree in Mechanical Engineering from Kettering University and an MBA from Indiana University. We believe Mr. Chess's training as an engineer and his knowledge and experience with respect to the automobile industry qualifies him to serve on our Board of Directors.

Other Involvement in Certain Legal Proceedings

None of our directors or executive officers has been involved in any bankruptcy or criminal proceedings, nor have there been any judgments or injunctions brought against any of our directors or executive officers during the last ten years that we consider material to the evaluation of the ability and integrity of any director or executive officer.

Board of Directors Composition and Election of Directors

Our Board of Directors currently consists of three directors.

Our board of directors will consist of _____ members upon the closing of this offering.

All directors hold office until their successors have been elected and qualified or until their earlier death, resignation or removal. At each annual meeting of stockholders, the successors to directors whose terms will then expire will serve from the time of election and qualification until the annual meeting following election and until their successors are duly elected and qualified. A resolution of the board of directors may change the authorized number of directors, and the affirmative vote of our board of directors may amend the provision of our bylaws establishing the number of directors.

Director Independence

Under the listing requirements and rules of the NASDAQ Capital Market, independent directors must comprise a majority of our board of directors as a listed company within one year of the closing of this offering.

Board Committees

Prior to the effectiveness of this offering, our board of directors will establish an audit committee, a compensation committee, and a nominating and corporate governance committee, each of which will operate, upon the completion of this offering, under a charter that has been approved by our board of directors. The composition of each committee will be effective upon the completion of this offering. Each committee will have a written charter prior to the effectiveness of this offering.

Prior to the effectiveness of this offering, our board of directors will make a determination of the independence of the members of the audit committee, the compensation committee and the nominating and corporate governance committee under The NASDAQ Marketplace Rules, as applicable, including, in the case of all of the members of our audit committee, the independence requirements contemplated by Rule 10A-3 under the Securities Exchange Act of 1934. In making such determination, the board of directors will consider the relationships that each director has with our company and all other facts and circumstances that the board of directors deemed relevant in determining director independence, including the beneficial ownership of our capital stock by each director.

TABLE OF CONTENTS

Audit Committee. Upon the completion of this offering, our audit committee will be comprised of Mr. _____ and Mr. _____. Our board of directors has determined that _____ is an audit committee financial expert, as defined by the rules of the Securities and Exchange Commission, and satisfies the financial sophistication requirements of applicable NASDAQ rules.

Our audit committee will be authorized to:

- approve and retain the independent auditors to conduct the annual audit of our financial statements;
- review the proposed scope and results of the audit;
- review and pre-approve audit and non-audit fees and services;
- review accounting and financial controls with the independent auditors and our financial and accounting staff;
- review and approve transactions between us and our directors, officers and affiliates;
- recognize and prevent prohibited non-audit services;
- establish procedures for complaints received by us regarding accounting matters;
- oversee internal audit functions, if any; and
- prepare the report of the audit committee that the rules of the Securities and Exchange Commission require to be included in our annual meeting proxy statement.

Compensation Committee. Upon completion of this offering, our compensation committee will be comprised of _____, and _____. None of the members of our compensation committee at any time has been one of our officers or employees.

Our compensation committee will be authorized to:

- review and recommend the compensation arrangements for management, including the compensation for our president and chief executive officer;
- establish and review general compensation policies with the objective to attract and retain superior talent, to reward individual performance and to achieve our financial goals;
- administer our stock incentive plans; and
- prepare the report of the compensation committee that the rules of the Securities and Exchange Commission require to be included in our annual meeting proxy statement,

Nominating and Governance Committee. Upon completion of this offering, our nominating and governance committee will be comprised of _____, and _____.

Our nominating and governance committee will be authorized to:

- identify and nominate members of the board of directors;
- develop and recommend to the board of directors a set of corporate governance principles applicable to our company; and
- oversee the evaluation of our board of directors.

Insider Participation and Other Relationships

Stephen S. Burns, our Chief Executive Officer, is also a member of our board of directors. Stephen S. Burns and _____, two of our directors, are also significant shareholders, each having a beneficial ownership of % and % respectively of our outstanding common stock equivalents immediately before this offering.

There are no family relationships among any of our directors or executive officers.

Code of Business Conduct and Ethics

We have implemented a corporate code of ethics. The Code of Ethics is available on our website at www.ampelectricvehicles.com. We expect that any amendments to the code, or any waivers of its requirements, will be disclosed on our website.

Market for Our Shares of Common Stock

Market Information

Our common stock was quoted on the OTCBB and OTCQB under the symbol "TTSO" from July 14, 2009 through May 24, 2010 and then under the symbol "AMPD" from May 24, 2010 to present. The following table sets forth the range of high and low prices per share of our common stock for each period indicated.

Quarter Ended	March 31		June 30		September 30		December 31	
	High	Low	High	Low	High	Low	High	Low
2012	\$ 0.55	\$ 0.20	\$ 0.29	\$ 0.11	\$ 0.25	\$ 0.10	\$ 0.25	\$ 0.08
2013	0.37	0.12	0.53	0.23	0.51	0.23	0.30	0.10
2014*	0.17	0.10	\$ 0.14	\$ 0.10	\$ 0.14	\$ 0.08	\$ 0.34	\$ 0.12

* The fourth quarter 2014 market information is as of December 10, 2014

Holders of our Common Stock

As of November 20, 2014, there were approximately 94 stockholders of record of our common stock. This number does not include shares held by brokerage clearing houses, depositories or others in unregistered form. The stock transfer agent for our securities is Empire Stock Transfer, Inc., 1859 Whitney Mesa Drive, Henderson, Nevada 89014.

Securities Authorized for Issuance Under Equity Compensation Plans

The following table sets forth the aggregate information of our equity compensation plans in effect as of December 31, 2013:

Plan	Number of securities to be issued upon exercise of outstanding options and rights	Weighted-average price of outstanding options and rights	Number of securities remaining available for future issuance under equity compensation plans (excluding securities reflected in first column)
Equity compensation plans approved by security holders – 2010 Stock Incentive Plan	1,582,000	\$ 0.42	388,250
Equity compensation plans approved by security holders – 2011 Incentive Stock Plan	225,000	\$ 0.70	775,000
Equity compensation plans or arrangements not approved by security holders - 2012 Incentive Stock Plan	21,753,565	\$ 0.77	1,441,500
Equity compensation plans or arrangements not approved by security holders - 2013 Incentive Stock Plan	5,000,000	\$ 0.28	2,500,000
Total	23,560,565	\$ 0.75	5,104,750

EXECUTIVE AND DIRECTOR COMPENSATION

The following summary compensation table sets out details of compensation paid to (a) our principal executive officer; (b) each of our two most highly compensated executive officers who served as executive officers during the fiscal year ended December 31, 2013; and (c) up to two additional individuals for whom disclosure would have been provided under (b) but for the fact that the individual was not serving as our executive officer at the end of the fiscal year ended December 31, 2013, except that no disclosure is provided for any named executive officer, other than our principal executive officer, whose total compensation did not exceed \$100,000 for the fiscal year ended December 31, 2013:

Summary Compensation Table

Name and Principal Position	Year	Salary (\$)	Bonus (\$)	Stock Awards (\$)	Option Awards (\$)	Non-equity Incentive Plan Compensation (\$)	Change in Pension Value and Non-Qualified Deferred Compensation Earnings (\$)	All Other Compensation (\$)	Total (\$)
James E. Taylor Chairman of the Board (1)	2013	-	-	-	-	-	-	80,000	80,000
	2012	125,000	-	-	-	-	-	-	125,000
Stephen S. Burns CEO and Director	2013	200,000	-	-	11,160	-	-	-	211,160
	2012	200,000	-	-	11,160	-	-	-	211,160
Martin J. Rucidlo President	2013	125,000	-	-	30,600	-	-	-	155,600
	2012	108,333	-	-	30,600	-	-	-	138,933
Richard J. Calme Director of Finance	2013	75,000	-	-	3,720	-	-	-	78,720
	2012	75,000	-	-	3,720	-	-	-	78,720
Paul V. Gonzales CFO (2)	2013	-	-	-	-	-	-	-	-
	2012	56,250	-	-	-	-	-	-	56,250
Julio C. Rodriguez CFO	2013	150,000	-	-	45,000	-	-	-	195,000

- (1) Resigned as CEO effective August 10, 2012
- (2) Resigned as CFO effective May 16, 2012

Employment Agreements

James E. Taylor Employment Agreement

On December 8, 2010, we entered into an employment agreement with James E. Taylor pursuant to which he was appointed as the Chief Executive Officer and Vice-Chairman of the Company in consideration of an annual salary of \$300,000. Additionally, Mr. Taylor was eligible for annual bonuses with a target amount of 100% of his salary. As additional compensation, we granted Mr. Taylor options to acquire 1,200,000 shares of common stock at an exercise price of \$0.72 per share for a period of ten years. We also provided Mr. Taylor with a common stock purchase warrant to acquire 600,000 shares of common stock exercisable at any time in the five years following the signing of the agreement at an exercise price of \$2.00 per share. Effective August 10, 2012, Mr. Taylor resigned as the CEO and continues to serve as the Chairman of the Board of Directors. As of December 31, 2013, payroll in the amount of \$87,500 was due and payable and included in accounts payable, based on terms of Mr. Taylor's employment agreement.

Stephen S. Burns Employment Agreement

On December 8, 2010, we entered into an employment agreement with Stephen S. Burns pursuant to which he was appointed as the President of the Company in consideration of an annual salary of \$200,000. Additionally, Mr. Burns will be eligible for annual bonuses with a target amount of 100% of his salary. On December 14, 2014, we agreed to increase Mr. Burns' salary to \$275,000 per annum and agreed to pay a bonus of \$50,000 with \$25,000 payable upon delivering the two Workhorse EGEN and \$25,000 payable upon delivering the 18 Workhorse 100 electric trucks. The actual amount of any bonus may be more or less than such target and will be determined by the Board in its absolute discretion. Half of the bonus may be paid, in the Company's discretion, in unregistered shares of common stock at a price per share equal to the weighted average closing price per share of the common stock over the twenty most recent trading days prior to such grant. In addition to the salary and any bonus, Mr. Burns will be entitled to receive health and fringe benefits that are generally available to the Company's management employees in accordance with the then existing terms and conditions of the Company's

policies. As additional compensation, we granted Mr. Burns options to acquire 300,000 shares of common stock at an exercise price of \$0.72 per share for a period of ten years. We also provided Mr. Burns with a common stock purchase warrant to acquire 300,000 shares of Common Stock exercisable at any time in the five years following the signing of the agreement at an exercise price of \$2.00 per share.

Martin J. Rucidlo Employment Agreement

On August 24, 2012, Martin J. Rucidlo was engaged to serve as the President of our company. On August 24, 2012, Mr. Rucidlo entered into a letter agreement with our company pursuant to which he was appointed as the President of the Company in consideration of an annual salary of \$125,000. As additional compensation, we granted Mr. Rucidlo options to purchase 300,000 shares of the Company's common stock at an exercise price of \$0.21 per share. The options will expire three years from the vesting period with 90,000 options vesting upon the signing of the Agreement and 105,000 options vesting each of the following two years on the anniversary date of the Agreement for a total of 300,000 shares.

[TABLE OF CONTENTS](#)

Julio C. Rodriguez Employment Agreement

On August 15, 2013, we entered into an employment agreement with Julio C. Rodriguez pursuant to which Mr. Rodriguez agreed to serve as the Chief Financial Officer of our company. The Agreement has an effective date of August 7, 2013. Mr. Rodriguez will replace Richard J. Calme who resigned as the Interim Chief Financial Officer. Mr. Calme has been appointed to serve as Director of Finance. Pursuant to the terms of the Employment Agreement, Mr. Rodriguez shall receive an annual salary of \$150,000. In addition to the salary, Mr. Rodriguez will be entitled to receive health and fringe benefits that are generally available to our management employees. As additional compensation, we granted Mr. Rodriguez options to acquire 300,000 shares of common stock at an exercise price of \$0.40 per share for a period of two years.

Outstanding Equity Awards at Fiscal Year-End

The following table sets forth information with respect to the outstanding equity awards of our principal executive officers and principal financial officer during 2012, and each person who served as an executive officer of our company as of December 31, 2013:

Name and principal position	Outstanding Equity Awards at Fiscal Year-End									
	Option awards					Stock awards				
	Number of securities underlying unexercised options (#) Exercisable	Number of securities underlying unexercised options (#) Unexercisable	Equity incentive plan awards: Number of securities underlying unexercised options (#)	Options exercise price (\$)	Option expiration Date	Number of shares or units of stock that have not vested (#)	Market value of shares or units of stock that have not vested (\$)	Equity incentive plan awards: Number of shares other rights that have not vested (#)	Equity incentive plan awards: Market or payout value of unearned shares, units or other rights that have not vested (\$)	
James E. Taylor Chairman of the Board (1)	325,000	0	0	\$ 0.68	10/11/2015	0	\$ 0	0	\$ 0	
	1,200,000	0	0	\$ 0.72	12/8/2020	0	\$ 0	0	\$ 0	
	600,000	0	0	\$ 2.00	12/8/2015	0	\$ 0	0	\$ 0	
	375,000	125,000(a)	0	\$ 0.60	5/25/2016	0	\$ 0	0	\$ 0	
	500,000	0	0	\$ 2.00	5/25/2016	0	\$ 0	0	\$ 0	
	100,000	200,000(b)	0	\$ 0.15	8/10/2017	0	\$ 0	0	\$ 0	
Stephen S. Burns CEO and Director	600,000	0	0	\$ 0.40	5/12/2015	0	\$ 0	0	\$ 0	
	300,000	0	0	\$ 0.72	12/8/2020	0	\$ 0	0	\$ 0	
	300,000	0	0	\$ 2.00	12/8/2015	0	\$ 0	0	\$ 0	
	375,000	125,000(a)	0	\$ 0.60	5/25/2016	0	\$ 0	0	\$ 0	
	500,000	0	0	\$ 2.00	5/25/2016	0	\$ 0	0	\$ 0	
	100,000	0	0	\$ 0.25	5/2/2015	0	\$ 0	0	\$ 0	
	389,250	0	0	\$ 0.25	6/30/2015	0	\$ 0	0	\$ 0	
	102,000	198,000(c)	0	\$ 0.11	12/4/2015	0	\$ 0	0	\$ 0	
Martin J. Rucidlo President	200,000	0	0	\$ 0.40	5/12/2015	0	\$ 0	0	\$ 0	
	50,000	0	0	\$ 0.70	6/30/2013	0	\$ 0	0	\$ 0	
	90,000	210,000(d)	0	\$ 0.21	12/8/2015	0	\$ 0	0	\$ 0	
	85,000	165,000(e)	0	\$ 0.11	12/4/2015	0	\$ 0	0	\$ 0	
Richard J. Calme Interim CFO	50,000	0	0	\$ 0.40	5/12/2015	0	\$ 0	0	\$ 0	
	34,000	66,000(f)	0	\$ 0.11	12/4/2015	0	\$ 0	0	\$ 0	
Paul V. Gonzales CFO (2)	0	0				0	\$ 0	0	\$ 0	
Julio C. Rodriguez CFO	300,000	200,000(g)		\$ 0.40	8/6/2018	0	\$ 0	0	\$ 0	

(1) Resigned as CEO effective August 10, 2012

(2) Resigned as CFO effective May 16, 2012

(a) 125,000 options vest on 5/25/2013

(b) 100,000 options vest on 8/10/2013 and 8/10/2014

(c) 24,750 options vest every three months from 3/4/2013 to 12/4/2014

(d) 105,000 options vest on 8/24/2013 and 8/24/2014

- (e) 20,625 options vest every three months from 3/4/2013 to 12/4/2014
- (f) 8,250 options vest every three months from 3/4/2013 to 12/4/2014
- (g) 50,000 options vest every six months from 2/8/2014 to 2/8/2018

TABLE OF CONTENTS

Director Compensation

Name	Fees Earned or Paid in Cash \$	Stock Awards \$	Option Awards \$	Non-equity Incentive Plan Compensation \$	Change in Pension Value and Non- Qualified Deferred Compensation Earnings \$	All Other Compensation \$	Total (\$)
James E. Taylor	60,000	0	19,500	0	0	0	79,500
Raymond Chess	40,000		155,000	0	0	0	195,000

CERTAIN RELATIONSHIPS AND RELATED PERSON TRANSACTIONS

At no time during the last two fiscal years has any executive officer, director or any member of these individuals' immediate families, any corporation or organization with whom any of these individuals is an affiliate or any trust or estate in which any of these individuals serves as a trustee or in a similar capacity or has a substantial beneficial interest been indebted to the Company or was involved in any transaction in which the amount exceeded \$120,000 and such person had a direct or indirect material interest.

On May 23, 2014 Mr. Burns converted an aggregate of \$108,700 that Mr. Burns deposited and/or loaned to us into 1,087,000 shares of our common stock and a common stock purchase warrant to acquire 543,500 shares of common stock at \$0.15 per share.

Indemnification Provisions

We intend to enter into indemnification agreements with each of our directors and officers. These indemnification agreements, and our certificate of incorporation and bylaws, require us to indemnify our directors and officers to the fullest extent permitted by Nevada law.

Policies and Procedures for Transactions with Related Persons

After the effectiveness of the registration statement of which this prospectus forms a part, we expect that our audit committee will review for potential conflict of interest situations, on an ongoing basis, any future proposed transaction, or series of transactions, with related persons, and either approve or disapprove each reviewed transaction or series of related transactions with related persons.

In connection with the consummation of this offering, we expect to adopt a written policy and procedures with respect to related person transactions, which includes specific provisions for the approval of related person transactions. Pursuant to this policy, related person transactions include a transaction, arrangement or relationship or series of similar transactions, arrangements or relationships, in which we and certain enumerated related persons participate, the amount involved exceeds \$120,000 and the related person has a direct or indirect material interest.

TABLE OF CONTENTS

In the event that a related party transaction is identified, such transaction must be reviewed and approved or ratified by our audit committee. If it is impracticable for our audit committee to review such transaction, the transaction will be reviewed by the chair of our audit committee, whereupon the chair of our audit committee will report to the audit committee the approval or disapproval of such transaction.

In reviewing and approving related person transactions, the audit committee, or its chair, shall consider all information that the audit committee, or its chair, believes to be relevant and important to a review of the transaction. The audit committee or its chair, as the case may be, shall approve only those related person transactions that are determined to be in, or not inconsistent with, our best interests and that of our stockholders, taking into account all available relevant facts and circumstances available to the audit committee or the chair. These facts and circumstances will typically include, but not be limited to, the benefits of the transaction to us; the impact on a director's independence in the event the related person is a director, an immediate family member of a director or an entity in which a director is a partner, stockholder or executive officer; the availability of other sources for comparable products or services; the terms of the transaction; and the terms of comparable transactions that would be available to unrelated third parties or to employees generally. No member of the audit committee shall participate in any review, consideration or approval of any related person transaction with respect to which the member or any of his or her immediate family members is the related person.

SECURITY OWNERSHIP OF CERTAIN BENEFICIAL OWNERS AND MANAGEMENT

The following table sets forth certain information regarding the beneficial ownership of our common stock as of November 20, 2014, on an actual basis and as adjusted to reflect the sale of our common stock offered by this prospectus, by:

- our named executive officers;
- each of our directors;
- all of our current directors and executive officers as a group; and
- each stockholder known by us to own beneficially more than five percent of our common stock.

Beneficial ownership is determined in accordance with the rules of the Securities and Exchange Commission and includes voting or investment power with respect to the securities. Shares of common stock that may be acquired by an individual or group within 60 days of November 20, 2014, pursuant to the exercise of options or warrants, are deemed to be outstanding for the purpose of computing the percentage ownership of such individual or group, but are not deemed to be outstanding for the purpose of computing the percentage ownership of any other person shown in the table. Percentage of ownership is based on 149,667,926 shares of common stock outstanding on November 30, 2014, which does not reflect the assumed conversion of all of our outstanding 14% unsecured convertible notes. The percentage of beneficial ownership after the completion of this offering is based on _____ shares of common stock outstanding immediately after the closing of this offering, assuming no exercise of the underwriters' option to purchase shares of our common stock. Share amounts do not reflect the pro forma impact of the Reverse Stock Split.

Except as indicated in footnotes to this table, we believe that the stockholders named in this table have sole voting and investment power with respect to all shares of common stock shown to be beneficially owned by them, based on information provided to us by such stockholders. Unless otherwise indicated, the address for each director and executive officer listed is: c/o AMP Holding Inc., 100 Commerce Drive, Loveland, Ohio 45140.

Name of Beneficial Owner	Number of Shares Beneficially Owned	Percentage of Common Share Equivalents Beneficially Owned	
		Before Offering	After Offering
Stephen S. Burns *(1)	13,770,367	8.9%	
James E. Taylor *(2)	3,100,000	2.0%	
Julio Rodriguez *(3)	650,000	**	
Ray J. Chess *(4)	600,000	**	
Martin J. Rucidlo (5)	975,000	**	
Directors and Executive Officers as a group (5 persons)	19,095,513	11.9%	
Joseph T. Lukens (6)	44,331,301	28.4%	
Stephen D. Baksa (7)	25,776,941	16.5%	

* Executive officer and/or director of our company.

** Less than 1%.

- (1) Includes 7,673,367 shares of common stock held individually, 500,000 shares of common stock held by his wife and 5,597,146 shares of common stock issuable upon exercise of options and warrants at exercise prices ranging from \$0.15 to \$2.00.
- (2) Includes 3,100,000 shares of common stock issuable upon exercise of options and warrants at exercise prices ranging from \$0.15 to \$2.00.
- (3) Includes 650,000 shares of common stock issuable upon exercise of options at exercise prices ranging from \$0.04 to \$0.14.
- (4) Includes 100,000 shares of common stock issuable upon exercise of options at an exercise price of \$0.25 per share and 500,000 shares of common stock issuable upon exercise of options at an exercise price of \$0.26 per share
- (5) Includes 975,000 shares of common stock issuable upon exercise of options at exercise prices ranging from \$0.01 to \$0.70.
- (6) Includes 37,731,301 shares of common stock and common stock purchase warrants to acquire 6,600,000 shares of common stock at exercise prices in the range of \$0.15 and \$0.50.
- (7) Includes 19,376,941 shares of common stock and common stock purchase warrants to acquire 6,400,000 shares of common stock at exercise prices in the range of \$0.15 and \$0.50.

DESCRIPTION OF CERTAIN INDEBTEDNESS

Workhorse Debenture

On March 4, 2013, AMP Trucks entered into an Asset Purchase Agreement with Workhorse Custom Chassis, LLC (“Workhorse”), an Illinois limited liability company and a wholly-owned affiliate of Navistar International Corporation, to purchase certain assets including the Workhorse® brand, logo, intellectual property, patents and approximately 250,000 sq. ft. of facilities on 48 acres of land in Union City, Indiana (the “Assets”). On March 13, 2013, AMP Trucks closed the acquisition of the Assets from Workhorse for a purchase price of \$5,000,000 of which \$2,750,000 was paid in cash and the delivery of a Secured Debenture (the “Debenture”) in the principal amount of \$2,250,000. The Debenture is secured pursuant to a Security Agreement (the “Security Agreement”) and a Mortgage, Security Agreement, Assignment of Rents and Fixture Filing (the “Mortgage”) entered between AMP Trucks and Workhorse. Pursuant to the Security Agreement, AMP Trucks granted Workhorse a security interest in all of the assets of AMP Trucks in order to secure the prompt payment, performance and discharge in full of all of obligations of AMP Trucks under the Debenture. Pursuant to the Mortgage, the Debenture is secured by the real estate and related assets of the plant located in Union City, Indiana. The Debenture matures three years from its effective date of March 13, 2013 (the "Maturity Date") and interest associated with the Debenture is 10% per annum, which is payable on the Maturity Date. AMP Trucks may prepay outstanding principal and interest of the Debenture in full at any time. In the event AMP Trucks prepays outstanding principal and interest, it shall pay an amount equal to all outstanding principal and interest multiplied by 105%. AMP Holding and AMP guaranteed the payment of the Debenture.

14% Unsecured Convertible Debentures

From November 2014 through December 2014, we entered into Subscription Agreements with several accredited investors (the “2014 Investors”) providing for the sale by us to the 2014 Investors of 14% Unsecured Convertible Promissory Notes in the aggregate amount of \$[] (the "2014 Notes"). In addition to the 2014 Notes, the 2014 Investors also received common stock purchase warrants (the “2014 Warrants”) to acquire [] shares of common stock. The 2014 Warrants are exercisable for five years at an exercise price of \$0.14. Dawson James acted as placement agent.

DESCRIPTION OF CAPITAL STOCK

Authorized Capital

Our authorized capital stock consists of 250,000,000 shares of common stock, par value \$0.001 per share and 75,000,000 shares of preferred stock, par value \$0.001 per share. The following is a summary of the rights of our common and preferred stock and some of the provisions of our certificate of incorporation and bylaws, our outstanding warrants, outstanding options and Nevada corporate law. Because it is only a summary, it does not contain all the information that may be important to you. For a complete description you should refer to our certificate of incorporation, bylaws, the options and the warrants, copies of which have been filed as exhibits to the registration statement of which this prospectus is a part, as well as the relevant provisions of Nevada General Corporation Law.

Common Stock

As of November 20, 2014, there are 149,667,926 shares of common stock issued and outstanding, which does not give effect to the conversion of all the 14% unsecured convertible promissory notes into 6,428,571 shares of common stock. We have 94 stockholders of records. As of November 20, 2014, there were outstanding options to purchase 23,560,565 shares of common stock and warrants to purchase 53,417,613 shares of common stock.

Voting Rights. Holders of our common stock are entitled to one vote for each share of common stock held of record on all matters submitted to a vote of the holders of common stock. The affirmative vote of holders of at least a majority of the voting power of all of the then-outstanding shares of capital stock, voting as a single class, will be required to amend certain provisions of our certificate of incorporation, including provisions relating to removal of directors, director liability, vacancies on our board, special meetings, stockholder notices, actions by written consent and exclusive jurisdiction.

Dividends. Subject to preferences applicable to preferred stock, if any, each share of common stock is entitled to receive dividends as may be declared by our Board of Directors from time to time out of funds legally available therefor.

Liquidation. In the event of our liquidation, dissolution or winding up, the holders of common stock are entitled to share ratably in all assets remaining after payment in full of all of our creditors and payment of the liquidation preference of any outstanding preferred stock.

Rights and Preferences. Holders of our common stock have no preemptive, conversion, subscription or other rights, and there are no redemption or sinking fund provisions applicable to our common stock. The rights, preferences and privileges of the holders of our common stock are subject to and may be adversely affected by the rights of the holders of shares of any series of our preferred stock that we may designate in the future.

As of 2014, our Board intends to approve an amendment to our Articles of Incorporation to effect a reverse split of our common stock which we refer to as the Reverse Stock Split. Under NRS 78.207, the Board of Directors has the authority to reverse split the outstanding and authorized shares of common stock at an identical ratio solely based on the approval of the Board of Directors and without shareholder approval. Our Board is contemplating a Reverse Stock Split, at any time on or before with the final ratio to be determined at the discretion of our Board. Unless we indicate otherwise, the information in this prospectus does not reflect the pro forma impact of the Reverse Stock Split. If approved and implemented, the Reverse Stock Split will result in each shares of our outstanding stock automatically becoming one share, and any resulting fractional shares which will be rounded up to one whole share. As a result, following the consummation of the offering and after giving effect to the consummation of the proposed 1-for- Reverse Stock Split, and the sale by us of shares of common stock in this offering, we expect to have shares of common stock outstanding (if the underwriter exercises its over-allotment option in full) and no shares of preferred stock outstanding.

Preferred Stock

We have authorized 75,000,000 shares of preferred stock with a par value of \$.001 per share. These shares may be issued in series with such rights and preferences as may be determined by the Board of Directors. There are presently no outstanding shares of preferred stock outstanding.

Stock Options

As of November 20, 2014, options to purchase an aggregate of 23,560,565 shares of common stock were outstanding under the 2010 Stock Incentive Plan, 2011 Stock Incentive Plan, 2012 Stock Incentive Plan, the 2013 Stock Incentive Plan and the 2014 Stock Incentive Plan and 5,104,750 additional shares of common stock were available for future grants under such plans.

[TABLE OF CONTENTS](#)

Warrants

As of November 20, 2014, we had outstanding warrants to purchase 53,417,613 shares of common stock with a weighted average exercise price of \$0.22 per share.

Transfer Agent and Registrar

The stock transfer agent for our securities is Empire Stock Transfer, Inc., 1859 Whitney Mesa Drive, Henderson, Nevada 89014.

Stock Market Listing

We intend to change our name to Workhorse Advanced Vehicles Inc. and apply to list our common stock on the Nasdaq Capital Market (Nasdaq) under the symbol "WAV". No assurance can be given that such listing will be approved.

SHARES ELIGIBLE FOR FUTURE SALE

As of November 20, 2014, we had 149,667,926 shares of common stock outstanding, not including shares issuable upon exercise of our warrants or our options. All shares sold in this offering will be freely tradable without restriction or further registration under the Securities Act, unless they are purchased by our “affiliates,” as that term is defined in Rule 144 promulgated under the Securities Act.

The outstanding shares of our common stock not included in this prospectus will be available for sale in the public market as follows:

Public Float

Of our outstanding shares, as of November 20, 2014 approximately 65,281,609 shares are beneficially owned by executive officers, directors and affiliates (excluding shares of our common stock which may be acquired upon exercise of stock options and warrants which are currently exercisable or which become exercisable within 60 days of November 20, 2014). The approximately 84,386,317 remaining shares constitute our public float.

Rule 144

In general, under Rule 144 as currently in effect, as we have been subject to public company reporting requirements for 90 days, a person (or persons whose shares are aggregated) who is not deemed to have been an affiliate of ours at any time during the three months preceding a sale, and who has beneficially owned restricted securities within the meaning of Rule 144 for a least six months (including any period of consecutive ownership of preceding non-affiliated holders) would be entitled to sell those shares, subject only to the availability of current public information about us. A non-affiliated person who has beneficially owned restricted securities within the meaning of Rule 144 for at least six (6) months would be entitled to sell those shares without regard to the provisions of Rule 144.

In general, under Rule 144 as currently in effect, as we have been subject to public company reporting requirements for 90 days, our affiliates or persons selling shares on behalf of our affiliates who own shares that were acquired from us or an affiliate of ours at least six months prior to the proposed sale are entitled to sell upon expiration of the lock-up agreements described above, within any three-month period beginning 90 days after the date of this prospectus, a number of shares that does not exceed the greater of:

- 1% of the number of shares of common stock then outstanding, which will equal approximately shares immediately after this offering; or
- The average weekly trading volume of the common stock during the four calendar weeks preceding the filing of a notice on Form 144 with respect to such sale.

Sales under Rule 144 by our affiliates or persons selling shares on behalf of our affiliates are also subject to certain manner of sale provisions and notice requirements and to the availability of current public information about us.

<u>Days after the Date of this Prospectus</u>	<u>Approximate Number of Shares Eligible for Future Sale</u>	<u>Comment</u>
Upon effectiveness		Freely tradable shares sold in this offering
90 days		Shares eligible for resale under Rule 144 or 701
180 days		Lock-up releases; shares eligible for sales under Rules 144 or 701
Over 180 days		Restricted securities held for less than one year

Rule 144

Affiliate Resales of Restricted Securities

Affiliates of ours must generally comply with Rule 144 if they wish to sell any shares of our common stock in the public market, whether or not those shares are “restricted securities.” “Restricted securities” are any securities acquired from us or one of our affiliates in a transaction not involving a public offering. All shares of our common stock issued prior to the closing of the offering made hereby, are considered to be restricted securities. The shares of our common stock sold in this offering are not considered to be restricted securities.

Non-Affiliate Resales of Restricted Securities

Any person or entity who is not an affiliate of ours and who has not been an affiliate of ours at any time during the three months preceding a sale is only required to comply with Rule 144 in connection with sales of restricted shares of our common stock. Subject to the lock-up agreements described below, those persons may sell shares of our common stock that they have beneficially owned for at least one year without any restrictions under Rule 144 immediately following the effective date of the registration statement of which this prospectus is a part.

Further, beginning 90 days after the effective date of the registration statement of which this prospectus is a part, a person who is not an affiliate of ours at the time such person sells shares of our common stock, and has not been an affiliate of ours at any time during the three months preceding such sale, and who has beneficially owned such shares of our common stock, as applicable, for at least six months but less than a year, is entitled to sell such shares so long as there is adequate current public information, as defined in Rule 144, available about us.

Resales of restricted shares of our common stock by non-affiliates are not subject to the manner of sale, volume limitation or notice filing provisions of Rule 144, described above.

Rule 701

Rule 701 generally allows a stockholder who purchased shares of our common stock pursuant to a written compensatory plan or contract and who is not deemed to have been an affiliate of ours during the immediately preceding 90 days to sell these shares in reliance upon Rule 144, but without being required to comply with the public information, holding period, volume limitation, or notice provisions of Rule 144. Rule 701 also permits affiliates of ours to sell their Rule 701 shares under Rule 144 without complying with the holding period requirements of Rule 144. All holders of Rule 701 shares, however, are required to wait until 90 days after the date of this prospectus before selling such shares pursuant to Rule 701 and until expiration of the 180-day lock-up period described below.

Lock-Up Agreements

We and each of our directors and executive officers have agreed that, without the prior written consent of Dawson James Securities, Inc. on behalf of the underwriters, we and they will not, subject to limited exceptions, during the period ending 180 days after the date of this prospectus, subject to extension in specified circumstances:

- offer, pledge, sell or contract to sell, sell any option or contract to purchase, purchase any option or contract to sell, grant any option, right or warrant to purchase, lend, or otherwise transfer or dispose of, directly or indirectly, any shares of common stock or any securities convertible into or exercisable or exchangeable for common stock;
- enter into any swap or other arrangement that transfers to another, in whole or in part, any of the economic consequences of ownership of our common stock or any securities convertible into or exchangeable or exercisable for shares of our common stock, whether such transaction is to be settled by delivery of shares of our common stock or such other securities, in cash or otherwise;
- make any demand for or exercise any right with respect to the registration of any shares of our common stock or any securities convertible into or exchangeable or exercisable for shares of our common stock; or
- publicly announce an intention to do any of the foregoing.

The lock-up restrictions, specified exceptions and the circumstances under which the 180-day lock-up may be extended are described in more detail under “Underwriting.”

Material U.S. Federal Income Tax Considerations to U.S. Holders

This is a general summary of the material U.S. federal income tax consequences of the acquisition, ownership and disposition of our units, comprised of common stock and warrants, which we refer to collectively as our securities, purchased pursuant to this offering. This discussion assumes that holders will hold our securities as capital assets within the meaning of Section 1221 of the Code. This discussion does not address all aspects of U.S. federal taxation that may be relevant to a holder in light of such holder's particular circumstances. In addition, this discussion does not address: (1) U.S. gift or estate tax laws, (2) state, local or non-U.S. tax consequences or the consequences under any tax treaty, (3) the special tax rules that may apply to certain holders, including, without limitation, banks, insurance companies, financial institutions, broker-dealers, taxpayers that have elected mark-to-market accounting, taxpayers subject to the alternative minimum tax provisions of the Code, tax-exempt entities, regulated investment companies, real estate investment trusts, taxpayers whose functional currency is not the U.S. dollar, U.S. expatriates or former long-term residents of the United States, persons deemed to sell our common stock or warrants under the constructive sale provisions of the Code, persons who hold or receive our common stock or warrants pursuant to the exercise of any employee stock option or otherwise as compensation, tax-qualified retirement plans, persons that own, or are deemed to own, more than 5% of our outstanding common stock or warrants at any time, or personal holding companies, (4) the special tax rules that may apply to a holder that acquires, holds, or disposes of our securities as part of a straddle, hedge, wash sale, constructive sale or conversion transaction or other integrated investment, or (5) holders who are not U.S. holders as defined below. Additionally, this discussion does not address the tax consequences of the acquisition, ownership and disposition of our securities to partnerships (including entities treated as partnerships for U.S. federal tax purposes) or other pass-through entities or persons who hold our securities through such entities. The tax consequences of the acquisition, ownership and disposition of our securities to a partnership and each partner thereof generally will depend upon the status and activities of the partnership and such partner. Partnerships, other pass-through entities and persons holding our securities through such entities should consult their own tax advisors.

This discussion is based on current provisions of the Code, U.S. Treasury Regulations promulgated under the Code, judicial opinions, and published rulings and procedures of the U.S. Internal Revenue Service (the "IRS"), all as in effect on the date of this prospectus and all of which are subject to change, possibly with retroactive effect. We have not sought, and will not seek, any ruling from the IRS or any opinion of counsel with respect to the tax consequences discussed below, and there can be no assurance that the IRS will not take a position contrary to the tax consequences discussed below or that any position taken by the IRS would not be sustained.

Each prospective investor should consult its own tax advisors with respect to the U.S. federal, state, local and non-U.S. tax consequences to such investor of the acquisition, ownership and disposition of our securities.

General

For purposes of this discussion, a U.S. holder is:

- an individual citizen or resident alien of the United States;
- a corporation (or any other entity treated as a corporation for U.S. federal income tax purposes) created or organized in or under the laws of the United States, any state thereof or the District of Columbia;
- an estate the income of which is subject to U.S. federal income taxation regardless of its source; or
- a trust if (1) a court within the United States is able to exercise primary supervision over the administration of the trust and one or more United States persons have the authority to control all substantial decisions of the trust, or (2) the trust has a valid election in effect under applicable U.S. Treasury Regulations to be treated as a United States person.

There is no authority directly addressing the treatment, for U.S. federal income tax purposes, of securities with terms substantially the same as the units, and, therefore, that treatment is not entirely clear. Each unit should be treated for U.S. federal income tax purposes as an investment unit consisting of one share of our common stock and a Series A Warrant to acquire one-half (0.5) share of our common stock. Each holder of a unit must allocate the purchase price paid by such holder for such unit between the share of common stock and the Series A Warrant based on their respective relative fair market values. A holder's initial tax basis in the common stock and each Series A Warrant included in each unit should equal the portion of the purchase price of the unit allocated thereto.

The foregoing treatment of the common stock and warrants and a holder's purchase price allocation are not binding on the IRS or the courts. Because there are no authorities that directly address instruments that are similar to the units, no assurance can be given that the IRS or the courts will agree with the characterization described above or the discussion below. Accordingly, each prospective investor should consult its own tax advisors regarding the U.S. federal, state, local and any non-U.S. tax consequences of an investment in a unit (including alternative characterizations of a unit). Unless otherwise stated, the following discussions are based on the assumption that the characterization of the common stock and warrants described above is accepted for U.S. federal tax purposes.

Taxation of Distributions

If we pay distributions to holders of our common stock, such distributions generally will constitute dividends for U.S. federal income tax purposes to the extent paid from our current or accumulated earnings and profits, as determined under U.S. federal income tax principles. Distributions in excess of our current and accumulated earnings and profits will constitute a return of capital that will be applied against and reduce (but not below zero) the holder's adjusted tax basis in our common stock. Any remaining excess will be treated as gain realized on the sale or other disposition of the common stock and will be treated as described under "Gain or Loss on Sale, Exchange or Other Taxable Disposition of Common Stock" below. Provided certain holding period requirements are met and the holder refrains from making certain elections, dividends paid to a non-corporate holder generally will constitute "qualified dividends" that will be subject to tax at the maximum tax rate of 20% under current law.

Holders should consult their own tax advisors regarding the holding period and other requirements that must be satisfied in order to qualify for the reduced maximum tax rate on dividends.

Gain or Loss on Sale, Exchange or Other Taxable Disposition of Common Stock

In general, a holder must treat any gain or loss recognized upon a sale, exchange or other taxable disposition of our common stock as capital gain or loss. Any such capital gain or loss will be long-term capital gain or loss if the holder's holding period for the disposed of common stock exceeds one year. A reduced tax rate on capital gain generally will apply to long-term capital gain of a non-corporate holder. There are limitations on the deductibility of capital losses.

In general, a holder will recognize gain or loss in an amount equal to the difference between (1) the sum of the amount of cash and the fair market value of any property received in such disposition and (2) the holder's adjusted tax basis in the disposed of common stock. A holder's adjusted tax basis in its common stock generally will equal the holder's acquisition cost (that is, as discussed above, the portion of the purchase price of a unit allocated to a share of common stock) less any prior distributions treated as a return of capital, as described above.

Exercise of a Warrant

Except as discussed below with respect to the cashless exercise of a warrant, a holder will not be required to recognize taxable gain or loss upon exercise of a warrant. The holder's aggregate tax basis in the share of our common stock will be an amount equal to the sum of the holder's initial investment in the Series A Warrant (i.e., the portion of the holder's purchase price for a unit that is allocated to the Series A Warrant, as described above) and the exercise price. Subject to the discussion above, each holder must allocate such aggregate tax basis between the share of common stock received and the Series A Warrant based on their respective relative fair market values.

The tax consequences of a cashless exercise of a warrant are not clear under current tax law. A cashless exercise may be tax-free, either because the exercise is a non-recognition event or because the exercise is treated as a recapitalization for U.S. federal income tax purposes. It is also possible that a cashless exercise could be treated as a taxable exchange in which a holder would recognize gain or loss. In such event, a holder could be deemed to have surrendered warrants equal to the number of shares of common stock having a value equal to the exercise price for the total number of warrants to be exercised. The holder would recognize capital gain or loss in an amount equal to the difference between the fair market value of the common stock represented by the warrants deemed surrendered and the holder's tax basis in the warrants deemed surrendered.

If the cashless exercise were treated as a non-recognition event or as a taxable exchange, the holder's holding period in our common stock received upon exercise of the Series A Warrant would begin on the date following the date of exercise of the Series A Warrant and would not include the period during which the holder held the Series A Warrant. If the cashless exercise were treated as a recapitalization for U.S. federal income tax purposes, the holding period in our common stock received upon exercise of the Series A Warrant would include the holding period of the Series A Warrant.

Due to the absence of authority on the U.S. federal income tax treatment of a cashless exercise of warrants, there can be no assurance which, if any, of the alternative tax consequences described above would be adopted by the IRS or a court of law. Accordingly, holders should consult their own tax advisors regarding the tax consequences of a cashless exercise.

Sale, Exchange, Redemption or Expiration of a Warrant

Upon a sale, exchange (other than by exercise), redemption, or expiration of a warrant, a holder will be required to recognize gain or loss in an amount equal to the difference between (1) the amount realized upon such disposition or expiration and (2) the holder's tax basis in the warrant (that is, as discussed above, the portion of the holder's purchase price for a unit that is allocated to the warrant). Such gain or loss generally would be treated as long-term capital gain or loss if the warrant was held by the holder for more than one year at the time of such disposition or expiration. The deductibility of capital losses is subject to various limitations.

3.8% Tax on Net Investment Income

Section 1411 of the Code imposes a 3.8% net investment tax on certain net investment income earned by individuals, estates and trusts. For these purposes, net investment income generally includes dividends received and gain recognized with respect to our common stock or warrants. In the case of an individual, the tax will be imposed on the lesser of (i) the shareholder's net investment income or (ii) the amount by which the shareholder's modified adjusted gross income exceeds \$250,000 (if the shareholder is married and filing jointly or a surviving spouse), \$125,000 (if the shareholder is married and filing separately) or \$200,000 (in any other case). In the case of an estate or trust, the tax will be imposed on the lesser of (i) undistributed net investment income, or (ii) the excess adjusted gross income over the dollar amount at which the highest income tax bracket applicable to an estate or trust begins. Holders should consult their own tax advisors regarding the implications of this additional tax to their particular circumstances.

Foreign Account Tax Compliance Act

The Hiring Incentives to Restore Employment Act, which contains provisions originally proposed in the Foreign Account Tax Compliance Act ("FATCA"), was enacted on March 18, 2010, and will impose a 30% U.S. withholding tax on "withholdable payments" made to a foreign entity, which include payments of U.S.-source dividends and the gross proceeds from a disposition of property (such as our common stock or warrants) that can produce U.S.-source dividends unless (i) if the foreign entity is a "foreign financial institution," the foreign entity undertakes certain due diligence, reporting, withholding, and certification obligations, (ii) if the foreign entity is not a "foreign financial institution," the foreign entity identifies certain of its U.S. investors, if any, or (iii) the foreign entity is otherwise exempt under FATCA. An intergovernmental agreement between the United States and an applicable foreign country, or future Treasury Regulations, may modify these requirements. Under recently issued Treasury Regulations, withholding under FATCA will apply to payments of dividends on our common stock made after September 30, 2014, and to payments of gross proceeds from a sale or other disposition of our common stock or warrants made after December 31, 2016.

Prospective investors should consult their own tax advisors regarding the possible impact of the FATCA rules on their investment in our securities, and the entities through which they hold our securities, including, without limitation, the process and deadlines for meeting the applicable requirements to prevent the imposition of this 30% withholding tax under FATCA.

Information Reporting and Backup Withholding

We must report annually to the IRS and to each holder the amount of dividends or other distributions we pay to such holder on shares of our common stock and the amount of tax withheld with respect to those distributions, regardless of whether withholding is required. The gross amount of dividends and proceeds from the disposition of our common stock or warrants paid to a holder that fails to provide the appropriate certification in accordance with applicable U.S. Treasury regulations generally will be subject to backup withholding at the applicable rate, currently 28 percent.

Backup withholding is not an additional tax. Any amounts we withhold under the backup withholding rules may be refunded or credited against the holder's U.S. federal income tax liability, if any, by the IRS if the required information is furnished to the IRS in a timely manner.

THIS SUMMARY IS NOT A SUBSTITUTE FOR AN INDIVIDUAL ANALYSIS OF THE TAX CONSEQUENCES RELATING TO AN INVESTMENT IN THE UNITS. WE URGE YOU TO CONSULT YOUR OWN TAX ADVISOR CONCERNING THE U.S. FEDERAL INCOME TAX CONSEQUENCES TO YOU IN LIGHT OF YOUR FACTS AND CIRCUMSTANCES AND ANY CONSEQUENCES ARISING UNDER THE LAWS OF ANY STATE, LOCAL, FOREIGN OR OTHER TAXING JURISDICTION OR THE CONSEQUENCES UNDER ANY TAX TREATY.

UNDERWRITING

Dawson James Securities, Inc. is acting as the sole manager of the offering and as representative of the underwriters. Subject to the terms and conditions set forth in an underwriting agreement dated the date of this prospectus among us the representative of the underwriters named below, we have agreed to sell to the underwriters, and each underwriter has severally agreed to purchase from us, the number of units listed next to its name in the following table.

Underwriters	Number of Units
Dawson James Securities, Inc.	
Total	

The underwriters are committed to purchase all the units offered by us if they purchase any units. The underwriting agreement also provides that if an underwriter defaults, the purchase commitments of nondefaulting underwriters may be increased or the offering may be terminated. The underwriters are not obligated to purchase the shares, Series A Warrants or combinations thereof covered by the underwriters' over-allotment option described below. The underwriters are offering the units, subject to prior sale, when, as and if issued to and accepted by them, subject to approval of legal matters by their counsel, and other conditions contained in the underwriting agreement, such as the receipt by the underwriters of officer's certificates and legal opinions. The underwriters reserve the right to withdraw, cancel or modify offers to the public and to reject orders in whole or in part.

Discounts and Commissions

The underwriters propose initially to offer the units to the public at the public offering price set forth on the cover page of this prospectus and to dealers at that price less a concession not in excess of \$ per unit. After the initial offering of the units, the public offering price and other selling terms may be changed by the representative.

The following table shows the public offering price, underwriting discounts and commissions and proceeds before expenses to us. The information assumes either no exercise or full exercise of the over-allotment option we granted to the representative of the underwriters.

	Per Unit	Total Without Over- Allotment Option	Total With Over- Allotment Option
Public offering price	\$	\$	\$
Underwriting discounts and commissions			
Non-accountable expense allowance			
Proceeds, before expenses, to us			

(1) The price per unit of \$ includes \$0.005 for each warrant to purchase 0.5 shares of common stock included in such unit.

We have agreed to pay Dawson James Securities, Inc. a non-accountable expense allowance equal to 1% of the gross proceeds of the offering (excluding any proceeds from the over-allotment option, if any). We have agreed to reimburse the underwriters for all of its actual road show expenses. In addition, we have agreed to reimburse the expenses incurred by the underwriters in conducting its legal and diligence fees, up to a maximum amount of \$125,000. Any portion of the advance payment will be returned to us in the event not actually incurred.

The total estimated expenses of the offering, including registration, filing and listing fees, printing fees and legal and accounting expenses, but excluding underwriting discounts and commissions, are approximately \$ million and are payable by us.

Over-Allotment Option

We have granted to the underwriters an option to purchase up to (i) _____ additional shares of common stock at price of \$ _____ per share, which price reflects underwriting discounts and commissions, and/or (ii) _____ additional Series A Warrants at price of \$ _____ per Series A Warrant, which price reflects underwriting discounts and commissions. The over-allotment option may be used to purchase shares of common stock, Series A Warrants or any combination thereof, as determined by the underwriters, but such purchases cannot exceed an aggregate of 15% of the number of shares and Series A Warrants sold in the primary offering. The underwriters may exercise this option for 45 days from the date of this prospectus solely to cover sales of units by underwriters in excess of the total number of units set forth in the table above. If any of these additional securities are purchased, the underwriters will offer the additional units on the same terms as those on which the units are being offered. We will pay the expenses associated with the exercise of the over-allotment option.

Representative's Unit Purchase Option

We have also agreed to issue to the underwriters' Unit Purchase Options to purchase a number of our Units equal to an aggregate of 7% of the Units sold in this offering (excluding the over-allotment option). The underwriters' Unit Purchase Options will have an exercise price equal to 100% of the public offering price of the Units set forth on the cover of this prospectus and may be exercised on a cashless basis. The underwriters' Unit Purchase Options are not redeemable by us. This prospectus also covers the sale of the underwriters' Unit Purchase Options and the shares of common stock and Series A warrants issuable upon the exercise of the underwriters' Unit Purchase Options, as well as the shares underlying such Series A warrants. The underwriters' Unit Purchase Options and the underlying securities have been deemed compensation by FINRA, and are therefore subject to FINRA Rule 5110(g)(1). In accordance with FINRA Rule 5110(g)(1), neither the underwriters' Unit Purchase Options nor any shares of our common stock issued upon exercise of the underwriters' Unit Purchase Options may be sold, transferred, assigned, pledged, or hypothecated, or be the subject of any hedging, short sale, derivative, put, or call transaction that would result in the effective economic disposition of such securities by any person for a period of 180 days immediately following the date of effectiveness or commencement of sales of the offering pursuant to which the underwriters' Unit Purchase Options are being issued, except the transfer of any security:

- by operation of law or by reason of reorganization of our company;
- to any FINRA member firm participating in this offering and the officers or partners thereof, if all securities so transferred remain subject to the lock-up restriction described above for the remainder of the time period;
- if the aggregate amount of our securities held by either an underwriter or a related person do not exceed 1% of the securities being offered;
- that is beneficially owned on a pro-rata basis by all equity owners of an investment fund, provided that no participating member manages or otherwise directs investments by the fund, and participating members in the aggregate do not own more than 10% of the equity in the fund; or
- the exercise or conversion of any security, if all securities received remain subject to the lock-up restriction set forth above for the remainder of the time period.

In addition, in accordance with FINRA Rule 5110(f)(2)(G), the underwriters' Unit Purchase Options may not contain certain anti-dilution terms.

Right of First Refusal

Subject to certain conditions, we granted the representative of the underwriters in this offering, for a period of 12 months after the date of the effectiveness of this registration statement, a right of first refusal to act as sole book-running manager for any future equity, equity-linked or debt offerings.

Indemnification

We have agreed to indemnify the underwriters against certain liabilities, including liabilities under the Securities Act, and to contribute to payments that the underwriters may be required to make for these liabilities.

Price Stabilization, Short Positions and Penalty Bids

In connection with the offering, the underwriters may engage in stabilizing transactions, over-allotment transactions, syndicate covering transactions and penalty bids in accordance with Regulation M under the Exchange Act:

- Stabilizing transactions permit bids to purchase the underlying security so long as the stabilizing bids do not exceed a specified maximum.
- Over-allotment involves sales by the underwriters of securities in excess of the number of securities the underwriters are obligated to purchase, which creates a syndicate short position. The short position may be either a covered short position or a naked short position. In a covered short position, the number of securities over-allotted by the underwriters is not greater than the number of securities that they may purchase in the over-allotment option. In a naked short position, the number of securities involved is greater than the number of securities in the over-allotment option. The underwriters may close out any covered short position by either exercising their over-allotment option and/or purchasing securities in the open market.
- Syndicate covering transactions involve purchases of securities in the open market after the distribution has been completed in order to cover syndicate short positions. In determining the source of securities to close out the short position, the underwriters will consider, among other things, the price of securities available for purchase in the open market as compared to the price at which it may purchase such securities through the over-allotment option. If the underwriters sell more securities than could be covered by the over-allotment option, a naked short position, the position can only be closed out by buying securities in the open market. A naked short position is more likely to be created if the underwriters are concerned that there could be downward pressure on the price of the securities in the open market after pricing that could adversely affect investors who purchase in the offering.
- Penalty bids permit the underwriters to reclaim a selling concession from a syndicate member when a security originally sold by the syndicate member is purchased in a stabilizing or syndicate covering transaction to cover syndicate short positions.

These stabilizing transactions, syndicate covering transactions and penalty bids may have the effect of raising or maintaining the market price of our common stock or preventing or retarding a decline in the market price of our common stock. As a result, the price of our common stock may be higher than the price that might otherwise exist in the open market. Neither we nor the underwriters make any representation or prediction as to the direction or magnitude of any effect that the transactions described above may have on the price of the common stock. In addition, neither we nor the underwriters make any representations that the underwriters will engage in these stabilizing transactions or that any transaction, once commenced, will not be discontinued without notice.

Electronic Offer, Sale and Distribution of Shares

A prospectus in electronic format may be made available on the websites maintained by one or more underwriters or selling group members, if any, participating in the offering. The underwriters may agree to allocate a number of shares of common stock to underwriters and selling group members for sale to their online brokerage account holders. Internet distributions will be allocated by the representative to underwriters and selling group members that may make Internet distributions on the same basis as other allocations. Other than the prospectus in electronic format, the information on the underwriters' websites and any information contained in any other website maintained by the underwriters is not part of this prospectus or the registration statement of which this prospectus forms a part.

Other Relationships

From time to time, certain of the underwriters and their affiliates have provided, and may provide in the future, various advisory, investment and commercial banking and other services to us in the ordinary course of business, for which they have received and may continue to receive customary fees and commissions. In connection with our private placement of the 2014 Notes, Dawson James Securities, Inc. acted as placement agent for the offering. We paid Dawson James Securities, Inc. a placement agent fee of 8% of the proceeds from such offering, and a non-accountable allowance of 1% of the gross proceeds, provided that for any placements made to our existing shareholders, Dawson James Securities, Inc. received a placement agent fee of 4.5% of the gross proceeds. In addition, we agreed to issue Dawson James Securities, Inc. a placement agent warrant to purchase 9% of the aggregate number of securities sold in the private placement.

Offer restrictions outside the United States

Other than in the United States, no action has been taken by us or the underwriters that would permit a public offering of the securities offered by this prospectus in any jurisdiction where action for that purpose is required. The securities offered by this prospectus may not be offered or sold, directly or indirectly, nor may this prospectus or any other offering material or advertisements in connection with the offer and sale of any such securities be distributed or published in any jurisdiction, except under circumstances that will result in compliance with the applicable rules and regulations of that jurisdiction. Persons into whose possession this prospectus comes are advised to inform themselves about and to observe any restrictions relating to the offering and the distribution of this prospectus. This prospectus does not constitute an offer to sell or a solicitation of an offer to buy any securities offered by this prospectus in any jurisdiction in which such an offer or a solicitation is unlawful.

Notice to Prospective Investors in the European Economic Area

In relation to each Member State of the European Economic Area which has implemented the Prospectus Directive (each, a “Relevant Member State”), each underwriter represents and agrees that with effect from and including the date on which the Prospectus Directive is implemented in that Relevant Member State, it has not made and will not make an offer of shares which are the subject of the offering contemplated by this prospectus to the public in that Relevant Member State other than:

- (a) to any legal entity which is a qualified investor as defined in the Prospectus Directive;
- (b) to fewer than 100 or, if the Relevant Member State has implemented the relevant provision of the 2010 PD Amending Directive, 150, natural or legal persons (other than qualified investors as defined in the Prospectus Directive), as permitted under the Prospectus Directive, subject to obtaining the prior consent of the representatives for any such offer; or
- (c) in any other circumstances falling within Article 3(2) of the Prospectus Directive, provided that no such offer of shares shall require us or any underwriter to publish a prospectus pursuant to Article 3 of the Prospectus Directive.

For the purposes of this provision, the expression an “offer to the public” in relation to any shares in any Relevant Member State means the communication in any form and by any means of sufficient information on the terms of the offer and the shares to be offered so as to enable an investor to decide to purchase or subscribe the shares, as the same may be varied in that Member State by any measure implementing the Prospectus Directive in that Member State, the expression Prospectus Directive means Directive 2003/71/EC (and amendments thereto, including the 2010 PD Amending Directive, to the extent implemented in the Relevant Member State), and includes any relevant implementing measure in the Relevant Member State and the expression “2010 PD Amending Directive” means Directive 2010/73/EU.

Notice to Prospective Investors in the United Kingdom

Each of the underwriters severally represents, warrants and agrees as follows:

- (a) it has only communicated or caused to be communicated and will only communicate or cause to be communicated an invitation or inducement to engage in investment activity (within the meaning of Section 21 of the Financial Services and Markets Act 2000, or FSMA) received by it in connection with the issue or sale of the shares in circumstances in which Section 21 of the FSMA does not apply to us; and
- (b) it has complied with, and will comply with, all applicable provisions of the FSMA with respect to anything done by it in relation to the shares in, from or otherwise involving the United Kingdom.

Notice to Prospective Investors in France

Neither this prospectus nor any other offering material relating to the shares described in this prospectus has been submitted to the clearance procedures of the Autorité des Marchés Financiers or of the competent authority of another member state of the European Economic Area and notified to the Autorité des Marchés Financiers. The shares have not been offered or sold and will not be offered or sold, directly or indirectly, to the public in France. Neither this prospectus nor any other offering material relating to the shares has been or will be:

- (a) released, issued, distributed or caused to be released, issued or distributed to the public in France; or
- (b) used in connection with any offer for subscription or sale of the shares to the public in France.

Such offers, sales and distributions will be made in France only:

- (a) to qualified investors (investisseurs qualifiés) and/or to a restricted circle of investors (cercle restreint d’investisseurs), in each case investing for their own account, all as defined in, and in accordance with articles L.411-2, D.411-1, D.411-2, D.734-1, D.744-1, D.754-1 and D.764-1 of the French Code monétaire et financier;

TABLE OF CONTENTS

(b) to investment services providers authorized to engage in portfolio management on behalf of third parties; or

(c) in a transaction that, in accordance with article L.411-2-II-1^o-or-2^o-or 3^o of the French Code monétaire et financier and article 211-2 of the General Regulations (Règlement Général) of the Autorité des Marchés Financiers, does not constitute a public offer (appel public à l'épargne). The shares may be resold, directly or indirectly, only in compliance with articles L.411-1, L.411-2, L.412-1 and L.621-8 through L.621-8-3 of the French Code monétaire et financier.

LEGAL MATTERS

The validity of the issuance of the common stock offered by us in this offering will be passed upon for us by Fleming PLLC, Rockville Centre, New York. Schiff Hardin LLP, Washington, DC, is acting as counsel for the underwriters in connection with certain legal matters in connection with this offering.

EXPERTS

The audited financial statements of AMP Holding Inc. as of and for the years ended December 31, 2013 and 2012 included in this prospectus have been so included in reliance on the report of Clark Schaefer Hackett & Company, an independent registered public accounting firm, given on the authority of said firm as experts in auditing and accounting. The report on the financial statements contains an explanatory paragraph describing conditions that raise substantial doubt regarding our ability to continue as a going concern, as described more fully in Note 1 to the audited financial statements.

WHERE YOU CAN FIND MORE INFORMATION

We have filed with the Securities and Exchange Commission a registration statement on Form S-1 under the Securities Act with respect to the common stock offered by this prospectus. This prospectus, which is part of the registration statement, omits certain information, exhibits, schedules and undertakings set forth in the registration statement. For further information pertaining to us and our common stock, reference is made to the registration statement and the exhibits and schedules to the registration statement. Statements contained in this prospectus as to the contents or provisions of any documents referred to in this prospectus are not necessarily complete, and in each instance where a copy of the document has been filed as an exhibit to the registration statement, reference is made to the exhibit for a more complete description of the matters involved.

You may read and copy all or any portion of the registration statement without charge at the public reference room of the Securities and Exchange Commission at 100 F Street, N.E., Washington, D.C. 20549. Copies of the registration statement may be obtained from the Securities and Exchange Commission at prescribed rates from the public reference room of the Securities and Exchange Commission at such address. You may obtain information regarding the operation of the public reference room by calling 1-800-SEC-0330. In addition, registration statements and certain other filings made with the Securities and Exchange Commission electronically are publicly available through the Securities and Exchange Commission's website at <http://www.sec.gov>. The registration statement, including all exhibits and amendments to the registration statement, has been filed electronically with the Securities and Exchange Commission.

We file periodic reports and other information with the SEC. Such periodic reports and other information are available for inspection and copying at the public reference room and website of the SEC referred to above. We maintain a website at <http://www.AMPElectricVehicles.com>. You may access our annual reports on Form 10-K, quarterly reports on Form 10-Q, current reports on Form 8-K, and amendments to those reports filed or furnished pursuant to Section 13(a) or 15(d) of the Exchange Act with the SEC free of charge at our website as soon as reasonably practicable after such material is electronically filed with, or furnished to, the SEC. The information and other content contained on our website are not part of the prospectus.

FINANCIAL STATEMENTS
AMP HOLDING INC.
INDEX TO FINANCIAL STATEMENTS

Contents

Consolidated Balance Sheets as of September 30, 2014 and December 31, 2014	F-2
Consolidated Statement of Operations for the Three and Nine Months Ended September 30, 2014 and 2013 and for the Period from Inception to September 30, 2014	F-3
Consolidated Statements of Stockholders' Equity (Deficit) from Inception, February 20, 2007 to September 30, 2014	F-4
Consolidated Statement of Cash Flows for the Three and Nine Months Ended September 30, 2014 and 2013 and for the Period from Inception to September 30, 2014	F-5
Notes to Consolidated Financial Statements (Unaudited) – September 30, 2014	F-7
Report of Independent Registered Public Accounting Firm	F-19
Balance Sheets as of December 31, 2013 and 2012	F-20
Statement of Operations for the Years Ended December 31, 2013 and 2012 and for the Period from Inception to December 31, 2013	F-21
Statements of Stockholders' Equity (Deficit) from Inception, February 20, 2007, to December 31, 2013	F-22
Statement of Cash Flows for the Three and Nine Months Ended September 30, 2014 and 2013 and for the Period from Inception, February 20, 2007, to December 31, 2013	F-23
Notes to Consolidated Financial Statements (Unaudited) – September 30, 2014	F-25

AMP Holding Inc.
(A Development Stage Company)
Consolidated Balance Sheets
September 30, 2014 and December 31, 2013

Assets	September 30, 2014 (Unaudited)	December 31, 2013
Current assets:		
Cash and cash equivalents	\$ 833,834	\$ 7,019
Inventory	392,750	392,750
Prepaid expenses and deposits	70,965	43,967
	<u>1,297,549</u>	<u>443,736</u>
Property, plant and equipment, net	4,112,685	4,407,261
	<u>\$ 5,410,234</u>	<u>\$ 4,850,997</u>
Liabilities and Stockholders' Equity (Deficit)		
Current liabilities:		
Accounts payable	\$ 1,369,206	\$ 1,546,388
Accounts payable, related parties	353,642	468,165
Customer deposits	-	177,500
Shareholder advances	-	1,934,300
Current portion of long-term debt	37,548	338,225
	<u>\$ 1,760,396</u>	<u>\$ 4,464,578</u>
Long-term debt	2,495,244	2,292,890
Stockholders' equity (deficit):		
Series A preferred stock, par value of \$.001 per share 75,000,000 shares authorized, 0 shares issued and outstanding at December 31, 2013 and December 31, 2012	-	-
Common stock, par value of \$.001 per share 250,000,000 shares authorized, 149,057,350 shares issued and outstanding at September 30, 2014 and 82,711,524 shares issued and outstanding at December 31, 2013	149,051	82,712
Additional paid-in capital	26,992,044	20,321,536
Stock based compensation	6,456,211	5,171,093
Accumulated deficit during the development stage	(32,442,712)	(27,481,812)
	<u>1,154,594</u>	<u>(1,906,471)</u>
	<u>\$ 5,410,234</u>	<u>\$ 4,850,997</u>

See accompanying notes to financial statements.

AMP Holding Inc.
(A Development Stage Company)
Consolidated Statements of Operations
For the Three and Nine Months Ended September 30, 2014 and 2013
and for the Period From Inception,
February 20, 2007 to September 30, 2014
(Unaudited)

	Three Months Ended September 30		Nine Months Ended September 30		Since Date of Inception, February 20, 2007 to September 30, 2014
	2014	2013	2014	2013	2014
Sales	\$ -	\$ 177,500	\$ 177,459	\$ 177,500	\$ 957,799
Operating Expenses					
Selling, general and administrative	797,195	585,205	2,521,695	2,504,110	17,267,669
Research and development	895,669	562,425	2,364,686	2,285,637	15,365,276
Total operating expenses	1,692,864	1,147,630	4,886,381	4,789,746	32,632,945
Interest expense, net	95,001	75,034	251,978	179,029	767,566
Net loss during the development stage	\$ (1,787,865)	\$ (1,045,164)	\$ (4,960,900)	\$ (4,791,275)	\$ (32,442,712)
Basic and diluted loss per share	\$ (0.01)	\$ (0.01)	\$ (0.03)	\$ (0.07)	
Weighted average number of common shares outstanding	149,057,350	80,655,861	149,057,350	73,164,046	

See accompanying notes to financial statements.

2009	-	-	-	-	-	-	-	(1,524,923)	(1,524,923)
	<u>17,772,449</u>	<u>\$ 17,772</u>	<u>8,375</u>	<u>\$ 8</u>	<u>\$ 2,843,460</u>	<u>\$ -</u>	<u>\$ -</u>	<u>\$ (3,364,952)</u>	<u>\$ (503,712)</u>
Conversion of convertible note	29,750	30	-	-	9,970	-	-	-	10,000
Issuance of preferred stock, and fulfillment of stock subscriptions receivable	-	-	625	1	24,999	-	-	-	25,000
Issuance of common stock, and fulfillment of stock subscriptions receivable	9,808,566	9,809	-	-	3,682,530	-	-	-	3,692,339
Conversion of account payable	101,636	102	-	-	86,898	-	-	-	87,000
Share based compensation for the year ended December 31, 2010	-	-	-	-	-	1,436,979	-	-	1,436,979
Net loss from operations for the year ended December 31, 2010	-	-	-	-	-	-	-	(5,028,106)	(5,028,106)
	<u>27,712,401</u>	<u>\$ 27,713</u>	<u>9,000</u>	<u>\$ 9</u>	<u>\$ 6,647,857</u>	<u>\$ 1,436,979</u>	<u>\$ -</u>	<u>\$ (8,393,058)</u>	<u>\$ (280,500)</u>
Issuance of common stock, and fulfillment of stock subscriptions receivable	9,912,447	9,911	-	-	5,404,830	-	-	-	5,414,741
Stock options and warrants exercised	38,692	39	-	-	12,236	-	-	-	12,275
Conversion of preferred stock to common stock	1,071,110	1,072	(9,000)	(9)	(1,063)	-	-	-	-
Share based compensation for the year ended December 31, 2011	-	-	-	-	-	2,002,891	-	-	2,002,891
Net loss from operations for the year ended December 31, 2011	-	-	-	-	-	-	-	(8,705,711)	(8,705,711)
	<u>38,734,650</u>	<u>\$ 38,735</u>	<u>-</u>	<u>\$ -</u>	<u>\$ 12,063,860</u>	<u>\$ 3,439,870</u>	<u>\$ -</u>	<u>\$ (17,098,769)</u>	<u>\$ (1,556,304)</u>
Issuance of detached warrants in connection with convertible debentures	-	-	-	-	91,493	-	-	-	91,493
Conversion of debentures and interest	10,227,070	10,227	-	-	2,035,187	-	-	-	2,045,414
Conversion of account payable	6,993,743	6,993	-	-	766,007	-	-	-	773,000
Share based compensation for the year ended December 31, 2012	-	-	-	-	-	338,853	-	-	338,853
Net loss from operations for the year ended December 31, 2012	-	-	-	-	-	-	-	(4,272,489)	(4,272,489)
	<u>55,955,463</u>	<u>\$ 55,955</u>	<u>-</u>	<u>\$ -</u>	<u>\$ 14,956,547</u>	<u>\$ 3,778,723</u>	<u>\$ -</u>	<u>\$ (21,371,258)</u>	<u>\$ (2,580,033)</u>

Issuance of common stock, and fulfillment of stock subscriptions receivable	21,330,000	21,330	-	-	4,254,270	-	-	4,275,600
Stock options and warrants exercised	18,764	20	-	-	1,143	-	-	1,163
Conversion of convertible note	500,000	500	-	-	99,500	-	-	100,000
Conversion of account payable	4,907,297	4,907	-	-	1,010,076	-	-	1,014,983
Share based compensation for the year ended December 31, 2013	-	-	-	-	-	1,392,370	-	1,392,370
Net loss from operations for the year ended December 31, 2013	-	-	-	-	-	-	(6,110,554)	(6,110,554)
	<u>82,711,524</u>	<u>\$ 82,712</u>	<u>-</u>	<u>\$ -</u>	<u>\$ 20,321,536</u>	<u>\$ 5,171,093</u>	<u>\$ (27,481,812)</u>	<u>\$ (1,906,471)</u>
Issuance of common stock, and fulfillment of stock subscriptions receivable	59,423,000	59,423	-	-	5,882,877	-	-	5,942,300
Stock options and warrants exercised								
Conversion of account payable	6,922,826	6,916	-	-	787,631	-	-	794,547
Share based compensation for the year ended September 30, 2014	-	-	-	-	-	1,285,118	-	1,285,118
Net loss from operations for the year ended September 30, 2014	-	-	-	-	-	-	(4,960,900)	(4,960,900)
	<u>149,057,350</u>	<u>149,051</u>	<u>-</u>	<u>-</u>	<u>26,992,044</u>	<u>6,456,211</u>	<u>(32,442,712)</u>	<u>1,154,594</u>

See accompanying notes to financial statements.

[TABLE OF CONTENTS](#)

AMP Holding Inc.
(A Development Stage Company)
Consolidated Statements of Cash Flows
For the Three and Nine Months Ended September 30, 2014 and 2013
and for the Period From Inception,
February 20, 2007 to September 30, 2014
(Unaudited)

	Three Months Ended September 30		Nine Months Ended September 30		Since Date of Inception, February 20, 2007 to September 30, 2014
	2014	2013	2014	2013	2014
Cash flows from operating activities:					
Net loss during the development stage	\$ (1,787,865)	\$ (1,045,164)	\$ (4,960,900)	\$ (4,791,275)	\$ (32,442,712)
Adjustments to reconcile net loss from operations to cash used by operations:					
Depreciation	91,590	101,491	294,576	218,155	907,232
Loss on sale of assets	-	-	-	-	27,544
Stock based compensation	534,004	32,652	1,285,118	1,173,179	6,473,951
Interest expense on convertible debentures	-	-	13,269	-	172,228
Amortized discount on convertible debentures	-	-	-	-	91,493
Legal, consulting and investment services	239,763	256,940	794,547	859,515	2,810,875
Capitalization of accrued interests	-	-	225,000	-	225,000
Effects of changes in operating assets and liabilities:					
Inventory	-	47,250	-	47,250	7,250
Prepaid expenses and deposits	(22,729)	(36,103)	(26,998)	(80,879)	(70,965)
Accounts payable	594,878	64,324	451,977	156,404	2,512,000
Accounts payable, related parties	(612,872)	25,187	(756,951)	39,981	(341,581)
Customer deposits	-	(177,500)	(177,500)	142,500	-
Net cash used by operations	<u>(963,231)</u>	<u>(730,923)</u>	<u>(2,857,862)</u>	<u>(2,235,170)</u>	<u>(19,627,685)</u>
Cash flows from investing activities:					
Cash paid in acquisition of Workhorse Custom Chasis, LLC	-	-	-	(2,750,000)	(2,750,000)
Capital expenditures	-	(63)	-	(63)	(376,713)
Proceeds on sale of assets	-	-	-	-	38,900
Net cash used by investing activities	<u>-</u>	<u>(63)</u>	<u>-</u>	<u>(2,750,063)</u>	<u>(3,087,813)</u>
Cash flows from financing activities:					
Proceeds from debentures	-	-	-	-	1,939,250
Proceeds from notes payable	-	-	-	100,000	160,000
Payments on notes payable	-	-	-	-	(150,000)
Proceeds from long-term debt	-	-	-	-	50,000
Payments on long-term debt	(3,111)	(62,895)	(323,323)	(103,884)	(554,207)
Conversion of note payable	-	-	-	-	-
Shareholder advances, net of repayments	(6,000)	655,000	(1,934,300)	655,000	-
Issuance of common and preferred stock	-	-	5,942,300	4,301,761	22,104,289
Net cash provided by financing activities	<u>(9,111)</u>	<u>592,105</u>	<u>3,684,677</u>	<u>4,952,877</u>	<u>23,549,332</u>
Change in cash and cash equivalents	(972,342)	(138,881)	826,815	(32,356)	833,833
Cash at the beginning of the period	1,806,176	146,344	7,019	39,819	-
Cash at the end of the period	<u>833,834</u>	<u>7,463</u>	<u>833,834</u>	<u>7,463</u>	<u>833,833</u>

TABLE OF CONTENTS

Supplemental disclosure of non-cash activities:

Vehicles valued at \$61,284 were contributed as consideration for issuance of common stock in February 2007.

Consulting services valued at \$50,000 were accepted as consideration for issuance of common stock in October 2008.

During March 2010 a note payable of \$10,000 was converted to 29,750 shares of common stock.

A vehicle valued at \$33,427 was acquired through bank financing in September 2010.

Consulting services valued at \$87,000 were accepted as consideration for issuance of common stock in December 2010.

Equipment valued at \$14,937 was acquired through debt financing in December 2011.

Consulting services valued at \$60,000, \$55,000, and \$203,000 were accepted as consideration for issuance of common stock in March, October, and December 2012, respectively.

Detachable warrants associated with convertible debentures valued at \$91,493 were recorded as increases to additional paid-in capital from January to August 2012.

Investment Agreement fees valued at \$375,000 were accepted as consideration for issuance of common stock in August 2012.

Legal services valued at \$40,000, \$15,000, and \$25,000 were accepted as consideration for issuance of common stock in September, November, and December 2012, respectively.

During November 2012 debentures for \$1,939,250 and interest of \$106,164 were converted to 10,227,070 shares of common stock.

During December 2012 accounts payable of \$513,636 were converted to notes payable.

During February 2013 a note payable of \$100,000 was converted to 500,000 shares of common stock.

During March 2013, the Company entered into a note payable in the amount of \$2,250,000 related to the acquisition of Workhorse Custom Chassis, LLC. See note 2 to the financial statements.

Consulting services valued at \$302,500, \$126,000, \$119,075, \$11,750, and \$155,000 were accepted as consideration for issuance of common stock in March, May, June, July, and September 2013, respectively.

Legal services valued at \$40,000, \$15,000, \$5,000, and \$5,000 were accepted as consideration for issuance of common stock in March, June, July, and August 2013, respectively.

Rent expense valued at \$80,190 was accepted as consideration for issuance of common stock in March, June, July, and August 2013, respectively.

See accompanying notes to financial statements.

AMP Holding Inc.

**Notes to Consolidated Financial Statements
(Unaudited)**

1. SUMMARY OF SIGNIFICANT ACCOUNTING PRINCIPLES

The following accounting principles and practices are set forth to facilitate the understanding of data presented in the financial statements:

Nature of operations and principles of consolidation

AMP Holding Inc. (AMP, we, us or our) designs, develops, manufacture, and sells high-performance, medium-duty trucks with advanced powertrain components under the Workhorse chassis brand.

AMP Holding Inc., formerly known as Title Starts Online, Inc. (the Company), incorporated in the State of Nevada in 2007 with \$3,100 of capital from the issuance of common shares to the founding shareholder. On August 11, 2008 the Company received a Notice of Effectiveness from the U.S. Securities and Exchange Commission, and on September 18, 2008, the Company closed a public offering in which it accepted subscriptions for an aggregate of 200,000 shares of its common stock, raising \$50,000 less offering costs of \$46,234. With this limited capital the Company did not commence operations and remained a “shell company” (as defined in Rule 12b-2 under the Securities Exchange Act of 1934, as amended).

On December 28, 2009, the Company entered into and closed a Share Exchange Agreement with the Shareholders of Advanced Mechanical Products, Inc. (n/k/a AMP Electric Vehicles, Inc.) (AMP) pursuant to which the Company acquired 100% of the outstanding securities of AMP in exchange for 14,890,904 shares of the Company’s common stock. Considering that, following the merger, the AMP Shareholders control the majority of the outstanding voting common stock of the Company, and effectively succeeded the Company’s otherwise minimal operations to those that are AMP. AMP is considered the accounting acquirer in this reverse-merger transaction. A reverse-merger transaction is considered and accounted for as a capital transaction in substance; it is equivalent to the issuance of AMP securities for net monetary assets of the Company, which are de minimus, accompanied by a recapitalization. Accordingly, goodwill or other intangible assets have not been recognized in connection with this reverse merger transaction. AMP is the surviving entity and the historical financials following the reverse merger transaction will be those of AMP. The Company was a shell company immediately prior to the acquisition of AMP pursuant to the terms of the Share Exchange Agreement. As a result of such acquisition, the Company operations are now focused on the design, marketing and sale of modified vehicles with an all-electric power train and battery systems. Consequently, we believe that acquisition has caused the Company to cease to be a shell company as it now has operations. The Company formally changed its name to AMP Holding Inc. on May 24, 2010.

Since the acquisition, the Company has devoted the majority of its resources to the development of an all-electric drive system capable of moving heavy large vehicles ranging from full size SUV’s up to and including Medium Duty Commercial trucks. Additionally, in February 2013, AMP Holding Inc. formed a new wholly owned subsidiary, AMP Trucks Inc., an Indiana corporation. On March 13, 2013 AMP Trucks Inc. closed on the acquisition of an asset purchase of Workhorse Custom Chassis, LLC. The assets included in this transaction included: the Workhorse brand, access to the dealer network of 440 dealers nationwide, intellectual property, and all physical assets which included the approximately 250,000 sq. ft. of facilities on 48 acres of land in Union City, Indiana. This acquisition allows AMP Holding Inc. to position itself as a medium duty OEM capable of producing new chassis with electric, propane, compressed natural gas, and hybrid configurations, as well as gasoline drive systems. Revenues since the inception of the Company, February 20, 2007, through the date of these financial statements have not been significant and consist of customer vehicle conversions and sales of converted experimental vehicles.

Development-stage Company

Based on the Company's business plan, it is a development stage company since planned principal operations resulting in revenue have not fully commenced. Accordingly, the Company presents its financial statements in conformity with the accounting principles generally accepted in the United States of America that apply to developing enterprises. As a development stage enterprise, the Company discloses its retained earnings (or deficit accumulated) during the development stage and the cumulative statements of operations and cash flows from commencement of development stage to the current balance sheet date. The development stage began in 2007 when the Company was organized.

TABLE OF CONTENTS

Basis of presentation

The financial statements have been prepared on a going concern basis, which contemplates the realization of assets and liquidation of liabilities in the normal course of business. However, the Company has limited revenues and has negative working capital and stockholders' deficits. These conditions raise substantial doubt about the ability of the Company to continue as a going concern.

In view of these matters, continuation as a going concern is dependent upon the continued operations of the Company, which in turn is dependent upon the Company's ability to meet its financial requirements, raise additional capital, and the success of its future operations. The financial statements do not include any adjustments to the amount and classification of assets and liabilities that may be necessary should the Company not continue as a going concern.

The Company has continued to raise capital. Management believes the proceeds from these offerings, future offerings, and the Company's anticipated revenue provides an opportunity to continue as a going concern. If additional funding is required, the Company plans to obtain working capital from either debt or equity financing from the sale of common, preferred stock, and/or convertible debentures. Obtaining such working capital is not assured.

The preparation of financial statements in conformity with generally accepted accounting principles requires management to make estimates and assumptions that affect the amounts reported in the financial statements and accompanying notes. Actual results could differ from these estimates.

Certain reclassifications were made to the prior year financial statements to conform to the current year presentation. These reclassifications had no effect on previously reported results of operation or stockholders' equity (deficit).

Financial instruments

The carrying amounts of financial instruments including cash, inventory, accounts payable and short-term debt approximate fair value because of the relatively short maturity of these instruments.

Inventory

Inventory is stated at the lower of cost or market.

Property and depreciation

Property and equipment is recorded at cost. Major renewals and improvements are capitalized while replacements, maintenance and repairs, which do not improve or extend the lives of the respective assets, are expensed. When property and equipment is retired or otherwise disposed of, a gain or loss is realized for the difference between the net book value of the asset and the proceeds realized thereon. Depreciation is calculated using the straight-line method, based upon the following estimated useful lives:

- Buildings: 15 - 30 years
- Leasehold improvements: 7 years
- Software: 3 - 6 years
- Equipment: 5 years
- Vehicles and prototypes: 3 - 5 years

Capital stock

On April 22, 2010, the directors of the Company approved a forward stock split of the common stock of the Company on a 14:1 basis. On May 12, 2010, the stockholders of the Company voted to approve the amendment of the certificate of incorporation resulting in a decrease of the number of shares of Common stock. The Company filed a 14c definitive information statement with the Securities and Exchange Commission and mailed the same to its shareholders. Management filed the certificate of amendment decreasing the authorized shares of common stock with the State of Nevada on September 8, 2010.

TABLE OF CONTENTS

The capital stock of the Company is as follows:

Preferred Stock - The Company has authorized 75,000,000 shares of preferred stock with a par value of \$.001 per share. These shares may be issued in series with such rights and preferences as may be determined by the Board of Directors. The Series A Stock is convertible, at any time at the option of the holder, into common shares of the Company based on a conversion price of \$0.336 per share. The holders of the Series A Stock are not entitled to convert the Series A Stock and receive shares of common stock such that the number of shares of common stock held by them in the aggregate and their affiliates after such conversion or exercise does not exceed 4.99% of the then issued and outstanding shares of common stock. The Series A Stock has voting rights on an as converted basis, does not pay dividends, and does not provide any liquidation rights.

Common Stock - The Company has authorized 250,000,000 shares of common stock with a par value of \$.001 per share.

Revenue recognition / customer deposits

It is the Company's policy that revenues will be recognized in accordance with SEC Staff Bulletin (SAB) No. 104, "Revenue Recognition". Under SAB 104, product revenues (or service revenues) are recognized when persuasive evidence of an arrangement exists, delivery has occurred (or service has been performed), the sales price is fixed and determinable, and collectability is reasonably assured. Customer deposits include monies from customers to reserve a production slot for conversion of an OEM power train to the AMP all electric power train. The final retail price and delivery date are yet to be determined. Customer deposits are subject to a full refund at the request of the customer.

Income taxes

With the consent of its shareholders, at the date of inception, AMP elected under the Internal Revenue Code to be taxed as an S corporation. Since shareholders of an S corporation are taxed on their proportionate share of the Company's taxable income, an S corporation is generally not subject to either federal or state income taxes at the corporate level. On December 28, 2009 pursuant to the merger transaction the Company revoked its election to be taxed as an S-corporation.

As no taxable income has occurred from the date of this merger to September 30, 2014 cumulative deferred tax assets of approximately \$7.8 million are fully reserved, and no provision or liability for federal or state income taxes has been included in the financial statements. Net operating losses of approximately \$ 3.6 million are available for carryover to be used against taxable income generated through 2030, net operating losses of approximately \$6.7 million are available for carryover to be used against taxable income generated through 2031, and net operating losses of approximately \$3.9 million are available for carryover to be used against taxable income generated through 2032, net operating losses of approximately \$4.7 million are available for carryover to be used against taxable income generated through 2033, and net operating losses of approximately \$4 million are available for carryover to be used against taxable income generated through 2034. The Company had not filed income tax returns during its period as a shell company.

Uncertain tax positions

The Company adopted the provisions of Accounting for Uncertainty in Income Taxes. Those provisions clarify the accounting and recognition for income tax positions taken or expected to be taken in the Company's income tax returns. The Company's income tax filings are subject to audit by various taxing authorities. The years of filings open to these authorities and available for audit are 2011 - 2013. The Company's policy with regard to interest and penalties is to recognize interest through interest expense and penalties through other expense. No interest or penalties with regard to income tax filings were incurred in any period, including 2014 or 2013, or since the period of inception, February 20, 2007. In evaluating the Company's tax provisions and accruals, future taxable income, and the reversal of temporary differences, interpretations and tax planning strategies are considered. The Company believes their estimates are appropriate based on current facts and circumstances.

Research and development costs

The Company expenses research and development costs as they are incurred. Research and Development costs were approximately \$2.4 million and \$2.3 million for the nine month period ended September 30, 2014 and 2013, and \$15.4 million for the period of inception to September 30, 2014, consisting primarily of personnel costs for our teams in engineering and research, prototyping expense, and contract and professional services. Union City plant expenses prior to the start of production are also included in research and development expenses.

TABLE OF CONTENTS

Basic and diluted loss per share

Basic loss per share is computed by dividing net loss available to common shareholders (numerator) by the weighted average number of shares outstanding (denominator) during the period. For all periods, all of the Company's common stock equivalents were excluded from the calculation of diluted loss per common share because they were anti-dilutive, due to the Company's net losses.

Stock based compensation

The Company accounts for its stock based compensation in accordance with "Share-Based Payments" (codified in FASB ASC Topic 718 and 505). The Company recognizes in its statement of operations the grant-date fair value of stock options and warrants issued to employees and non-employees. The fair value is estimated on the date of grant using a lattice-based valuation model that uses assumptions concerning expected volatility, expected term, and the expected risk-free rate of return. For the awards granted, the expected volatility was estimated by management as 50% based on a range of forecasted results. The expected term of the awards granted was assumed to be the contract life of the option or warrant (one, two, three, five or ten years as determined in the specific arrangement). The risk-free rate of return was based on market yields in effect on the date of each grant for United States Treasury debt securities with a maturity equal to the expected term of the award.

Related party transactions

Certain stockholders and stockholder family members have advanced funds or performed services for the Company. These services are believed to be at market rates for similar services from non-related parties. Related party accounts payable are segregated in the balance sheet.

Subsequent events

We have received orders from a national fleet for 18 full electric vehicles to be delivered during 2015. We also have orders for 2 E-Gen vehicles for the same company that we plan to deliver for customer testing in Q1 2015.

2. PROPERTY, PLANT AND EQUIPMENT

As of September 30, 2014 and December 31, 2013, our property, plant and equipment, net, consisted of the following:

	September 30, 2014	December 31, 2013
Land	300,000	300,000
Buildings	3,800,000	3,800,000
Leasehold Improvements	19,225	19,225
Software	27,721	27,721
Equipment	670,183	670,183
Vehicles and prototypes	164,959	164,959
	<u>4,982,088</u>	<u>4,982,088</u>
Less accumulated depreciation	(869,403)	(574,827)
	<u><u>4,112,685</u></u>	<u><u>4,407,261</u></u>

TABLE OF CONTENTS

On March 13, 2013 the Company acquired the operating assets of Workhorse Custom Chassis, LLC, an unrelated company located in Union City, Indiana. The following summarizes the consideration paid, and the components of the purchase price and the related allocation of assets acquired and liabilities assumed.

Consideration

Cash at closing	\$ 2,750,000
Secured debenture	2,250,000
	<u>\$ 5,000,000</u>

Assets acquired

Inventory	\$ 400,000
Equipment	500,000
Land	300,000
Buildings	3,800,000
	<u>\$ 5,000,000</u>

Valuation methods used for the identifiable assets acquired in the acquisition make use of fair value measurements based on unobservable inputs and reliance on management's assumptions that similar market participants would use in pricing the assets. As such, the fair value measurements represent a Level 3 input.

3. LONG-TERM DEBT

Long-term debt consists of the following:

	September 30, 2014	December 31, 2013
Secured debenture payable to Workhorse Custom Chassis, LLC, due March 2016 plus interest at 10%. The debenture is secured by the real estate and related assets of the plant located in Union City, Indiana with a net book value of \$4,070,006 at September 30, 2014	2,475,000	2,250,000
Note payable, Bank due in monthly installments of \$635 including interest at 5.04% with the final payment due August 2015. The note is secured by equipment with a net book value of \$6,134 at September 30, 2014	6,573	11,928
Note payable, vendor due in monthly installments of \$439 including interest at 8.00% with the final payment due December 2014. The note is secured by equipment with a net book value of \$6,534 at September 30, 2014	1,219	5,051
Note payable to the City of Loveland, due in annual installments of \$10,241 including interest with the final payment due October 2016. Interest rate amended to 8.00%. The note is unsecured and contains restrictions on the use of proceeds.	50,000	50,000
Note payable, vendor due in monthly installments of \$5,000 for the first half of 2013. Note paid on March 2014.	-	123,736
Note payable, vendor due in monthly installments of \$2,000 plus interest at 4% for the first half of 2013, escalating to final payment of \$18,461 plus interest at 4% in December 2014. Note paid on May 2014.	-	190,400
	2,532,792	2,631,115
Less current portion	37,548	356,868
Long term debt	<u>2,495,244</u>	<u>2,274,247</u>

TABLE OF CONTENTS

Aggregate maturities of long-term debt are as follows:

2014	37,548
2015	2,495,244
2016	-
	<u>2,532,792</u>

The note payable to the City of Loveland contains job creation incentives whereby each annual payment may be forgiven by the City upon the Company meeting minimum job creation benchmarks. This loan agreement amended the incentives to 30 full time employees within the City of Loveland with payroll totaling \$135,000 by October 31, 2013 and 40 employees with payroll totaling \$175,000 by July 31, 2014, continuing with an average of 40 employees with payroll totaling \$175,000 thereafter. The proceeds from this loan were to be used for qualified disbursements only, and the Company has been notified it did not meet the requirements for qualified disbursements and for forgiveness of the 2012 principal and interest payment, which is past due. In 2013 the Company made payments to an escrow account totaling \$22,900.

4. CONVERTIBLE DEBENTURES

From January 6, 2012 through August 3, 2012, the Company entered into Securities Purchase Agreements and Security Agreements with several accredited investors (the "2012 Investors") providing for the sale by the Company to the 2012 Investors of Secured Convertible Debentures in the aggregate amount of \$1,939,250 (the "2012 Notes"). The Company received the proceeds in connection with these financings between January 6, 2012 and August 3, 2012. Further a shareholder, director and officer converted secured and unsecured loans provided to the Company from September 30, 2011 to June 5, 2012 in the aggregate amount of \$389,250 into the 2012 Notes and 2012 Warrants. The 2012 Notes were to mature one year from their respective effective dates (the "Maturity Dates") and interest associated with the 2012 Notes was 10% per annum, payable on the Maturity Dates. In November 2012, the Company entered into a Note and Warrant Amendment and Conversion Agreement whereby the holders and the 2012 Investors converted all principal and interest under the 2012 Notes into 10,227,070 shares of common stock. Further, the exercise price of the 2012 Warrants was reduced to \$0.25 per share.

In addition to the 2012 Notes, the 2012 Investors also received common stock purchase warrants (the "2012 Warrants") to acquire 1,939,250 shares of common stock of the Company. The 2012 Warrants are exercisable for three years at an exercise price of \$0.50 per share, reduced to \$0.25 per share as noted above. The value of the detachable 2012 Warrants was determined using a lattice-based valuation model that used an expected volatility, estimated by management as 50% based on a range of forecasted results, and an expected risk-free rate of return, based on market yields in effect on the grant dates for United States Treasury debt securities with a three year maturity. The \$91,493 value of the detachable 2012 Warrants was recorded as an increase in additional paid-in capital and a discount against the 2012 Notes. The discount on the 2012 notes was amortized as interest expense during the period that the 2012 Notes were outstanding. Amortization charged to the Statement of Operations is \$91,493 for the year ended December 31, 2012.

The 2012 Notes and the 2012 Warrants carry standard anti-dilution provisions but in no event may the conversion price be reduced below \$0.25. Further, the 2012 Investors will have the right to participate in the next financing on a pro-rata basis up to \$1,000,000.

5. SHAREHOLDER AND RELATED PARTY ADVANCES

Investor advances are as follows:

September 30, 2014	December 31, 2013	Rate	Date	Expire	Note
-	43,000	3%	11 /30/2009	3 /31/2012	1
-	15,000	10%	10 /5/2012	10 /5/2013	1
-	100,000	10%	10 /16/2012	10 /16/2013	1
-	100,000	10%	10 /16/2012	10 /16/2013	1
-	50,000	10%	10 /19/2012	10 /19/2013	1
-	50,000	10%	11 /2/2012	11 /2/2013	1
-	50,000	10%	11 /8/2012	11 /8/2013	1
-	100,000	10%	12 /6/2012	12 /6/2013	1
-	50,000	10%	12 /19/2012	12 /19/2013	1
-	3,200	10%	10 /10/2013	10 /10/2014	1
-	2,500	10%	11 /5/2013	11 /5/2014	1
-	200,000	10%	11 /12/2013	11 /12/2014	1
-	50,000	10%	12 /2/2013	12 /2/2014	1
-	50,000	10%	12 /30/2013	12 /30/2014	1
-	80,000		12 /11/2013		2
-	990,600		Various 2013/14		3
-	<u>1,934,300</u>				

- 1 Advances were converted into equity during the second quarter of 2014
- 2 Paid on March 8, 2014.
- 3 Various non-interest bearing shareholders' deposits converted into equity third quarter 2014.

6. LEASE OBLIGATIONS

On October 1, 2011 the Company began leasing operating facilities under an agreement expiring on September 30, 2018. Future minimum monthly lease payments under the agreement are currently \$12,598 and increase 3% in October of each year. Prepaid expenses and deposits include a security deposit equal to \$12,275. Aggregate maturities of lease obligations are as follows:

2014	38,928
2015	156,881
2016	161,588
2017	166,435
2018	127,614
	<u>651,446</u>

Total rent expense under these operating type leases for the nine months ended September 30, 2014 and 2013 was \$113 thousand and \$110 thousand, respectively, and \$713 thousand for the period from inception to September 30, 2014.

7. STOCK BASED COMPENSATION

Options to directors, officers and employees

The Company maintains, as adopted by the board of directors, the 2013 Incentive Stock Plan, the 2012 Incentive Stock Plan, the 2011 Incentive Stock Plan and the 2010 Stock Incentive Plan (the plans) providing for the issuance of up to 11,000,000 options to employees, officers, directors or consultants of the Company. Incentive stock options granted under the plans may only be granted with an exercise price of not less than fair market value of the Company's common stock on the date of grant (110% of fair market value for incentive stock options granted to principal stockholders). Non-qualified stock options granted under the plans may only be granted with an exercise price of not less than 85% of the fair market value of the Company's common stock on the date of grant. Awards under the plans may be either vested or unvested options. The unvested options vest ratably over two years for options with a five or three year term and after one year for options with a two year term.

In addition to the plans, the Company has granted, on various dates, stock options to directors, officers and employees to purchase common stock of the Company. The terms, exercise prices and vesting of these awards vary.

[TABLE OF CONTENTS](#)

The following table summarizes option activity for directors, officers and employees:

	Outstanding Stock Options				
	Shares Available for Grant	Number of Shares	Weighted Average Exercise Price per Share	Weighted Average Grant Date Fair Value per Share	Weighted Average Remaining Exercise Term in Months
Balance, December 31 2012	6,080,000	6,420,874	\$ 0.50	\$ 0.25	46
Additional stock reserved	-	-	-	-	-
Granted	(2,100,000)	2,100,000	\$ 0.29	0.12	47
Exercised	-	(21,126)	0.11	-	29
Forfeited	-	-	-	-	-
Expired	505,000	(505,000)	0.70	0.20	-
Balance, December 31, 2013	4,485,000	7,994,748	\$ 0.51	\$ 0.23	36
Additional stock reserved	3,000,000	-	-	-	-
Granted	(5,480,674)	5,480,674	\$ 0.01	0.09	66
Exercised	-	-	-	-	-
Forfeited	-	-	-	-	-
Expired	-	-	-	-	-
Balance, September 30, 2014	2,004,326	13,475,422	\$ 0.30	\$ 0.19	33

The Company recorded \$502,625, \$434,387 and \$ 2,710,766 compensation expense for stock options to directors, officers and employees for the nine months ended September 30, 2014, 2013 and the period from inception (February 20, 2007) to September 30, 2014, respectively. As of September 30, 2014, unrecognized compensation expense of \$496,335 is related to non-vested options granted to directors, officers and employees which is anticipated to be recognized over the next 30 months, commensurate with the vesting schedules.

[TABLE OF CONTENTS](#)

Options to consultants

The Company has also granted, on various dates, stock options to purchase common stock of the Company to consultants for services previously provided to the Company. The terms, exercise prices and vesting of these awards vary.

The following table summarizes option activity for consultants:

	Shares Available for Grant	Number of Shares	Outstanding Stock Options		
			Weighted Average Exercise Price per Share	Weighted Average Grant Date Fair Value per Share	Weighted Average Remaining Exercise Term in Months
Balance, December 31 2012	561,000	1,825,000	\$ 0.57	\$ 0.23	21
Additional stock reserved	-	-	-	-	-
Granted	(400,000)	400,000	0.21	0.10	56
Exercised	-	-	-	-	-
Forfeited	-	-	-	-	-
Expired	810,000	(810,000)	0.67	0.23	-
Balance, December 31, 2013	971,000	1,415,000	\$ 0.41	\$ 0.20	34
Additional stock reserved	2,500,000	-	-	-	-
Granted	(2,451,967)	2,451,967	0.01	0.09	66
Exercised	-	-	-	-	-
Forfeited	-	-	-	-	-
Expired	190,000	(190,000)	\$ 0.50	\$ 0.17	-
Balance, September 30, 2014	1,209,033	3,676,967	\$ 0.14	\$ 0.13	53

The Company recorded \$113,091, \$68,747 and \$277,832 compensation expense for stock options to consultants for the nine months ended September 30, 2014, 2013 and for the period from inception (February 20, 2007) to September 30, 2014, respectively. As of September 30, 2014, unrecognized compensation expense of \$200,798 is related to non-vested options granted to consultants which is anticipated to be recognized over the next 14 months, commensurate with the vesting schedules.

Warrants to accredited investors

From December 2010 through December 2011, common stock sold by the Company included common stock purchase warrants to acquire shares of common stock of the Company. For each ten shares sold, each investor received a warrant to purchase five shares of common stock for a period of two years at an exercise price of \$0.80 per share. In November 2012, the purchase warrants were modified to change the exercise period from two years to three years. The \$112 cost of this modification is included in stock based compensation expense for the year ended December 31, 2012.

From January 2012 through August 2012, the 2012 Investors received 2012 Warrants to acquire common stock of the Company. The 2012 Warrants are exercisable for three years at an exercise price of \$0.50. In November 2012, the Company entered into a Note and Warrant Amendment and Conversion Agreement whereby the holders and the 2012 Investors converted all principal and interest under the 2012 Notes into shares of common stock. Further, the exercise price of the 2012 Warrants was reduced to \$0.25 per share. The \$20,795 cost of the reduction in the exercise price for accredited investors is included in stock based compensation expense for the year ended December 31, 2012.

From January 2013 through May 2013, investors received warrants to acquire common stock of the Company that are exercisable for three years at an exercise price of \$0.40.

During June 2013, investors received warrants to acquire common stock of the Company that are exercisable for three years at an exercise price of \$0.64.

The above securities were offered and sold to the investors in private placement transactions made in reliance upon exemptions from registration pursuant to Section 4(2) under the Securities Act of 1933 (the “Securities Act”) and/or Rule 506 promulgated under the Securities Act. The investors are accredited investors as defined in Rule 501 of Regulation D promulgated under the Securities Act.

The following table summarizes warrant activity for accredited investors:

	Shares Available for Grant	Outstanding Warrants			
		Number of Shares	Weighted Average Exercise Price per Share	Weighted Average Grant Date Fair Value per Share	Weighted Average Remaining Exercise Term in Months
Balance, December 31 2012	7,191,225	8,694,547	\$ 0.76	\$ 0.13	19
Additional stock reserved	3,000,000				
Granted	(10,954,063)	10,954,063	0.40	0.05	27
Exercised	-	-	-	-	-
Forfeited	-	-	-	-	-
Expired	1,901,666	(1,901,666)	0.85	0.15	-
Balance, December 31, 2013	1,138,828	17,746,944	\$ 0.54	\$ 0.08	15
Additional stock reserved	30,000,000				
Granted	(29,711,500)	29,711,500	\$ 0.15	\$ 0.02	41
Exercised	-	-	-	-	-
Forfeited	-	-	-	-	-
Expired	4,164,547	(4,164,547)	\$ 0.80	\$ 0.11	-
Balance, September 30, 2014	5,591,875	43,293,897	\$ 0.25	\$ 0.04	27

The Company recorded \$669,402, \$902,342 and \$2,225,825 compensation expense for stock warrants to accredited investors for the nine months ended September 30, 2014, 2013 and for the period from inception (February 20, 2007) to September 30, 2014, respectively. There is no unrecognized compensation expense for these warrants because they are fully vested at date of grant.

[TABLE OF CONTENTS](#)

Warrants to placement agent and consultants

Through December 2011, the Company compensated the placement agent for assisting in the sale of the Company's securities by paying the placement agent commissions and issuing the placement agent common stock purchase warrants to purchase shares of the Company's common stock. The warrants have a five year term and various exercise prices.

The Company has also granted, on various dates, stock warrants to purchase common stock of the Company to consultants for services previously provided to the Company. The terms, exercise prices and vesting of these awards vary.

The following table summarizes warrant activity for the placement agent and consultants:

	Shares Available for Grant	Number of Shares	Outstanding Warrants		
			Weighted Average Exercise Price per Share	Weighted Average Grant Date Fair Value per Share	Weighted Average Remaining Exercise Term in Months
Balance, December 31 2012	4,339,590	3,130,894	\$ 0.46	\$ 0.21	36
Additional stock reserved	-	-	-	-	-
Granted	-	-	-	-	-
Exercised	-	-	-	-	-
Forfeited	-	-	-	-	-
Expired	-	-	-	-	-
Balance, December 31, 2013	4,339,590	3,130,894	\$ 0.46	\$ 0.21	24
Additional stock reserved	-	-	-	-	-
Granted	-	-	-	-	-
Exercised	-	-	-	-	-
Forfeited	-	-	-	-	-
Expired	-	-	-	-	-
Balance, September 30, 2014	4,339,590	3,130,894	\$ 0.46	\$ 0.21	15

The Company recorded \$0, \$0 and \$936,340 compensation expense for stock warrants to the placement agent and consultants for the nine months ended September 30, 2014, 2013 and for the period from inception (February 20, 2007) to September 30, 2014, respectively. There is no unrecognized compensation expense for the placement agent warrants because they are fully vested at date of grant.

Warrants to directors and officers

In December 2010 and May 2011, the Company issued to certain directors and officers common stock purchase warrants to acquire shares of common stock at an exercise price of \$2.00 per share for a period of five years. In November 2011, under the terms of a Promissory Note issued to a director and officer, common stock purchase warrants were issued to acquire 100,000 shares of common stock at an exercise price of \$0.50 per share for a period of one year. In May 2012, a director and officer received 100,000 2012 Warrants to acquire common stock of the Company at an exercise price of \$0.50 for a period of three years. In June 2012, a director and officer converted secured and unsecured loans provided to the Company from September 2011 to June 2012 in the aggregate amount of \$389,250 into 2012 Notes and 2012 Warrants. In November 2012, the Company entered into a Note and Warrant Amendment and Conversion Agreement whereby the holders and 2012 Investors converted all principal and interest under the 2012 Notes into shares of common stock. Further, the exercise price of the 2012 Warrants was reduced to \$0.25 per share. The \$7,388 cost of the reduction in the exercise price is included in stock based compensation expense for the year ended December 31, 2012.

The following table summarizes warrant activity for directors and officers:

	Outstanding Warrants				
	Shares Available for Grant	Number of Shares	Weighted Average Exercise Price per Share	Weighted Average Grant Date Fair Value per Share	Weighted Average Remaining Exercise Term in Months
Balance, December 31 2012	3,389,250	3,489,250	\$ 1.75	\$ 0.09	29
Additional stock reserved	-	-	\$ -	-	-
Granted	-	-	-	-	-
Exercised	-	-	-	-	-
Forfeited	-	-	-	-	-
Expired	100,000	(100,000)	0.50	0.10	-
Balance, December 31, 2013	3,489,250	3,389,250	\$ 1.78	\$ 0.09	22
Additional stock reserved	-	-	-	-	-
Granted	-	-	-	-	-
Exercised	-	-	-	-	-
Forfeited	-	-	-	-	-
Expired	-	-	-	-	-
Balance, September 30, 2014	3,489,250	3,389,250	\$ 1.78	\$ 0.09	13

The Company recorded \$0, \$0 and \$323,188 compensation expense for stock warrants to directors and officers for the nine months ended September 30, 2014, 2013 and for the period from inception (February 20, 2007) to September 30, 2014, respectively. There is no unrecognized compensation expense for these warrants because they are fully vested at date of grant.

8. RECENT PRONOUNCEMENTS

In June 2014, The FASB issued ASU No. 2014-12, Compensation – Stock Compensation (Topic 718): Accounting for Share-Based Payments When the Terms of an Award Provide That a Performance Target Could Be Achieved after the Requisite Service Period. The amendments in the ASU require that a performance target that affects vesting and that could be achieved after the requisite service period be treated as a performance condition. A reporting entity should apply existing guidance in Topic 718, Compensation – Stock Compensation, as it relates to awards with performance conditions that affect vesting to account for such awards. The amendments in this ASU are effective for annual periods and interim periods within those annual periods beginning after December 15, 2015. Earlier adoption is permitted. The effective date is the same for both public business entities and all other entities. We do not expect the adoption of these provisions to have a significant impact on the Company’s consolidated financial statements.

In May 2014, The FASB issued ASU No. 2014-09, Revenue from Contracts with Customers: Topic 606. ASU 2014-09 affects any entity using U.S. GAAP that either enters into contracts with customers to transfer goods or services or enters into contracts for the transfer of nonfinancial assets unless those contracts are within the scope of other standards (e.g., insurance contracts or lease contracts). For a public entity, the amendments in this ASU are effective for annual reporting periods beginning after December 15, 2016, including interim periods within that reporting period. Early application is not permitted. We do not expect the adoption of these provisions to have a significant impact on the Company’s consolidated financial statements.



REPORT OF INDEPENDENT REGISTERED PUBLIC ACCOUNTING FIRM

We have audited the accompanying balance sheets of AMP Holding Inc. (A Development Stage Company) as of December 31, 2013 and 2012 and the related statements of operations, stockholders' equity (deficit), and cash flows for the years then ended and for the period from inception, February 20, 2007, to December 31, 2013. These financial statements are the responsibility of the company's management. Our responsibility is to express an opinion on these financial statements based on our audits.

We conducted our audits in accordance with the standards of the Public Company Accounting Oversight Board (United States). Those standards require that we plan and perform the audit to obtain reasonable assurance about whether the financial statements are free of material misstatement. The company is not required to have, nor were we engaged to perform, an audit of its internal control over financial reporting. Our audit included consideration of internal control over financial reporting as a basis for designing audit procedures that are appropriate in the circumstances, but not for the purpose of expressing an opinion on the effectiveness of the company's internal control over financial reporting. Accordingly, we express no such opinion. An audit also includes examining, on a test basis, evidence supporting the amounts and disclosures in the financial statements, assessing the accounting principles used and significant estimates made by management, as well as evaluating the overall financial statement presentation. We believe that our audits provide a reasonable basis for our opinion.

In our opinion, the financial statements referred to above present fairly, in all material respects, the financial position of AMP Holding Inc. as of December 31, 2013 and 2012, and the results of its operations and its cash flows for the years then ended and for the period from inception, February 20, 2007, to December 31, 2013 in conformity with accounting principles generally accepted in the United States of America.

The accompanying financial statements have been prepared assuming the Company will continue as a going concern. As described in note 1, the Company has not had significant sales and has negative working capital and stockholder's deficits, which raise substantial doubt about its ability to continue as a going concern. Management's plan in regard to this matter is also discussed in note 1. The financial statements do not include any adjustments that might result from the outcome of these uncertainties.

Clark, Schaefer, Hackett & Co.

Cincinnati, Ohio
April 15, 2014

one east fourth street, suite 1200
cincinnati, ohio 45202

www.cshco.com
p. 513.241.3111
f. 513.241.1212

cincinnati | cleveland | columbus | miami valley | northern Kentucky | springfield | toledo

AMP Holding Inc.
(A Development Stage Company)
Balance Sheets
December 31, 2013 and 2012

	<u>December 31,</u> 2013	<u>December 31,</u> 2012
Assets		
Current assets:		
Cash and cash equivalents	\$ 7,019	\$ 39,819
Inventory	392,750	41,002
Prepaid expenses and deposits	43,967	13,025
	<u>443,736</u>	<u>93,846</u>
Property, plant and equipment:		
Land	300,000	-
Buildings	3,800,000	-
Leasehold improvements	19,225	19,225
Software	27,721	27,721
Equipment	670,183	170,120
Vehicles and prototypes	164,959	164,959
	<u>4,982,088</u>	<u>382,025</u>
Less accumulated depreciation	574,827	255,178
	<u>4,407,261</u>	<u>126,847</u>
	<u>\$ 4,850,997</u>	<u>\$ 220,693</u>
Liabilities and Stockholders' Equity (Deficit)		
Current liabilities:		
Accounts payable	\$ 1,546,388	\$ 1,253,228
Accounts payable, related parties	468,165	336,556
Customer deposits	177,500	60,000
Shareholder advances	1,934,300	558,000
Current portion of long-term debt	338,225	230,756
	<u>4,464,578</u>	<u>2,438,540</u>
Long-term debt	2,292,890	362,186
Commitments and contingencies	-	-
Stockholders' equity (deficit):		
Series A preferred stock, par value of \$.001 per share 75,000,000 shares shares authorized, 0 shares issued and outstanding at December 31, 2013 and December 31, 2012	-	-
Common stock, par value of \$.001 per share 250,000,000 shares authorized, 82,711,524 shares issued and outstanding at December 31, 2013 and 55,955,463 shares issued and outstanding at December 31, 2012	82,712	55,955
Additional paid-in capital	20,321,536	14,956,547
Stock based compensation	5,171,093	3,778,723
Accumulated deficit during the development stage	<u>(27,481,812)</u>	<u>(21,371,258)</u>
	<u>(1,906,471)</u>	<u>(2,580,033)</u>
	<u>\$ 4,850,997</u>	<u>\$ 220,693</u>

See accompanying notes to financial statements.

AMP Holding Inc.
(A Development Stage Company)
Statements of Operations
For the Years Ended December 31, 2013 and 2012
and for the Period From Inception,
February 20, 2007 to December 31, 2013

	Year Ended December 31, 2013	Year Ended December 31, 2012	Since Date of Inception, February 20, 2007 to December 31, 2013
Sales	\$ 177,500	\$ 272,098	\$ 780,340
Expenses:			
Payroll and payroll taxes	1,527,952	1,773,232	8,854,798
Employee benefits	14,464	157,164	667,707
Stock based compensation	1,392,370	338,853	5,188,833
Batteries and motors and supplies	185,784	240,907	2,921,340
Legal and professional	441,439	709,883	2,582,193
Advertising	119,677	429,483	1,386,057
Consulting	1,088,818	59,063	2,192,223
Travel and entertainment	113,774	85,577	598,478
Rent	149,436	148,569	601,434
Insurance	148,684	116,907	534,303
Vehicles, development and testing	211,833	57,786	534,034
Depreciation	319,649	63,629	612,656
Interest and bank fees	258,261	230,887	515,588
Engineering, temporary labor	11,563	4,237	262,849
Facilities, repairs & maintenance	117,770	42,348	322,353
Utilities	160,766	39,614	295,721
Loss on sale of assets	-	14,454	27,544
Other	25,814	31,994	164,041
	<u>6,288,054</u>	<u>4,544,587</u>	<u>28,262,152</u>
Net loss during the development stage	<u>\$ (6,110,554)</u>	<u>\$ (4,272,489)</u>	<u>\$ (27,481,812)</u>
Basic and diluted loss per share	<u>\$ (0.08)</u>	<u>\$ (0.10)</u>	
Weighted average number of common shares outstanding	<u>75,710,613</u>	<u>44,915,220</u>	

See accompanying notes to financial statements.

December 31, 2012	-	-	-	-	-	-	(4,272,489)	(4,272,489)
	55,955,463	\$ 55,955	-	\$ -	\$ 14,956,547	\$ 3,778,723	\$ (21,371,258)	\$ (2,580,033)
Issuance of common stock, and fulfillment of stock subscriptions receivable	21,330,000	21,330	-	-	4,254,270	-	-	4,275,600
Stock options and warrants exercised	18,764	20	-	-	1,143	-	-	1,163
Conversion of convertible note	500,000	500	-	-	99,500	-	-	100,000
Conversion of account payable	4,907,297	4,907	-	-	1,010,076	-	-	1,014,983
Share based compensation for the year ended December 31, 2013	-	-	-	-	-	1,392,370	-	1,392,370
Net loss from operations for the year ended December 31, 2013	-	-	-	-	-	-	(6,110,554)	(6,110,554)
	<u>82,711,524</u>	<u>82,712</u>	<u>-</u>	<u>-</u>	<u>20,321,536</u>	<u>5,171,093</u>	<u>(27,481,812)</u>	<u>(1,906,471)</u>

A vehicle with a fair market value of \$30,400 and cash of \$69,600 was accepted as consideration for issuance of common stock in February 2007.

A vehicle with a fair market value of \$30,884 and cash of \$69,116 was accepted as consideration for issuance of common stock in June 2007.

Consulting services valued at \$50,000 were accepted as consideration for issuance of common stock in October 2008.

Consulting services valued at \$87,000 were accepted as consideration for issuance of common stock in December 2010.

Consulting services valued at \$60,000, \$55,000, and \$203,000 were accepted as consideration for issuance of common stock in March, October, and December 2012, respectively.

Investment Agreement fees valued at \$375,000 were accepted as consideration for issuance of common stock in August 2012.

Legal services valued at \$40,000, \$15,000, and \$25,000 were accepted as consideration for issuance of common stock in September, November, and December 2012, respectively.

Consulting services valued at \$302,500, \$126,000, \$119,075, \$11,750, and \$155,000 were accepted as consideration for issuance of common stock in March, May, June, July, and September 2013, respectively.

Legal services valued at \$40,000, \$15,000, \$5,000, and \$5,000 were accepted as consideration for issuance of common stock in March, June, July, and August 2013, respectively.

Rent expense valued at \$80,190 was accepted as consideration for issuance of common stock in March, June, July, and August 2013, respectively.

See accompanying notes to financial statements.

AMP Holding Inc.
(A Development Stage Company)
Statements of Cash Flows
For the Years Ended December 31, 2013 and 2012
and for the Period From Inception,
February 20, 2007 to December 31, 2013

	Year Ended December 31, 2013	Year Ended December 31, 2012	Since Date of Inception, February 20, 2007 to December 31, 2013
Cash flows from operating activities:			
Net loss during the development stage	\$ (6,110,554)	\$ (4,272,489)	\$ (27,481,812)
Adjustments to reconcile net loss from operations to cash used by operations:			
Depreciation	319,649	63,629	612,656
Loss on sale of assets	-	14,454	27,544
Stock based compensation	1,392,370	338,853	5,188,833
Interest expense on convertible debentures	52,795	106,164	158,959
Amortized discount on convertible debentures	-	91,493	91,493
Legal, consulting and investment services	1,106,328	773,000	2,016,328
Effects of changes in operating assets and liabilities:			
Accounts receivable	-	5,019	-
Inventory	48,252	80,998	7,250
Prepaid expenses and deposits	(30,942)	38,185	(43,967)
Accounts payable	293,160	399,497	2,060,024
Accounts payable, related parties	78,814	124,916	415,370
Customer deposits	117,500	35,000	177,500
Net cash used by operations	<u>(2,732,628)</u>	<u>(2,201,281)</u>	<u>(16,769,822)</u>
Cash flows from investing activities:			
Cash paid in acquisition of Workhorse Custom Chasis, LLC	(2,750,000)		(2,750,000)
Capital expenditures	(63)	(28,753)	(376,713)
Proceeds on sale of assets	-	6,000	38,900
Net cash used by investing activities	<u>(2,750,063)</u>	<u>(22,753)</u>	<u>(3,087,813)</u>
Cash flows from financing activities:			
Proceeds from debentures	-	1,939,250	1,939,250
Proceeds from notes payable	-	-	160,000
Payments on notes payable	-	-	(150,000)
Proceeds from long-term debt	-	-	50,000
Payments on long-term debt	(211,826)	(10,885)	(230,884)
Shareholder advances, net of repayments	1,376,300	246,000	1,934,300
Issuance of common and preferred stock	4,285,418	-	16,161,989
Net cash provided by financing activities	<u>5,449,892</u>	<u>2,174,365</u>	<u>19,864,655</u>
Change in cash and cash equivalents	(32,799)	(49,669)	7,020
Cash at the beginning of the period	39,819	89,488	-
Cash at the end of the period	<u>7,019</u>	<u>39,819</u>	<u>7,020</u>

TABLE OF CONTENTS

Supplemental disclosure of non-cash activities:

Vehicles valued at \$61,284 were contributed as consideration for issuance of common stock in February 2007.

Consulting services valued at \$50,000 were accepted as consideration for issuance of common stock in October 2008.

During March 2010 a note payable of \$10,000 was converted to 29,750 shares of common stock.

A vehicle valued at \$33,427 was acquired through bank financing in September 2010.

Consulting services valued at \$87,000 were accepted as consideration for issuance of common stock in December 2010.

Equipment valued at \$14,937 was acquired through debt financing in December 2011.

Consulting services valued at \$60,000, \$55,000, and \$203,000 were accepted as consideration for issuance of common stock in March, October, and December 2012, respectively.

Detachable warrants associated with convertible debentures valued at \$91,493 were recorded as increases to additional paid-in capital from January to August 2012.

Investment Agreement fees valued at \$375,000 were accepted as consideration for issuance of common stock in August 2012.

Legal services valued at \$40,000, \$15,000, and \$25,000 were accepted as consideration for issuance of common stock in September, November, and December 2012, respectively.

During November 2012 debentures for \$1,939,250 and interest of \$106,164 were converted to 10,227,070 shares of common stock.

During December 2012 accounts payable of \$513,636 were converted to notes payable.

During February 2013 a note payable of \$100,000 was converted to 500,000 shares of common stock.

During March 2013, the Company entered into a note payable in the amount of \$2,250,000 related to the acquisition of Workhorse Custom Chassis, LLC. See note 2 to the financial statements.

Consulting services valued at \$302,500, \$126,000, \$119,075, \$11,750, and \$155,000 were accepted as consideration for issuance of common stock in March, May, June, July, and September 2013, respectively.

Legal services valued at \$40,000, \$15,000, \$5,000, and \$5,000 were accepted as consideration for issuance of common stock in March, June, July, and August 2013, respectively.

Rent expense valued at \$80,190 was accepted as consideration for issuance of common stock in March, June, July, and August 2013, respectively.

See accompanying notes to financial statements.

1. SUMMARY OF SIGNIFICANT ACCOUNTING PRINCIPLES

The following accounting principles and practices are set forth to facilitate the understanding of data presented in the financial statements:

Nature of operations and principles of consolidation

AMP Holding Inc., formerly known as Title Starts Online, Inc. (the Company), incorporated in the State of Nevada in 2007 with \$3,100 of capital from the issuance of common shares to the founding shareholder. On August 11, 2008 the Company received a Notice of Effectiveness from the U.S. Securities and Exchange Commission, and on September 18, 2008, the Company closed a public offering in which it accepted subscriptions for an aggregate of 200,000 shares of its common stock, raising \$50,000 less offering costs of \$46,234. With this limited capital the Company did not commence operations and remained a “shell company” (as defined in Rule 12b-2 under the Securities Exchange Act of 1934, as amended).

On December 28, 2009, the Company entered into and closed a Share Exchange Agreement with the Shareholders of Advanced Mechanical Products, Inc. (n/k/a AMP Electric Vehicles, Inc.) (AMP) pursuant to which the Company acquired 100% of the outstanding securities of AMP in exchange for 14,890,904 shares of the Company’s common stock. Considering that, following the merger, the AMP Shareholders control the majority of the outstanding voting common stock of the Company, and effectively succeeded the Company’s otherwise minimal operations to those that are AMP. AMP is considered the accounting acquirer in this reverse-merger transaction. A reverse-merger transaction is considered and accounted for as a capital transaction in substance; it is equivalent to the issuance of AMP securities for net monetary assets of the Company, which are de minimus, accompanied by a recapitalization. Accordingly, goodwill or other intangible assets have not been recognized in connection with this reverse merger transaction. AMP is the surviving entity and the historical financials following the reverse merger transaction will be those of AMP. The Company was a shell company immediately prior to the acquisition of AMP pursuant to the terms of the Share Exchange Agreement. As a result of such acquisition, the Company operations are now focused on the design, marketing and sale of modified automobiles with an all-electric power train and battery systems. Consequently, we believe that acquisition has caused the Company to cease to be a shell company as it now has operations. The Company formally changed its name to AMP Holding Inc. on May 24, 2010.

Since the acquisition, the Company has devoted the majority of its resources to the development of an all-electric drive system capable of moving heavy large vehicles ranging from full size SUV’s up to and including Medium Duty Commercial trucks. Additionally, in February, 2013 AMP Holding Inc. formed a new wholly owned subsidiary, AMP Trucks Inc., an Indiana corporation. On March 13, 2013 AMP Trucks Inc. closed on the acquisition of an asset purchase of Workhorse Custom Chassis. The assets included in this transaction include: The Workhorse brand, access to the dealer network of 440 dealers nationwide, intellectual property, and all physical assets which include the approximately 250,000 sq. ft. of facilities on 48 acres of land in Union City, Indiana. This acquisition allows AMP Holding Inc. the position as a medium duty OEM capable of producing new chassis with electric, propane, compressed natural gas, and hybrid configurations, as well as gasoline drive systems. Revenues since the inception of the Company, February 20, 2007, through the date of these financial statements have not been significant and consist of customer vehicle conversions and sales of converted experimental vehicles. All significant inter-company transactions have been eliminated in consolidation.

Development stage company

Based on the Company's business plan, it is a development stage company since planned principal operations resulting in revenue have not fully commenced. Accordingly, the Company presents its financial statements in conformity with the accounting principles generally accepted in the United States of America that apply to developing enterprises. As a development stage enterprise, the Company discloses its retained earnings (or deficit accumulated) during the development stage and the cumulative statements of operations and cash flows from commencement of development stage to the current balance sheet date. The development stage began in 2007 when the Company was organized.

Basis of presentation

The financial statements have been prepared on a going concern basis, which contemplates the realization of assets and liquidation of liabilities in the normal course of business. However, the Company has limited revenues and has negative working capital and stockholders' deficits. During 2012 and 2013 the lack of liquidity delayed the Company from paying its employees their full salaries. Employee layoffs have occurred and additional layoffs are considered as a means of conserving cash. These conditions raise substantial doubt about the ability of the Company to continue as a going concern.

In view of these matters, continuation as a going concern is dependent upon the continued operations of the Company, which in turn is dependent upon the Company's ability to meet its financial requirements, raise additional capital, and the success of its future operations. The financial statements do not include any adjustments to the amount and classification of assets and liabilities that may be necessary should the Company not continue as a going concern.

The Company has continued to raise capital. Management believes the proceeds from these offerings, future offerings, and the Company's anticipated revenue provides an opportunity to continue as a going concern. If additional funding is required, the Company plans to obtain working capital from either debt or equity financing from the sale of common, preferred stock, and/or convertible debentures. Obtaining such working capital is not assured.

The preparation of financial statements in conformity with generally accepted accounting principles requires management to make estimates and assumptions that affect the amounts reported in the financial statements and accompanying notes. Actual results could differ from these estimates.

Certain reclassifications were made to the prior year financial statements to conform to the current year presentation. These reclassifications had no effect on previously reported results of operation or stockholders' equity (deficit).

Financial instruments

The carrying amounts of financial instruments including cash, accounts receivable, inventory, cash overdraft, accounts payable and short-term debt approximate fair value because of the relatively short maturity of these instruments.

Inventory

Inventory, stated at cost, includes a vehicle which may be converted for sale.

Property and depreciation

Property and equipment is recorded at cost. Major renewals and improvements are capitalized while replacements, maintenance and repairs, which do not improve or extend the lives of the respective assets, are expensed. When property and equipment is retired or otherwise disposed of, a gain or loss is realized for the difference between the net book value of the asset and the proceeds realized thereon. Depreciation is calculated using the straight-line method, based upon the following estimated useful lives:

- Buildings: 15 – 30 years
- Leasehold improvements: 7 years
- Software: 3 - 6 years
- Equipment: 5 years
- Vehicles and prototypes: 3 - 5 years

Capital stock

On April 22, 2010 the directors of the Company approved a forward stock split of the common stock of the Company on a 14:1 basis. On May 12, 2010 the stockholders of the Company voted to approve the amendment of the certificate of incorporation resulting in a decrease of the number of shares of Common stock. The Company filed a 14c definitive information statement with the Securities and Exchange Commission and mailed the same to its shareholders. Management filed the certificate of amendment decreasing the authorized shares of common stock with the State of Nevada on September 8, 2010.

The capital stock of the Company is as follows:

Preferred Stock - The Company has authorized 75,000,000 shares of preferred stock with a par value of \$.001 per share. These shares may be issued in series with such rights and preferences as may be determined by the Board of Directors. The Series A Stock is convertible, at any time at the option of the holder, into common shares of the Company based on a conversion price of \$0.336 per share. The holders of the Series A Stock are not entitled to convert the Series A Stock and receive shares of common stock such that the number of shares of common stock held by them in the aggregate and their affiliates after such conversion or exercise does not exceed 4.99% of the then issued and outstanding shares of common stock. The Series A Stock has voting rights on an as converted basis, does not pay dividends, and does not provide any liquidation rights.

Common Stock - The Company has authorized 250,000,000 shares of common stock with a par value of \$.001 per share.

Revenue recognition / customer deposits

It is the Company's policy that revenues will be recognized in accordance with SEC Staff Bulletin (SAB) No. 104, "Revenue Recognition". Under SAB 104, product revenues (or service revenues) are recognized when persuasive evidence of an arrangement exists, delivery has occurred (or service has been performed), the sales price is fixed and determinable, and collectability is reasonably assured. Customer deposits include monies from customers to reserve a production slot for conversion of an OEM power train to the AMP all electric power train. The final retail price and delivery date are yet to be determined. Customer deposits are subject to a full refund at the request of the customer.

Advertising

Advertising and public relation costs are charged to operations when incurred. Advertising and public relation expense was approximately \$120,000 and \$429,000 for the years ended December 31, 2013 and 2012, respectively, and \$1,386,000 for the period from inception to December 31, 2013 consisting primarily of consulting fees and travel and related expenses for attendance at car shows and industry expositions.

Income taxes

With the consent of its shareholders, at the date of inception, AMP elected under the Internal Revenue Code to be taxed as an S corporation. Since shareholders of an S corporation are taxed on their proportionate share of the Company's taxable income, an S corporation is generally not subject to either federal or state income taxes at the corporate level. On December 28, 2009 pursuant to the merger transaction the Company revoked its election to be taxed as an S-corporation.

As no taxable income has occurred from the date of this merger to December 31, 2013 cumulative deferred tax assets of approximately \$6,426,000 are fully reserved, and no provision or liability for federal or state income taxes has been included in the financial statements. Net operating losses of approximately \$ 3,600,000 are available for carryover to be used against taxable income generated through 2030, net operating losses of approximately \$6,700,000 are available for carryover to be used against taxable income generated through 2031, and net operating losses of approximately \$3,900,000 are available for carryover to be used against taxable income generated through 2032, and net operating losses of approximately \$4,700,000 are available for carryover to be used against taxable income generated through 2033. The Company had not filed income tax returns during its period as a shell company.

Uncertain tax positions

The Company adopted the provisions of Accounting for Uncertainty in Income Taxes. Those provisions clarify the accounting and recognition for income tax positions taken or expected to be taken in the Company's income tax returns. The Company's income tax filings are subject to audit by various taxing authorities. The years of filings open to these authorities and available for audit are 2010 - 2012. The Company's policy with regard to interest and penalties is to recognize interest through interest expense and penalties through other expense. No interest or penalties with regard to income tax filings were incurred in 2013 or 2012, or since the period of inception, February 20, 2007. In evaluating the Company's tax provisions and accruals, future taxable income, and the reversal of temporary differences, interpretations and tax planning strategies are considered. The Company believes their estimates are appropriate based on current facts and circumstances.

Research and development costs

The Company expenses research and development costs as they are incurred. Research and development expense incurred was approximately \$2,892,000 and \$2,077,000 for the years ended December 31, 2013, and 2012, respectively, and \$14,583,000 for the period from inception to December 31, 2013, consisting of consulting, payroll, payroll taxes, engineering temporaries, purchased supplies, legal fees, parts and small tools.

Basic and diluted loss per share

Basic loss per share is computed by dividing net loss available to common shareholders (numerator) by the weighted average number of shares outstanding (denominator) during the period. For all periods, all of the Company's common stock equivalents were excluded from the calculation of diluted loss per common share because they were anti-dilutive, due to the Company's net losses.

Stock based compensation

The Company accounts for its stock based compensation in accordance with "Share-Based Payments" (codified in FASB ASC Topic 718 and 505). The Company recognizes in its statement of operations the grant-date fair value of stock options and warrants issued to employees and non-employees. The fair value is estimated on the date of grant using a lattice-based valuation model that uses assumptions concerning expected volatility, expected term, and the expected risk-free rate of return. For the awards granted, the expected volatility was estimated by management as 50% based on a range of forecasted results. The expected term of the awards granted was assumed to be the contract life of the option or warrant (one, two, three, five or ten years as determined in the specific arrangement). The risk-free rate of return was based on market yields in effect on the date of each grant for United States Treasury debt securities with a maturity equal to the expected term of the award.

Related party transactions

Certain stockholders and stockholder family members have advanced funds or performed services for the Company. These services are believed to be at market rates for similar services from non-related parties. Related party accounts payable are segregated in the balance sheet. An experimental vehicle was sold to a stockholder in 2012 for \$50,000 and in 2010 for \$25,000, which also approximates the selling price to non-related parties.

Subsequent events

On December 11, 2013, the Company entered into a Promissory Note with JMJ Financial in the principal amount up to \$335,000 of which only \$80,000 was funded. On March 7, 2014, the Company paid the outstanding balance owed under the Note and, as a result, has no further obligations to JMJ under the Note.

On March 18, 2014, the Company entered into a Subscription Agreement with Joseph T. Lukens (“Lukens”), an existing shareholder and an accredited investor, whereby Lukens agreed to acquire 30,000,000 shares of common stock and Common Stock Purchase Warrants to acquire 15,000,000 shares of common stock in consideration of \$3,000,000.

2. ACQUISITION

On March 13, 2013 the Company acquired the operating assets of Workhorse Custom Chassis, LLC, an unrelated company located in Union City, Indiana. The following summarizes the consideration paid, and the components of the purchase price and the related allocation of assets acquired and liabilities assumed.

<u>Consideration</u>	
Cash at closing	2,750,000
Secured debenture	2,250,000
	<u>5,000,000</u>
<u>Assets acquired</u>	
Inventory	400,000
Equipment	500,000
Land	300,000
Buildings	3,800,000
	<u>5,000,000</u>

Valuation methods used for the identifiable assets acquired in the acquisition make use of fair value measurements based on unobservable inputs and reliance on management’s assumptions that similar market participants would use in pricing the assets. As such, the fair value measurements represent a Level 3 input

3. LONG-TERM DEBT

	<u>December 31,</u> 2013	<u>December 31,</u> 2012
Long-term debt consists of the following:		
Secured debenture payable to Workhorse Custom Chassis, LLC, due March 2016 plus interest at 10%. The debenture is secured by the real estate and related assets of the plant located in Union City, Indiana with a net book value of \$4,335,000 at December 31, 2013	2,250,000	-
Note payable, Bank due in monthly installments of \$635 including interest at 5.04% with the final payment due August 2015. The note is secured by equipment with a net book value of \$11,147 at December 31, 2013	11,928	18,761
Note payable, vendor due in monthly installments of \$439 including interest at 8.00% with the final payment due December 2014. The note is secured by equipment with a net book value of \$8,775 at December 31, 2013	5,051	10,545
Note payable to the City of Loveland, due in annual installments of \$10,241 including interest with the final payment due October 2016. Interest rate amended to 8.00%. The note is unsecured and contains restrictions on the use of proceeds.	50,000	50,000
Note payable, vendor due in monthly installments of \$5,000 for the first half of 2013, escalating to final payment of \$43,736 in March 2014. Note is noninterest bearing and is unsecured.	123,736	281,236
Note payable, vendor due in monthly installments of \$2,000 plus interest at 4% for the first half of 2013, escalating to final payment of \$18,461 plus interest at 4% in December 2014. Note is unsecured.	<u>190,400</u>	<u>232,400</u>
	2,631,115	592,942
Less current portion	<u>338,225</u>	<u>230,756</u>
Long term debt	<u><u>2,292,890</u></u>	<u><u>362,186</u></u>

Aggregate maturities of long-term debt are as follows:

2014	338,225
2015	32,890
2016	<u>2,260,000</u>
	<u>2,631,115</u>

The note payable to the City of Loveland contains job creation incentives whereby each annual payment may be forgiven by the City upon the Company meeting minimum job creation benchmarks. This loan agreement amended the incentives to 30 full time employees within the City of Loveland with payroll totaling \$135,000 by July 31, 2013 and 40 employees with payroll totaling \$175,000 by July 31, 2014, continuing with an average of 40 employees with payroll totaling \$175,000 thereafter. The proceeds from this loan were to be used for qualified disbursements only, and the Company has been notified it did not meet the requirements for qualified disbursements and for forgiveness of the 2012 principal and interest payment, which is now past due. In 2013 the Company has an accrual on the books for \$22,900.

4. CONVERTIBLE DEBENTURES

From January 6, 2012 through August 3, 2012, the Company entered into Securities Purchase Agreements and Security Agreements with several accredited investors (the "2012 Investors") providing for the sale by the Company to the 2012 Investors of Secured Convertible Debentures in the aggregate amount of \$1,939,250 (the "2012 Notes"). The Company received the proceeds in connection with these financings between January 6, 2012 and August 3, 2012. Further a shareholder, director and officer converted secured and unsecured loans provided to the Company from September 30, 2011 to June 5, 2012 in the aggregate amount of \$389,250 into the 2012 Notes and 2012 Warrants. The 2012 Notes were to mature one year from their respective effective dates (the "Maturity Dates") and interest associated with the 2012 Notes was 10% per annum, payable on the Maturity Dates. In November 2012, the Company entered into a Note and Warrant Amendment and Conversion Agreement whereby the holders and the 2012 Investors converted all principal and interest under the 2012 Notes into 10,227,070 shares of common stock. Further, the exercise price of the 2012 Warrants was reduced to \$0.25 per share.

In addition to the 2012 Notes, the 2012 Investors also received common stock purchase warrants (the “2012 Warrants”) to acquire 1,939,250 shares of common stock of the Company. The 2012 Warrants are exercisable for three years at an exercise price of \$0.50 per share, reduced to \$0.25 per share as noted above. The value of the detachable 2012 Warrants was determined using a lattice-based valuation model that used an expected volatility, estimated by management as 50% based on a range of forecasted results, and an expected risk-free rate of return, based on market yields in effect on the grant dates for United States Treasury debt securities with a three year maturity. The \$91,493 value of the detachable 2012 Warrants was recorded as an increase in additional paid-in capital and a discount against the 2012 Notes. The discount on the 2012 notes was amortized as interest expense during the period that the 2012 Notes were outstanding. Amortization charged to the Statement of Operations is \$91,493 for the year ended December 31, 2013.

The 2012 Notes and the 2012 Warrants carry standard anti-dilution provisions but in no event may the conversion price be reduced below \$0.25. Further, the 2012 Investors will have the right to participate in the next financing on a pro-rata basis up to \$1,000,000.

5. SHAREHOLDER AND RELATED PARTY ADVANCES

Investor advances are as follows:

2013	2012	Rate	Date	Expire	Note
43,000	43,000	3%	11/30/2009	3/31/2012	1
15,000	15,000	10%	10/5/2012	10/5/2013	1
100,000	100,000	10%	10/16/2012	10/16/2013	1
100,000	100,000	10%	10/16/2012	10/16/2013	1
50,000	50,000	10%	10/19/2012	10/19/2013	1
50,000	50,000	10%	11/2/2012	11/2/2013	1
50,000	50,000	10%	11/8/2012	11/8/2013	1
100,000	100,000	10%	12/6/2012	12/6/2013	1
50,000	50,000	10%	12/19/2012	12/19/2013	1
3,200		10%	10/10/2013	10/10/2014	
2,500		10%	11/5/2013	11/5/2014	
200,000		10%	11/12/2013	11/12/2014	
50,000		10%	12/2/2013	12/2/2014	
50,000		10%	12/30/2013	12/30/2014	
80,000			12/11/2013		2
990,600			Various 2013		3
<u>1,934,300</u>	<u>558,000</u>				

- 1 The term of the advance has expired but the shareholders have no demanded repayment. The Company is negotiating to have the advances converted into equity during the first quarter of 2014.
- 2 Paid on 3/8/2014, see subsequent events note.
- 3 Various non-interest bearing shareholders' deposits. Being converted into equity first quarter 2014.

6. LEASE OBLIGATIONS

On October 1, 2011 the Company began leasing operating facilities under an agreement expiring on September 30, 2018. Future minimum monthly lease payments under the agreement are currently \$12,231 and increase 3% in October of each year. Prepaid expenses and deposits include a security deposit equal to \$12,275. Aggregate maturities of lease obligations are as follows:

2014	152,312
2015	156,881
2016	161,588
2017	166,435
2018	127,614
	<u>764,830</u>

The Company also leased office space for approximately \$1,000 per month on a month to month agreement through May 2012 and two apartments for approximately \$2,200 per month on month to month agreements through January 2012. Total rent expense under these operating type leases for the years ended December 31, 2013 and 2012 was \$ 149,436 and \$ 148,569, respectively, and \$ 601,434 for the period from inception to December 31, 2013.

7. STOCK BASED COMPENSATION

Options to directors, officers and employees

The Company maintains, as adopted by the board of directors, the 2013 Incentive Stock Plan, the 2012 Incentive Stock Plan, the 2011 Incentive Stock Plan and the 2010 Stock Incentive Plan (the plans) providing for the issuance of up to 11,000,000 options to employees, officers, directors or consultants of the Company. Incentive stock options granted under the plans may only be granted with an exercise price of not less than fair market value of the Company's common stock on the date of grant (110% of fair market value for incentive stock options granted to principal stockholders). Non-qualified stock options granted under the plans may only be granted with an exercise price of not less than 85% of the fair market value of the Company's common stock on the date of grant. Awards under the plans may be either vested or unvested options. The unvested options vest ratably over eight quarters for options with a five or three year term and after one year for options with a two year term.

In addition to the plans, the Company has granted, on various dates, stock options to directors, officers and employees to purchase common stock of the Company. The terms, exercise prices and vesting of these awards vary.

The following table summarizes option activity for directors, officers and employees:

	Number of Shares	Weighted Average Exercise Price per Share	Weighted Average Grant Date Fair Value per Share	Weighted Average Remaining Exercise Term in Months
Outstanding at December 31, 2010	4,940,000	\$ 0.56	\$ 0.33	77
Exercisable at December 31, 2010	1,854,625	\$ 0.53	\$ 0.32	75
Granted	3,425,000	0.63	0.28	54
Exercised	(29,750)	0.41	0.26	40
Forfeited	-	-	-	-
Expired	-	-	-	-
Outstanding at December 31, 2011	8,335,250	\$ 0.59	\$ 0.31	58
Exercisable at December 31, 2011	4,588,875	\$ 0.57	\$ 0.31	60
Granted	2,025,000	0.13	0.05	40
Exercised	-	-	-	-
Forfeited	(1,315,375)	0.61	0.27	40
Expired	(1,314,375)	0.55	0.29	51
Outstanding at December 31, 2012	7,730,500	\$ 0.48	\$ 0.25	44
Exercisable at December 31, 2012	6,080,000	\$ 0.54	\$ 0.29	46
Granted	2,100,000	0.29	0.12	45
Exercised	(21,126)	0.11	0.04	29
Forfeited	-	-	-	-
Expired	(505,000)	0.70	0.20	-
Outstanding at December 31, 2013	9,304,374	\$ 0.44	\$ 0.23	39
Exercisable at December 31, 2013	6,670,937	\$ 0.51	\$ 0.27	38

The Company recorded \$421,281, \$325,673, \$855,246, and \$2,208,141 compensation expense for stock options to directors, officers and employees for the years ended December 31, 2013, 2012, 2011 and the period from inception (February 20, 2007) to December 31, 2013, respectively. As of December 31, 2013, unrecognized compensation expense of \$541,832 is related to non-vested options granted to directors, officers and employees which is anticipated to be recognized over the next 35 months, commensurate with the vesting schedules.

Options to consultants

The Company has also granted, on various dates, stock options to purchase common stock of the Company to consultants for services previously provided to the Company. The terms, exercise prices and vesting of these awards vary.

The following table summarizes option activity for consultants:

	Number of Shares	Weighted Average Exercise Price per Share	Weighted Average Grant Date Fair Value per Share	Weighted Average Remaining Exercise Term in Months
Outstanding at December 31, 2010	810,000	\$ 0.67	\$ 0.23	32
Exercisable at December 31, 2010	380,000	\$ 0.63	\$ 0.22	31
Granted	70,000	0.59	0.18	31
Exercised	-	-	-	-
Forfeited	-	-	-	-
Expired	-	-	-	-
Outstanding at December 31, 2011	880,000	\$ 0.66	\$ 0.23	20
Exercisable at December 31, 2011	755,000	\$ 0.64	\$ 0.22	20
Granted	150,000	0.11	0.04	36
Exercised	-	-	-	-
Forfeited	(30,000)	0.76	0.25	9
Expired	(340,000)	0.83	0.28	8
Outstanding at December 31, 2012	660,000	\$ 0.45	\$ 0.15	14
Exercisable at December 31, 2012	561,000	\$ 0.50	\$ 0.17	10
Granted	400,000	0.21	0.10	57
Exercised	-	-	-	-
Forfeited	-	-	-	-
Expired	(810,000)	0.67	0.23	-
Outstanding at December 31, 2013	250,000	\$ 0.35	\$ 0.13	23
Exercisable at December 31, 2013	628,125	\$ 0.39	\$ 0.15	17

The Company recorded \$68,747, \$(70,171), \$83,265 and \$164,741 compensation expense for stock options to consultants for the years ended December 31, 2013, 2012, 2011 and the period from inception (February 20, 2007) to December 31, 2013, respectively. As of December 31, 2013, unrecognized compensation expense of \$71,017 is related to non-vested options granted to consultants which is anticipated to be recognized over the next 35 months, commensurate with the vesting schedules.

Warrants to accredited investors

From December 2010 through December 2011, common stock sold by the Company included common stock purchase warrants to acquire shares of common stock of the Company. For each ten shares sold, each investor received a warrant to purchase five shares of common stock for a period of two years at an exercise price of \$0.80 per share. In November 2012, the purchase warrants were modified to change the exercise period from two years to three years. The \$112 cost of this modification is included in stock based compensation expense for the year ended December 31, 2013.

From January 2012 through August 2012, the 2012 Investors received 2012 Warrants to acquire common stock of the Company. The 2012 Warrants are exercisable for three years at an exercise price of \$0.50. In November 2012, the Company entered into a Note and Warrant Amendment and Conversion Agreement whereby the holders and the 2012 Investors converted all principal and interest under the 2012 Notes into shares of common stock. Further, the exercise price of the 2012 Warrants was reduced to \$0.25 per share. The \$20,795 cost of the reduction in the exercise price for accredited investors is included in stock based compensation expense for the year ended December 31, 2013.

The above securities were offered and sold to the investors in private placement transactions made in reliance upon exemptions from registration pursuant to Section 4(2) under the Securities Act of 1933 (the "Securities Act") and/or Rule 506 promulgated under the Securities Act. The investors are accredited investors as defined in Rule 501 of Regulation D promulgated under the Securities Act.

The following table summarizes warrant activity for accredited investors:

	Number of Shares	Weighted Average Exercise Price per Share	Weighted Average Grant Date Fair Value per Share	Weighted Average Remaining Exercise Term in Months
Outstanding at December 31, 2010	785,001	\$ 0.80	\$ 0.11	24
Exercisable at December 31, 2010	785,001	\$ 0.80	\$ 0.11	24
Granted	4,956,224	0.80	0.11	24
Exercised	-	-	-	-
Forfeited	-	-	-	-
Expired	-	-	-	-
Outstanding at December 31, 2011	5,741,225	\$ 0.80	\$ 0.11	17
Exercisable at December 31, 2011	5,741,225	\$ 0.80	\$ 0.11	17
Granted	1,450,000	0.50	0.06	36
Modified warrants prior to modifications	(7,191,225)	0.74	0.10	10
Modified warrants after modifications	7,191,225	0.69	0.10	20
Exercised	-	-	-	-
Forfeited	-	-	-	-
Expired	-	-	-	-
Outstanding at December 31, 2012	7,191,225	\$ 0.69	\$ 0.10	19
Exercisable at December 31, 2012	7,191,225	\$ 0.69	\$ 0.10	19
Granted	10,954,063	0.40	0.05	28
Exercised	-	-	-	-
Forfeited	-	-	-	-
Expired	(1,901,666)	0.76	0.13	-
Outstanding at December 31, 2013	16,243,622	\$ 0.52	\$ 0.07	22
Exercisable at December 31, 2013	16,243,622	\$ 0.52	\$ 0.07	22

The Company recorded \$902,342, \$20,907, \$546,824, and \$1,556,423 compensation expense for stock warrants to accredited investors for the years ended December 31, 2013, 2012, 2011 and the period from inception (February 20, 2007) to December 31, 2013, respectively. There is no unrecognized compensation expense for these warrants because they are fully vested at date of grant.

Warrants to placement agent and consultants

Through December 2011, the Company compensated the placement agent for assisting in the sale of the Company's securities by paying the placement agent commissions and issuing the placement agent common stock purchase warrants to purchase shares of the Company's common stock. The warrants have a five year term and various exercise prices.

The Company has also granted, on various dates, stock warrants to purchase common stock of the Company to consultants for services previously provided to the Company. The terms, exercise prices and vesting of these awards vary.

The following table summarizes warrant activity for the placement agent and consultants:

	Number of Shares	Weighted Average Exercise Price per Share	Weighted Average Grant Date Fair Value per Share	Weighted Average Remaining Exercise Term in Months
Outstanding at December 31, 2010	3,717,984	\$ 0.60	\$ 0.21	52
Exercisable at December 31, 2010	2,617,984	\$ 0.61	\$ 0.19	51
Granted	887,910	0.60	0.27	60
Exercised	(44,638)	0.40	0.18	39
Forfeited	-	-	-	-
Expired	-	-	-	-
Outstanding at December 31, 2011	4,561,256	\$ 0.60	\$ 0.22	43
Exercisable at December 31, 2011	4,081,256	\$ 0.59	\$ 0.21	42
Granted	28,334	0.60	0.24	60
Exercised	-	-	-	-
Forfeited	-	-	-	-
Expired	-	-	-	-
Outstanding at December 31, 2012	4,589,590	\$ 0.60	\$ 0.22	31
Exercisable at December 31, 2012	4,339,590	\$ 0.59	\$ 0.21	31
Granted	-	-	-	-
Exercised	-	-	-	-
Forfeited	-	-	-	-
Expired	-	-	-	-
Outstanding at December 31, 2013	4,589,590	\$ 0.60	\$ 0.22	22
Exercisable at December 31, 2013	4,339,590	\$ 0.60	\$ 0.22	22

The Company recorded \$0, \$64,936, \$373,876 and \$936,340 compensation expense for stock warrants to the placement agent and consultants for the years ended December 31, 2013, 2012, 2011 and the period from inception (February 20, 2007) to December 31, 2013, respectively. As of December 31, 2013, unrecognized compensation expense of \$82,500 is related to non-vested warrants granted to consultants which is anticipated to be recognized over the next 32 months, commensurate with the vesting schedules. There is no unrecognized compensation expense for the placement agent warrants because they are fully vested at date of grant.

Warrants to directors and officers

In December 2010 and May 2011, the Company issued to certain directors and officers common stock purchase warrants to acquire shares of common stock at an exercise price of \$2.00 per share for a period of five years. In November 2011, under the terms of a Promissory Note issued to a director and officer, common stock purchase warrants were issued to acquire 100,000 shares of common stock at an exercise price of \$0.50 per share for a period of one year. In May 2012, a director and officer received 100,000 2012 Warrants to acquire common stock of the Company at an exercise price of \$0.50 for a period of three years. In June 2012, a director and officer converted secured and unsecured loans provided to the Company from September 2011 to June 2012 in the aggregate amount of \$389,250 into the 2012 Notes and 2012 Warrants. In November 2012, the Company entered into a Note and Warrant Amendment and Conversion Agreement whereby the holders and the 2012 Investors converted all principal and interest under the 2012 Notes into shares of common stock. Further, the exercise price of the 2012 Warrants was reduced to \$0.25 per share. The \$7,388 cost of the reduction in the exercise price for officers and directors is included in stock based compensation expense for the year ended December 31, 2013.

The following table summarizes warrant activity for directors and officers:

	Number of Shares	Weighted Average Exercise Price per Share	Weighted Average Grant Date Fair Value per Share	Weighted Average Remaining Exercise Term in Months
Outstanding at December 31, 2010	1,400,000	\$ 2.00	\$ 0.13	59
Exercisable at December 31, 2010	1,400,000	\$ 2.00	\$ 0.13	59
Granted	1,600,000	1.91	0.09	57
Exercised	-	-	-	-
Forfeited	-	-	-	-
Expired	-	-	-	-
Outstanding at December 31, 2011	3,000,000	\$ 1.95	\$ 0.11	49
Exercisable at December 31, 2011	3,000,000	\$ 1.95	\$ 0.11	49
Granted	489,250	0.50	0.01	36
Modified warrants prior to modifications	(489,250)	0.50	0.01	31
Modified warrants after modifications	489,250	0.25	0.01	31
Exercised	-	-	-	-
Forfeited	-	-	-	-
Expired	(100,000)	0.50	0.10	-
Outstanding at December 31, 2012	3,389,250	\$ 1.75	\$ 0.09	37
Exercisable at December 31, 2012	3,389,250	\$ 1.75	\$ 0.09	37
Granted	-	-	-	-
Exercised	-	-	-	-
Forfeited	-	-	-	-
Expired	(100,000)	0.50	0.10	-
Outstanding at December 31, 2013	3,289,250	\$ 1.75	\$ 0.09	28
Exercisable at December 31, 2013	3,289,250	\$ 1.75	\$ 0.09	28

The Company recorded \$0, \$(2,492), \$143,680 and \$323,188 compensation expense for stock warrants to directors and officers for the years ended December 31, 2013, 2012, 2011 and the period from inception (February 20, 2007) to December 31, 2013, respectively. There is no unrecognized compensation expense for these warrants because they are fully vested at date of grant.

8. RECENT PRONOUNCEMENTS

In February 2013, the FASB issues ASU 2013-02, Comprehensive Income (Topic 220) – Reporting of Amounts Reclassified out of Accumulated Other Comprehensive Income. The amendments do not change the current requirements for reporting net income or other comprehensive income in financial statements. These amendments require an entity to provide information about the amounts reclassified out of accumulated other comprehensive income by component. In addition, an entity is required to present, either on the face of the statement where net income is presented or in the notes, significant amounts reclassified out of accumulated other comprehensive income by the respective line items of net income but only if the amount reclassified is required under U.S. GAAP to be reclassified to net income in its entirety in the same reporting period. For other amounts that are not required under U.S. GAAP to be reclassified in their entirety to net income, an entity is required to cross-reference to other disclosures required under U.S. GAAP that provide additional details about those amounts. For public entities, the amendments are effective prospectively for fiscal years, and interim periods within those years, beginning after December 15, 2012. Early adoption is permitted. We do not anticipate any material impact from this Update.

In July 2013, the FASB issued ASU No. 2013-11, Presentation of an Unrecognized Tax Benefit When a Net Operating Loss Carryforward, a Similar Tax Loss, or a Tax Credit Carryforward Exists, which amends ASC 740, Income Taxes. The amendments provide guidance on the financial statement presentation of an unrecognized tax benefit, as either a reduction of a deferred tax asset or as a liability, when a net operating loss carryforward, similar tax loss, or a tax credit carryforward exists. The amendments are effective for fiscal years, and interim periods within those years, beginning after December 15, 2013 and may be applied on either a prospective or retrospective basis. We do not expect the adoption of these provisions to have a significant impact on the Company's consolidated financial statements.

Units
Each Unit Consisting of One Share of Common Stock and
One-Half (0.5) Series A Warrant to Purchase One-Half (0.5) Share of Common Stock



PROSPECTUS

, 2015

Dawson James Securities, Inc.

You should rely only on the information contained in this prospectus. No dealer, salesperson or other person is authorized to give information that is not contained in this prospectus. This prospectus is not an offer to sell nor is it seeking an offer to buy these securities in any jurisdiction where the offer or sale is not permitted. The information in this prospectus is accurate only as of the date of this prospectus, regardless of the time of delivery of this prospectus or of any sale of these securities.

Through and including _____, 2014 (the 25th day after the commencement of this offering), all dealers effecting transactions in these securities, whether or not participating in this offering, may be required to deliver a prospectus. This is in addition to a dealer's obligation to deliver a prospectus when acting as underwriters and with respect to their unsold allotments or subscriptions.

PART II — INFORMATION NOT REQUIRED IN PROSPECTUS**Item 13. Other Expenses of Issuance and Distribution**

The following table sets forth all expenses, other than the underwriting discounts and commissions, payable by the registrant in connection with the sale of the common stock being registered. All the amounts shown are estimates except the SEC registration fee and the FINRA filing fee.

	Amount to be paid
SEC registration fee	\$ 1,865.01
FINRA filing fee	\$ *
The NYSE MKT or NASDAQ Capital Market initial listing fee	\$ *
Blue sky qualification fees and expenses	\$ *
Transfer agent and registrar fees	\$ *
Accounting fees and expenses	\$ *
Legal fees and expenses	\$ *
Printing and engraving expenses	\$ *
Miscellaneous	\$ *
Total	\$ *

* To be included in a subsequent amendment.

Item 14. Indemnification of Directors and Officers

Section 78.7502 of the Nevada Revised Statutes authorizes a corporation's board of directors to grant, and authorizes a court to award, indemnity to officers, directors and other corporate agents.

As permitted by Section 78.7502 of the Nevada Revised Statutes, the Registrant's articles of incorporation, as amended, includes provisions that limit or eliminate the personal liability of its directors and officers for monetary damages for breach of their fiduciary duty as directors and officers.

In addition, as permitted by Sections 78.7502, 78.751 and 78.752 of the Nevada Revised Statutes, the articles of incorporation and bylaws of the Registrant provide that:

- The Registrant shall indemnify its directors and officers for serving the Registrant in those capacities or for serving other business enterprises at the Registrant's request, to the fullest extent permitted by Nevada law. Nevada law provides that a corporation may indemnify such person if such person did not otherwise violate Nevada law and acted in good faith and in a manner such person reasonably believed to be in or not opposed to the best interests of the Registrant and, with respect to any criminal proceeding, had no reasonable cause to believe such person's conduct was unlawful.
- The Registrant may, in its discretion, indemnify employees and agents in those circumstances where indemnification is permitted by applicable law.
- The Registrant is required to advance expenses, as incurred, to its directors and officers in connection with defending a proceeding, except that such director or officer shall undertake to repay any such advance to the extent that it is ultimately determined that such person is not entitled to indemnification.
- The Registrant will not be obligated pursuant to the amended and restated bylaws to indemnify a person with respect to proceedings initiated by that person, except with respect to proceedings authorized by the Registrant's board of directors or brought to enforce a right to indemnification.

We shall not indemnify a director or officer for any claim, issue or matter as to which the director or officer has been adjudged by a court of competent jurisdiction, after exhaustion of all appeals therefrom, to be liable to the us for any amounts paid in settlement to us, unless and only to the extent that the court in which the proceeding was brought or other court of competent jurisdiction determines upon application that in view of all the circumstances of the case, the director or officer is fairly and reasonably entitled to indemnity for such amounts as the court deems proper. Indemnification may not be made to or on behalf of a director or officer if a final adjudication establishes that his or her acts or omissions involved intentional misconduct, fraud or a knowing violation of law and was material to the cause of action. No director or officer may be indemnified for expenses incurred in defending any threatened, pending, or completed action, suit or proceeding (including without limitation, an action, suit or proceeding by or in the right of the corporation), whether civil, criminal, administrative or investigative, that such director or officer incurred in his or her capacity as a stockholder.

We may purchase and maintain insurance or make other financial arrangements on behalf of any person for any liability asserted against him or her and liability and expenses incurred by him or her in his or her capacity as a director, officer, employee, member, managing member or agent, or arising out of his or her status as such, whether or not the corporation has the authority to indemnify him or her against such liability and expenses.

Item 15. Recent Sales of Unregistered Securities

The following sets forth information regarding all unregistered securities since November 20, 2011:

From January 6, 2012 through August 3, 2012, the Company entered into Securities Purchase Agreements and Security Agreements with several accredited investors (the "2012 Investors") providing for the sale by the Company to the 2012 Investors of Secured Convertible Debentures in the aggregate amount of \$1,939,250 (the "2012 Notes"). In addition to the 2012 Notes, the 2012 Investors also received common stock purchase warrants (the "2012 Warrants") to acquire 1,939,250 shares of common stock of the Company. The 2012 Warrants were exercisable for three years at an exercise price of \$0.50. The Company received the proceeds in connection with these financings between January 6, 2012 and August 3, 2012. Further, a shareholder, director and officer, converted secured and unsecured loans provided to the Company from September 30, 2011 to June 5, 2012 in the aggregate amount of \$389,250 into the 2012 Notes and 2012 Warrants. In November 2012, the Company entered into a Note and Warrant Amendment and Conversion Agreement whereby the holders and the 2012 Investors converted all principal and interest under the 2012 Notes into 10,227,070 shares of common stock. Further, the exercise price of the 2012 Warrants was reduced to \$0.25 per share.

In March 2012 the Company settled outstanding invoices for consulting services totaling \$60,000 by issuing 177,515 shares of common stock.

On August 10, 2012, Company granted James Taylor options to purchase 300,000 shares of the Company's common stock at an exercise price of \$0.15 per share. The options expire after five years with 100,000 options vesting immediately and 100,000 options vesting each of the following two years on the anniversary date.

On August 20, 2012, the Company entered into an Investment Agreement ("Investment Agreement") with Kodiak Capital Group, LLC ("Kodiak"). Pursuant to the Investment Agreement, Kodiak has committed to purchase up to \$7,500,000 of the Company's common stock during the period commencing upon the effective date of a registration statement registering the shares of common stock underlying the equity line (the "Equity Line") and continuing for 24 months. The aggregate number of shares issuable by the Company and purchasable by Kodiak under the Investment Agreement will be determined by the purchase prices for the common stock, as determined under the terms of the Investment Agreement. Upon execution of the Investment Agreement, the Company issued to Kodiak 1,875,000 commitment shares of newly-issued common stock. The Company has elected to not pursue the Equity Line with Kodiak.

On August 24, 2012, Martin J. Rucidlo was engaged by the Company to serve as the President of the Company. On August 24, 2012, Mr. Rucidlo entered into a letter agreement with the Company pursuant to which he was appointed as the President of the Company in consideration of an annual salary of \$125,000. As additional compensation, the Company granted Mr. Rucidlo options to purchase 300,000 shares of the Company's common stock at an exercise price of \$0.21 per share. The options will expire three years from the vesting period with 90,000 options vesting upon the signing of the Agreement and 105,000 options vesting each of the following two years on the anniversary date of the Agreement for a total of 300,000 shares.

In September 2012, the Company settled outstanding invoices for legal services totaling \$40,000 by issuing 400,000 shares of common stock.

In October 2012, the Company settled outstanding invoices for consulting services totaling \$55,000 by issuing 500,000 shares of common stock.

Between October 16, 2012 and December 19, 2012, shareholders and related parties advanced \$500,000 to the Company for working capital needs. In consideration of such advances, the Company issued promissory notes with interest at 10% per annum due October 16, 2013. The notes were unsecured and require the Company to designate part of the proceeds of financing in excess of \$2,000,000 to be used for repayment of these notes. The Company was in violation of this covenant in 2013 as financing in excess of \$2,000,000 has occurred and repayment of these notes has not occurred.

In November 2012, the Company settled outstanding invoices for legal services totaling \$15,000 by issuing 157,895 shares of common stock.

In December 2012, the Company settled outstanding invoices for consulting services totaling \$175,000 by issuing 3,500,000 shares of common stock.

In December 2012, the Company entered into placement agent agreements with Northeast Securities Inc. and Midtown Partners & Company, LLC. The Company issued 25,000 shares of common stock to Northeast Securities Inc. and 150,000 shares of common stock to Midtown Partners & Co., LLC, with a cost basis of \$0.16 per share, as up-front compensation under the agreements.

On December 4, 2012, the Company granted stock options to acquire 1,575,000 shares of common stock to officers, employees and consultants under the 2012 Incentive Stock Plan at an exercise price of \$0.11 per share for a period of three years vesting 34% on December 31, 2013, 8.35% at the end of each quarter thereafter for eight quarters, ending December 31, 2014.

In December 2012, the Company settled outstanding invoices for legal services totaling \$25,000 by issuing 208,333 shares of common stock.

TABLE OF CONTENTS

On January 29, 2013, the Company entered into a subscription agreement with an accredited investor pursuant to which the investor purchased 500,000 shares of the Company's common stock at a cost basis of \$0.20 per share, for a purchase price of \$100,000, together with a common stock purchase warrant to acquire 250,000 shares of common stock at \$0.40 per share for a period of three years.

In addition, on January 29, 2013, an accredited investor loaned the Company \$100,000. In consideration of such loan, the Company issued a Promissory Note which bears interest at 10% per annum and matures on January 29, 2014. The Note can be prepaid in whole or in part at any time without the consent of the holder provided that the Company shall pay all accrued interest on the principal so prepaid to date of such prepayment. On February 21, 2013, the Company and the holder entered into a Conversion Agreement pursuant to which the parties converted the Note of January 29, 2013 into 500,000 shares of common stock of the Company at a cost basis of \$0.20 per share and a common stock purchase warrant to acquire 250,000 shares of common stock of the Company. The warrant is exercisable for three years at an exercise price of \$0.40.

On March 13, 2013, the Company entered into a subscription agreement with various accredited investors pursuant to which the investors purchased 17,925,000 shares of the Company's common stock at a cost basis of \$0.20 per share, for a purchase price of \$3,585,000, together with common stock purchase warrants to acquire 8,962,500 shares of common stock at \$0.40 per share for a period of three years.

On March 13, 2013 the Company agreed to compensate a business development consultant for work performed relating to the Workhorse Custom Chassis purchase by issuing 1,125,000 shares of common stock at a cost basis of \$0.20 per share and a cash payment of \$25,000. Additionally, on March 13, 2013 the Company agreed to compensate a consultant that performed due diligence work related to the Workhorse Custom Chassis purchase by issuing 50,000 shares of common stock at a cost basis of \$0.23 per share.

On March 15, 2013 the Company granted 1,100,000 common stock options, from the 2013 Incentive Stock Plan, to certain executives and employees of the Company for work on the Workhorse Custom Chassis purchase. The options are exercisable at \$0.29 per share for a period of five years and vest 20% on March 15, 2014, 20% on March 15, 2015, 20% on March 15, 2016 and 40% on March 15, 2017.

On March 19, 2013 the Company agreed to compensate a new Advisory Board Member by issuing 300,000 shares of common stock at a cost basis of \$0.25 per share and a common stock option to acquire 50,000 shares at an exercise price of \$0.25 per share for a period of five years, with 16,666 vesting on the first anniversary date and 16,667 vesting on each of the next two anniversary dates.

On March 21, 2013, the Company settled outstanding invoices for legal services totaling \$40,000 by issuing 266,667 shares of common stock at a cost basis of \$0.15 per share.

On April 15, 2013 the Company agreed to compensate a sales and marketing consultant for services performed by issuing 25,000 shares of common stock per month. The agreement is for a term of six months and may be terminated by either party with 30 days written notice. The Company also agreed to compensate the consultant based on performance in securing sales for the Company by issuing up to 500,000 shares of restricted common stock in the form of shares or options at the discretion of the consultant. On June 30, 2013, as payment for services performed from April 15 to June 30, 2013, 62,500 shares were issued at a cost basis of \$0.3724 per share. Additionally, on July 31, 25,000 shares were issued at a cost basis of \$0.4005 per share for payment of July services.

On May 10, 2013, the Company entered into a subscription agreement with various accredited investors pursuant to which the investors purchased 2,575,000 shares of the Company's common stock at a cost basis of \$0.20 per share, for a purchase price of \$515,000, together with common stock purchase warrants to acquire 1,287,500 shares of common stock at \$0.40 per share for a period of three years.

On May 30, 2013, the Company entered into a subscription agreement with various accredited investors pursuant to which the investors purchased 250,000 shares of the Company's common stock at a cost basis of \$0.20 per share, for a purchase price of \$50,000, together with common stock purchase warrants to acquire 125,000 shares of common stock at \$0.40 per share for a period of three years.

On May 10, 2013, 18,764 shares of the Company's common stock were issued upon the exercise of 21,126 stock options and proceeds of \$1,161.

On May 10, 2013 the Company settled outstanding invoices for consulting services totaling \$126,000 by issuing 500,000 shares of common stock.

On June 5, 2013, 200,000 shares of common stock were issued for consulting services valued at \$54,800 related to introducing the Company to prospective investors. Additionally, on June 20, 2013, 100,000 shares of common stock were issued for consulting services valued at \$41,000 related to introducing the Company to investors.

On June 28, 2013, the Company settled outstanding invoices for legal services totaling \$15,000 by issuing 40,594 shares of common stock at a cost basis of \$0.3695 per share.

On June 28, 2013, the Company entered into a subscription agreement with various accredited investors pursuant to which the investors purchased 158,125 shares of the Company's common stock at a cost basis of \$0.32 per share, for a purchase price of \$50,600, together with common stock purchase warrants to acquire 79,063 shares of common stock at \$0.64 per share for a period of three years.

On July 1, 2013, the Company settled outstanding invoices for legal services totaling \$10,000 by issuing 27,062 shares of common stock at a cost basis of \$0.3695 per share.

TABLE OF CONTENTS

On August 15, 2013, Julio C. Rodriguez was named the Chief Financial Officer of the Company. Pursuant to the terms of the Employment Agreement, Mr. Rodriguez shall receive an annual salary of \$150,000. As additional compensation Mr. Rodriguez was granted options to acquire 300,000 shares of common stock at an exercise price of \$0.40 per share for a period of five years. Mr. Rodriguez is a finance executive with over 30 years experience in financial and operational leadership roles within various industries including the automotive industry.

On October 24, 2013 Raymond J. Chess was appointed as a director of AMP Holding Inc. Mr. Chess entered into a letter of agreement with the Company to receive an annual fee of \$40,000 and options to purchase 500,000 shares of the Company at \$0.26 per share over a five year period, vesting at 100,000 immediately and 40,000 every six months thereafter for a total of 500,000 shares. Mr. Chess has past experience with General Motors Co. (GM) where he had responsibility for global management of GM's crossover market segment and commercial truck segment.

On December 11, 2013, the Company entered into a Promissory Note with JMJ Financial in the principal amount up to \$335,000 of which only \$80,000 was funded. On March 7, 2014, the Company paid the outstanding balance owed under the Note and, as a result, has no further obligations to JMJ under the Note.

On March 18, 2014, the Company entered into a Subscription Agreement with Joseph T. Lukens ("Lukens"), an existing shareholder and an accredited investor, whereby Lukens agreed to acquire 30,000,000 shares of common stock and Common Stock Purchase Warrants to acquire 15,000,000 shares of common stock in consideration of \$3,000,000.

On April 22, 2014, Company Common Stock of 564,814 shares at a cost basis of \$0.108 was issued to 13 contractors for accounting, IT, sales and engineering work.

As of May 2014, the Company entered into subscription agreement with accredited investors ("May 2014 Investors") pursuant to which the May 2014 Investors purchased 14,280,000 shares of common stock for a purchase price of \$1,428,000, together with a common stock purchase warrants to acquire 7,140,000 shares of common stock at \$0.15 per share for a period of three years.

On May 16, 2014, the Company made a final settlement payment of \$140,000 to EASi (Parent Company Aerotek) for past engineering services that cancelled a note payable with varying monthly payments due through December, 2014, totaling \$169,753.

As of May 2014, the Company entered into conversion agreements with debt holders of the Company that were accredited investors ("May 2014 Conversion Investors") pursuant to which the May 2014 Conversion Investors converted \$1,169,300 into 11,693,000 shares of common stock together with a common stock purchase warrants to acquire 5,846,500 shares of common stock at \$0.15 per share for a period of three years.

The Company entered into Subscription Agreements with accredited investors (the "December 2014 Investors") providing for the sale by the Company to the December 2014 Investors of 14% Unsecured Convertible Promissory Notes in the aggregate amount of \$900,000 (the "December 2014 Notes"). In addition to the December 2014 Notes, the December 2014 Investors also received common stock purchase warrants (the "December 2014 Warrants") to acquire 3,214,286 shares of common stock of the Company. The December 2014 Warrants are exercisable for five years at an exercise price of \$0.14. The initial closing of \$200,000 was on November 24, 2014 and the second closing of \$700,000 was on December 8, 2014. The December 2014 Notes mature one year from their respective effective dates (the "Maturity Dates") and interest associated with the December 2014 Notes is 14% per annum, which is payable on the Maturity Dates. The December 2014 Notes are convertible into shares of common stock of the Company automatically upon the Company increasing its authorized shares of common stock to allow for full conversion of the December 2014 Notes. The December 2014 Notes and the December 2014 Warrants carry standard anti-dilution provisions. Further, for a period of six months from issuance, upon the issuance of common stock or common stock equivalents at a price lower than the conversion price or the exercise price, the conversion price in the December 2014 Notes and the exercise price in the December 2014 Warrants will be reduced to such lower price.

The offers, sales, and issuances of the securities described above were deemed to be exempt from registration under the Securities Act in reliance on Section 4(a)(2) of the Securities Act or Regulation D promulgated thereunder as transactions by an issuer not involving a public offering. The recipients of securities in each of these transactions acquired the securities for investment only and not with a view to or for sale in connection with any distribution thereof and appropriate legends were affixed to the securities issued in these transactions. Each of the recipients of securities in these transactions was an accredited or sophisticated person and had adequate access, through employment, business or other relationships, to information about us.

Item 16. Exhibits and Financial Statement Schedules

(a) Exhibits

See the Exhibit Index on the page immediately preceding the exhibits for a list of exhibits filed as part of this registration statement on Form S-1, which Exhibit Index is incorporated herein by reference.

(b) Financial Statement Schedules

Schedules have been omitted because the information required to be set forth therein is not applicable or is shown in the financial statements or notes thereto.

Item 17. Undertakings

The undersigned registrant hereby undertakes to provide to the underwriters at the closing specified in the Underwriting Agreement, certificates in such denominations and registered in such names as required by the underwriters to permit prompt delivery to each purchaser.

Insofar as indemnification for liabilities arising under the Securities Act may be permitted to directors, officers and controlling persons of the registrant pursuant to the provisions described under Item 14 above, or otherwise, the registrant has been advised that in the opinion of the Securities and Exchange Commission such indemnification is against public policy as expressed in the Securities Act and is, therefore, unenforceable. In the event that a claim for indemnification against such liabilities (other than the payment by the registrant of expenses incurred or paid by a director, officer or controlling person of the registrant in the successful defense of any action, suit or proceeding) is asserted by such director, officer or controlling person in connection with the securities being registered, the registrant will, unless in the opinion of its counsel the matter has been settled by controlling precedent, submit to a court of appropriate jurisdiction the question whether such indemnification by it is against public policy as expressed in the Securities Act and will be governed by the final adjudication of such issue.

The undersigned registrant hereby undertakes that:

- (1) For purposes of determining any liability under the Securities Act of 1933, the information omitted from the form of prospectus filed as part of this registration statement in reliance upon Rule 430A and contained in a form of prospectus filed by the registrant pursuant to Rule 424(b)(1) or (4) or 497(h) under the Securities Act shall be deemed to be part of this registration statement as of the time it was declared effective.
- (2) For the purpose of determining any liability under the Securities Act of 1933, each post-effective amendment that contains a form of prospectus shall be deemed to be a new registration statement relating to the securities offered therein, and the offering of such securities at that time shall be deemed to be the initial bona fide offering thereof.

SIGNATURES

Pursuant to the requirements of the Securities Act of 1933, as amended, the registrant has duly caused this Registration Statement on Form S-1 to be signed on its behalf by the undersigned, thereunto duly authorized in the City of Loveland, State of Ohio, on the 15th of December, 2014.

AMP HOLDING INC.

Dated: December 15, 2014

By: /s/ Stephen S. Burns
Name: Stephen S. Burns
Title: Chief Executive Officer
(Principal Executive Officer)

Dated: December 15, 2014

By: /s/ Julio C. Rodriguez
Name: Julio C. Rodriguez
Title: Chief Financial Officer
(Principal Financial and Accounting Officer)

POWER OF ATTORNEY

We, the undersigned officers and directors of AMP Holding Inc., hereby severally constitute and appoint Stephen S. Burns as our true and lawful attorney with full power to sign for us and in our names, in the capacities indicated below, the Registration Statement on Form S-1 filed herewith and any and all pre-effective and post-effective amendments to said registration statement and any subsequent registration statement filed pursuant to Rule 462(b) under the Securities Act of 1933, as amended, and to file the same with all exhibits thereto, and the other documents in connection therewith, with the Securities and Exchange Commission, and generally to do all such things in our name and behalf in our capacities as officers and directors to enable AMP Holding Inc. to comply with the provisions of the Securities Act of 1933, as amended, and all requirements of the Securities and Exchange Commission, hereby ratifying and confirming our signatures as they may be signed by our said attorneys, or any of them, to said registration statement and any and all amendments thereto.

Pursuant to the requirements of the Securities Act of 1933, as amended, this Registration Statement on Form S-1 has been signed by the following persons in the capacities and on the dates indicated below.

<u>Signature</u>	<u>Title</u>	<u>Date</u>
<u>/s/ Stephen S. Burns</u> Stephen S. Burns	Chief Executive Officer and Director (Principal Executive Officer)	December 15, 2014
<u>/s/ Julio C. Rodriguez</u> Julio C. Rodriguez	Chief Financial Officer (Principal Financial and Accounting Officer)	December 15, 2014
<u>/s/ James E. Taylor</u> James E. Taylor	Chairman of the Board of Directors	December 15, 2014
<u>/s/ Ray Chess</u> Ray Chess	Director	December 15, 2014

EXHIBIT INDEX

Exhibit No.	Description
1.1*	Form of Underwriting Agreement
3.1	Certificate of Designation for Series A Preferred Stock (1)
3.2	Certificate of Change (2)
3.3	Certificate of Correction (2)
3.4	Articles of Merger (3)
3.5	Certificate of Correction (Articles of Merger) (3)
3.6	Certificate of Amendment to the Certificate of Incorporation (4)
3.7	Certificate of Incorporation (5)
4.1	Stock Option to acquire 500,000 shares of common stock issued to James Taylor dated May 25, 2011 (6)
4.5	Common Stock Purchase Warrant to acquire 500,000 shares of common stock issued to James Taylor dated May 25, 2011 (6)
4.6	Stock Option to acquire 500,000 shares of common stock issued to Stephen Burns dated May 25, 2011 (6)
4.7	Common Stock Purchase Warrant to acquire 500,000 shares of common stock issued to Stephen Burns dated May 25, 2011 (6)
4.8	Conversion Letter Agreement by and between Stephen Burns and AMP Holding Inc. (7)
4.9	Promissory Note in the principal amount of \$232,400 dated November 20, 2012 payable to EASi and Aerotek (8)
4.10	Form of Subscription Agreement by and between AMP Holding Inc. and the January 2013 Accredited Investor (9)
4.12	Form of Warrant by and between AMP Holding Inc. and the January 2013 Accredited Investor (9)
4.13	Promissory Note dated January 29, 2013 (9)
4.14	Common Stock Purchase Warrant issued to Stephen Baksa (10)
4.15	Secured Debenture by and between Workhorse Custom Chassis, LLC and AMP Trucks Inc. dated March 13, 2013 (11)
4.16	Security Agreement by and between Workhorse Custom Chassis, LLC and AMP Trucks Inc. dated March 13, 2013 (11)
4.17	Mortgage, Security Agreement, Assignment of Rents and Fixture Filing by and between Workhorse Custom Chassis, LLC and AMP Trucks Inc. dated March 13, 2013 (11)
4.18	Form of Subscription Agreement entered by and between AMP Holding Inc. and the March 2013 Accredited Investors (11)
4.19	Form of Common Stock issued to the March 2013 Accredited Investors (11)
4.20	2014 Incentive Stock Plan (12)
4.23	Subscription Agreement by and between AMP Holding, Inc. and Joseph T. Lukens (13)
4.24	Form of Common Stock Purchase issued to Joseph T. Lukens (13)
4.25*	Specimen certificate evidencing shares of common stock

TABLE OF CONTENTS

Exhibit No.	Description
4.26	Form of Subscription Agreement entered between AMP Holding Inc. and the December 2014 Investors (20)
4.27	Form of 14% Unsecured Convertible Promissory Note issued to the December 2014 Investors (20)
4.28	Form of Common Stock Purchase Warrant issued to the December 2014 Investors (20)
5.1*	Legal Opinion of Fleming PLLC
10.1	Share Exchange Agreement dated as of December 28, 2009 by and among Advanced Mechanical Products, Inc., the shareholders of Advanced Mechanical Products, Inc. and Title Starts Online, Inc. (1)
10.2	Director Agreement by and between AMP Holding Inc., and James E. Taylor dated October 11, 2010 (14)
10.3	Employment Agreement by and between AMP Holding Inc. and Stephen S. Burns dated December 8, 2010 (15)
10.4	Letter Agreement by and between AMP Holding Inc. and Martin J. Rucidlo dated August 24, 2012 (16)
10.17	Release and Settlement Agreement by and between ESG Automotive, Inc., AMP Holding Inc. and AMP Electric Vehicles Inc. (8)
10.18	Conversion Agreement by and between AMP Holding Inc. and an accredited investor dated February 21, 2013 (9)
10.19	Asset Purchase Agreement by and between Workhorse Custom Chassis, LLC, as Seller, and AMP Trucks Inc., as Buyer dated as of March 4, 2013 (11)
10.20	Amendment No. 1 to the Asset Purchase Agreement by and between Workhorse Custom Chassis, LLC, as Seller, and AMP Trucks Inc., as Buyer dated as of March 13, 2013 (11)
10.21	Employment Agreement between AMP Holding Inc. and Julio C. Rodriguez dated August 15, 2013 (17)
10.23	Director Agreement by and between AMP Holding Inc. and Raymond Chess dated October 24, 2013 (18)
21.1	List of Subsidiaries (19)
23.1	Consent of Clark, Schaefer, Hackett & Co.
23.2*	Consent of Fleming PLLC (included in Exhibit 5.1)
24.1	Power of Attorney (included on signature page)

* To be filed by amendment.

- (1) Incorporated by reference to the Form 8-K Current Report filed with the Securities and Exchange Commission on January 4, 2010.
- (2) Incorporated by reference to the Form 8-K Current Report filed with the Securities and Exchange Commission on May 25, 2010.
- (3) Incorporated by reference to the Form 8-K Current Report filed with the Securities and Exchange Commission on May 25, 2010.
- (4) Incorporated by reference to the Form 8-K Current Report filed with the Securities and Exchange Commission on September 10, 2010.
- (5) Incorporated by referenced to the Form SB-2 Registration Statement filed with the Securities and Exchange Commission on February 4, 2008.
- (6) Incorporated by reference to the Form 8-K Current Report filed with the Securities and Exchange Commission on June 1, 2011.
- (7) Incorporated by reference to the Form 8-K Current Report filed with the Securities and Exchange Commission on July 11, 2012.
- (8) Incorporated by reference to the Form 8-K Current Report filed with the Securities and Exchange Commission on January 11, 2013.
- (9) Incorporated by reference to the Form 8-K Current Report filed with the Securities and Exchange Commission on February 5, 2013.
- (10) Incorporated by reference to the Form 8-K Current Report filed with the Securities and Exchange Commission on February 28, 2013.
- (11) Incorporated by reference to the Form 8-K Current Report filed with the Securities and Exchange Commission on March 13, 2013.
- (12) Incorporated by reference to the Form S-8 Current Report filed with the Securities and Exchange Commission on January 17, 2014.
- (13) Incorporated by reference to the Form 8-K Current Report filed with the Securities and Exchange Commission on March 19, 2014.
- (14) Incorporated by reference to the Form 8-K Current Report filed with the Securities and Exchange Commission on October 19, 2010.
- (15) Incorporated by reference to the Form 8-K Current Report filed with the Securities and Exchange Commission on December 13, 2010.
- (16) Incorporated by reference to the Form 8-K Current Report filed with the Securities and Exchange Commission on August 30, 2012.
- (17) Incorporated by reference to the Form 8-K Current Report filed with the Securities and Exchange Commission on August 16, 2013.
- (18) Incorporated by reference to the Form 8-K Current Report filed with the Securities and Exchange Commission on October 30, 2013.
- (19) Incorporated by reference to the Form 10-K Annual Report filed with the Securities and Exchange Commission on April 15, 2014.
- (20) Incorporated by reference to the Form 8-K Current Report filed with the Securities and Exchange Commission on December 11, 2014.

CONSENT OF INDEPENDENT REGISTERED PUBLIC ACCOUNTING FIRM

We consent to the incorporation by reference in this Registration Statement on Form S-1 of AMP Holding, Inc. (the “Company”) of our report dated April 15, 2014, with respect to the financial statements which appear in the Annual Report on Form 10-K of the Company for the year ended December 31, 2013, filed with the Securities and Exchange Commission, and to all references to our Firm included in this Registration Statement.

/s/ Clark, Schaefer, Hackett & Co.

Cincinnati, Ohio
December 15, 2014